

# DN3PD2

## Original Instruction Manual

Safety switchgear  
to monitor the speed of three-phase and  
single-phase motors without  
sensor

with  
Configuration-Software GO:BEYOND





# EG-Konformitätserklärung

## EC-Declaration of Conformity

### Hersteller/manufacturer

DINA Elektronik GmbH  
 Esslinger Str. 84  
 72649 Wolfschlugen  
 Germany



Wir erklären, dass folgendes Produkt allen einschlägigen Bestimmungen der EG-Richtlinien entspricht.  
 We declare that the following product complies with all relevant provisions of the EC directives.

Produkt/product	Beschreibung/description
DN3PD2	Sicherheitsschaltgerät zur sensorlosen Drehzahlüberwachung bei Drei- und Einphasen Motoren Safety switchgear unit to monitor the speed of 3-phases and single phase motors without sensor

EG-Richtlinien/EC-directives	Angewandte Normen/Applied standards
2006/42/EG EG-Maschinenrichtlinie/Machinery-Directive 2014/30/EU EMV-Richtlinie/EMC-Directive 2011/65/EU RoHS Richtlinie/RoHS-Directive	EN ISO 13849-1:2015 IEC 62061:2005 + AC:2010 + A1:2013 + A2:2015 IEC 61800-5-2:2016 IEC 61508: Parts 1-7:2010 IEC 60947-5-1:2016 EN 60204-1:2018 EN 61326-1 :2013 EN 61326-3-1:2017 GS-ET-20: 2016-10 (Zusatzanforderung)

Notifizierte Stelle/notified Body	EG Baumusterprüfbescheinigung/EC Type-Examination certificate
TÜV Rheinland Industrie Service GmbH Am Grauen Stein 51105 Köln Germany NB 0035	Reg.-Nr./No.: 01/205/5759.00/20

### Dokumentationsbeauftragter/authorised representative.

DINA Elektronik GmbH  
 Esslinger Str. 84  
 72649 Wolfschlugen  
 Germany

Wolfschlugen, 01.06.2020



Stefan Najib (Geschäftsführer/CEO)

## Content

1	Intended Use	7
1.1.	Approvals	7
1.2.	Safety parameters	7
1.3.	Ordering data	7
2	Safety regulations	8
3	Important information and validation	8
4	Function description	9
4.1.	Speed monitoring	9
4.2.	Acknowledge function	9
4.3.	Start-up monitoring	9
4.3.1.	Functional diagram with start-up monitoring	10
4.3.2.	Functional diagram without start-up monitoring	10
4.4.	Switch-off delay	11
4.5.	Switch-on delay	11
4.6.	Advanced settings	11
4.7.	Minimum switch-off time	12
4.8.	Password	12
4.9.	Validation	12
4.10.	Display	12
4.11.	Diagnosis	13
4.12.	Signal outputs	13
4.13.	USB interface	13
4.14.	Connections	14
4.15.	Block diagram	14
5	Applications	15
5.1.	Motor with frequency converter	15
5.2.	Motor with star-delta circuit	15
5.3.	Single-phase motor	15
5.4.	Servo motor	15
6	Mounting and removal	16
6.1.	Wiring notes	16
7	Configuration	17
7.1.	System requirements	17
7.2.	Installation the Configurations-Software	17
7.3.	Connection to the PC	18
7.4.	User interface	18
7.5.	Parameterization	19
7.6.	Machine data	20
7.7.	Read out the project	20
7.8.	Create a project	20
7.9.	Edit and Change password	20
7.10.	Diagnosis	21
7.11.	Validation	23

8	Errors: reporting and rectification	24
8.1.	LED-flash-codes	24
9	Example of application	25
10	Technical data	26
10.1.	Ambient conditions	26
10.2.	Input data	26
10.3.	Output data	26
10.4.	General data	26
10.5.	Connection data	27
10.6.	Relay load curve	27
11	Dimensions	27



Always read the additional applicable online documentation before working on/with the safety switchgear. Make sure you always work with the valid documentation. This is available online at <http://www.dina.de/downloads/>



Dispose of the device according to the national environmental regulations.

## Symbol and Notes:



### WARNING

This symbol indicates hazards that could lead to personal injury.



### CAUTION

This symbol warns of actions that could lead to property damage or malfunction.



Here you will find additional information or further sources of information.

## Version overview / Change history

Version	Date	valid for ID-No	Innovations / changes
0815	2020-06-16	34PD..	
0815	2021-06-09	34PD..	Limitation when using servo motors

## 1 Intended Use

DN3PD2 is a safety switchgear to monitor the speed of three-phase and single-phase motors without sensor. It detects or monitors a minimum speed, a maximum speed or a speed range.

The unit meets Cat. 4/ PL e acc. to ISO 13849-1, SIL (CL) 3 acc. to IEC 62061 and IEC 61508.

It can be used in safety current circuit according to VDE 0113 T.1

The safety switchgear is configured using the configuration software GO:BEYOND.

### 1.1. Approvals



### 1.2. Safety parameters

The unit meets Cat. 4/ PL e and SIL (CL) 3.

Utilization categories	PFH <sub>d</sub> [h]	MTTF <sub>d</sub> [a]	DC <sub>avg</sub>
6A DC1 2 cycles/h	$5,38 \times 10^{-9}$	441	99%
4A DC13 2 cycles /h	$1,33 \times 10^{-8}$	198	99%
6A AC1 2 cycles /h	$1,87 \times 10^{-8}$	153	99%
5A AC15 2 cycles /h	$1,87 \times 10^{-8}$	153	99%

### 1.3. Ordering data

	Description	Type	ID-No.:
Speed monitoring, sensorless	0-1200Hz, 2 contact outputs, USB interface	DN3PD2	34PD01
Speed monitoring, sensorless with coast down monitoring	0-1200Hz, 2 contact outputs, USB interface	DN3PD2	34PD02

## 2 Safety regulations

- The device may only be installed and commissioned by an electrician or trained persons who are familiar with these operating instructions and the applicable regulations regarding work safety and accident prevention.
- Observe the VDE, EN and local regulations, particularly with respect to the protective measures.
- Failure to observe the regulations may result in death, severe bodily injury or extensive property damage.
- For emergency-stop applications, either the integrated function for restart interlock must be used or automatic re-starting of the machine must be prevented by means of a higher-level control.
- During transport, storage and operation, adhere to the conditions specified in EN 60068-2-1, 2-2!
- Unauthorized modifications shall render any warranty null and void. Dangers may thereby arise that could result in severe injuries or even death.
- Install the device in a control cabinet with a protection class of at least IP54! Dust and moisture may otherwise result in impaired functions. Installation in a control cabinet is mandatory.
- Ensure adequate protection circuits at output contacts for capacitive and inductive loads!
- The device is to be installed taking into account the distances required per DIN EN 50274, VDE 0660-514.
- During operation, switching devices carry dangerous voltage. Do not remove protective covers.
- Replace the device after the first malfunction.
- Properly dispose of the device at the end of its service life.
- If these regulations are not adhered to or in the event of improper use, DINA Elektronik GmbH accepts absolutely no liability for the resulting property damages or personal injury.
- Save this product information!

## 3 Important information and validation

- The product described here was developed to perform safety-related functions as part of a complete system.
- The complete system consists of sensors, evaluation and message units as well as concepts for safe shutdowns.
- It is the responsibility of the manufacturer of a system or machine to ensure the proper overall function.
- The manufacturer of the system is required to test and to document the effectiveness of the implemented safety concept within the complete system.  
In this case, it must be checked whether the release contacts open when exceeding or falling below the thresholds.
- This verification is to be performed after every modification to the safety concept or to safety parameters.
- DINA Elektronik is not in the position to guarantee the properties of a complete system that was not designed by DINA.
- DINA Elektronik GmbH also accepts no liability for recommendations that are given or implied by the following description.
- No new guarantee, warranty or liability claims that extend beyond DINA's general delivery conditions can be derived on the basis of the following description.
- To avoid EMC disturbances, the physical environmental and operating conditions at the installation location of the product must comply with section EMC of DIN EN 60204-1.
- When using contact outputs, the safety function must be requested once a day at PL e and once a year at PL d according to IEC 61800-5-2.
- Observe the general technical data at the end of this operating manual.



## 4 Function description

The two-channel evaluation unit of the safety switchgear module measures the frequency of the effective rotating field of the motor at the measuring terminals L1, L2, L3.

If the parameterized switching threshold frequencies are exceeded or undershot ( $f_{min}$  and  $f_{max}$ ), or an internal or external fault exists, the enabling current paths 13/14, 23/24 open immediately. The device is in safe switching state.

The device has a standard USB connection. The configuration software enables a parameterization and online monitoring.

After applying the operating voltage (24 V DC) to terminals A1 and A2, the safety relay will operate a self-test. The safety relay is in safe condition for the duration of the self-test. All enable current paths are open.

After a successful self-test, the device is ready for operation. The LED OK lights up green.

### 4.1. Speed monitoring

The parameters  $f_{max}$  (maximum frequency) and  $f_{min}$  (minimum frequency) define the speed limits of the motor. The limit frequencies  $f_{max}$  and  $f_{min}$  are calculated from the speed  $n$  and the number of pole pairs:

$$f [\text{Hz}] = (n [\text{U/min}] / 60) \times \text{number of pole pairs}$$

Example:  $5000 \text{ rev/min} \times 3 (\text{number of pole pairs}) / 60 = 250 \text{ Hz}$

Asynchronous motors have a load-dependent slip between the motor speed and the rotating field frequency. This must be observed by the configuration of the switching threshold ( $f_{min}$  and  $f_{max}$ ).



#### CAUTION

Note that the method of frequency measurement does not recognize a mechanically blocked motor or an overloaded motor!

The following monitoring functions are possible:

- Monitoring only at maximum speed
- Monitoring of a speed range with startup monitoring
- Monitoring of a speed range without startup monitoring

$f_{min}$ : minimum frequency

If  $f_{min}$  is undershot, the output contacts (13-14 / 23-24) switch off.

They switch on again after the acknowledgment via the acknowledgment input Q.

Depending on the acknowledgment mode, the switch-on-conditions differ. Please note the chapter "Startup monitoring". If  $f_{min} = 0$  there is no monitoring to a minimum speed. The output contacts remain closed at standstill.

$f_{max}$ : maximum frequency

If  $f_{max}$  is exceeded, the output contacts (13-14 / 23-24) switch off.

They switch on again after the acknowledgment via the acknowledgment input Q, if  $f_{max}$  (minus hysteresis) is undershot.



#### CAUTION

Note that a coasting motor is detected either as a standstill (if  $f_{min} = 0$ , no switch-off) or underrun (if  $f_{min} > 0$ , switch-off).

### 4.2. Acknowledge function

The acknowledgment function allows the module to be reset to operational readiness after a shutdown due to under- or overspeed. The reset takes place via the input Q at the module, if none of the mentioned states is present.

Automatic or manual acknowledgment is possible. With automatic acknowledgment, the Q input must always be connected to 24 V DC.

A manual acknowledgment takes place after a falling signal edge at the input Q ( $t_Q \geq 200 \text{ ms}$  and  $\leq 10 \text{ s}$ ).

### 4.3. Start-up monitoring

The startup monitoring time  $t_A$  is a time limit within which the actual speed must be greater than  $f_{min}$ . If the minimum speed is not reached during this time, the enable current path opens again.

The start-up monitoring time is parameterized (0 s to 60 s). It is not retriggerable, it cannot be restarted while it is running.

The start-up monitoring time starts

- In case of manual acknowledgment: with the falling edge of the acknowledge signal

- In case of automatic acknowledgement: if the actual speed is  $> 1\text{Hz}$

In the acknowledgment mode without startup monitoring (os), the outputs only switch on within the permitted range.

#### 4.3.1. Functional diagram with start-up monitoring

Automatic acknowledgement ( $f_{min}$ must be at least $1,1\text{Hz}$ !)		Manual acknowledgement	
1	Start-up monitoring time starts if $f > 1\text{Hz}$	1	Start-up monitoring time starts with the falling edge of the acknowledgement signal.
2	Start-up monitoring time is expired. Enabling current path remains closed because $f > f_{min}$ .	2	Start-up monitoring time is expired. Enabling current path remains closed because $f > f_{min}$ .
3	Enabling current path opens because $f < f_{min}$	3	Enabling current path opens because $f < f_{min}$ .
4	Enabling current path closes, if $f < 0,5\text{Hz}$ .	4	Start-up monitoring time starts with the falling edge of the acknowledgement signal.
5	Start-up monitoring time starts if $f > 1\text{Hz}$ .	5	Start-up monitoring time is expired. Enabling current path opens because $f < f_{min}$ .
6	Start-up monitoring time is expired. Enabling current path opens because $f < f_{min}$ .	6	Start-up monitoring time starts again.
7	The setpoint speed was reached outside of the minimum switch-off time. Enabling current path closes.	7	Start-up monitoring time is expired. Enabling current path remains closed.
8	The setpoint speed was reached within the minimum switch-off time. Enabling current path closes after $0.5\text{s}$ .	8	Enabling current path closes because $f_{min} < f < f_{max}$

#### 4.3.2. Functional diagram without start-up monitoring

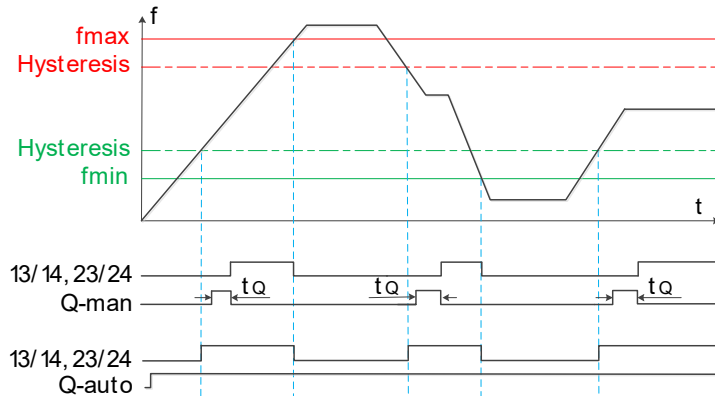

#### 4.4. Switch-off delay

Optionally, you can set a switch-off delay  $t_v$  from 0s to 2s for the enable current path. The switch-off delay time starts if a speed limit is reached. During this time, the enable contacts remain closed and the "SPEED" LED flashes. When the switch-off delay time is expired, the enable current path opens.

If the speed reaches the target range during the switch-off delay time, the contacts remain closed and the switch-off delay time is reset.



**CAUTION**

Note that changing the switch-off delay affects the reaction time of the safety function!



The switch-off delay time is not started when the shutdown occurs due to an internal or external fault.

#### 4.5. Switch-on delay

Optionally, you can set a switch-on delay  $t_E$  from 0s to 10s for the enable current path. The switch-on delay time starts, if the frequency is in range and the acknowledgement is done. During this time, the enable contacts remain open and the "SPEED" LED flashes.

When the switch-on delay time is expired, the enable current path closes.

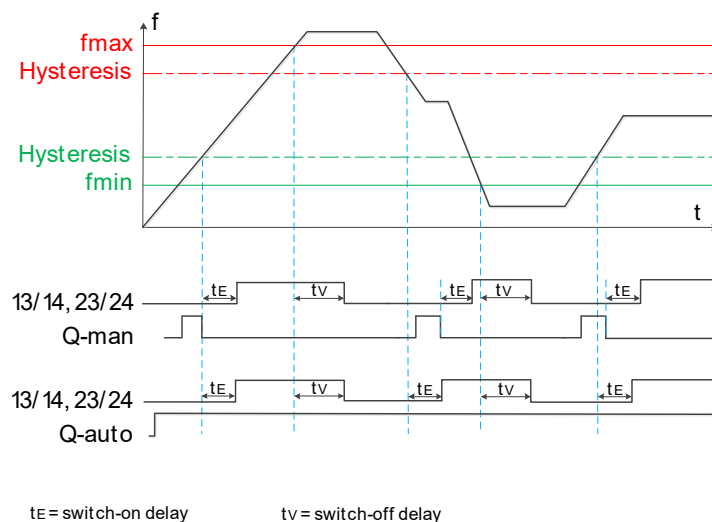

If you have also selected the "Start-up monitoring" function, the outputs only switch on after the switch-on delay time has expired. Only then is the start-up monitoring active.

#### 4.6. Advanced settings

Application dependent disturbances (e.g., vibrations or frequency overshoots) can adversely affect the measurement process. This can lead to unintentional shutdowns. To ensure availability in the case of faulty applications, you can adjust the parameters

- Number of measuring cycles
- Measurement sensitivity

##### Number of measuring cycles

In the settings "measuring accuracy" you set the number of measuring cycles to detect the movement. The parameter determines with how many measurements the measured value is formed before it is switched off.

This multiple measurement has no influence on the switch-on behavior. Switching on takes place after one measuring cycle.

Default setting: 3 measuring cycles at frequencies > 30Hz

Maximum number of measuring cycles: 4



**CAUTION**

The set factor is multiplied by the measuring time of the system and influences the reaction time of the safety relay.

Few measuring cycles = short reaction time due to fast measuring value formation, but more prone to external disturbances  
 One measuring cycle = fastest reaction time  
 Many measuring cycles = long system reaction time but robust measurement

You can change the number of measuring cycles in the configuration software. You also define from which frequency this number should be valid.

Below this frequency, a single measurement is always used.

**Sensitivity**

Change these parameters only after consultation with the DINA Elektronik GmbH service.

**4.7. Minimum switch-off time**

The minimum switch-off time  $t_{min}$  is the time that the enable current path is at least open after triggering before it switches on again. It is 0.5s.

**4.8. Password**

The transfer of the parameters and the validation function can be password protected. The password can contain a maximum of 8 characters.

**4.9. Validation**

To validate the safety function, a validation tool is available in the configuration software.

With this function, the limit values  $f_{max}$  and  $f_{min}$  are reduced or increased by 10%, 20% or 30%, thereby forcing a switch-off.

The validation requires the entry of the device password.



Note that validation displays the actual frequency, not the actual speed.

The relation actual frequency to speed (taking into account the number of poles and the gear factor) may have to be additionally validated.

**4.10. Display**

The safety switchgear indicates its operational readiness and the status of the enabling current path by the two-color LEDs "OK" and "SPEED". See table 4-1.

The red flashing LED "OK" indicates an error.

The green flashing LED "SPEED" indicates the expiry of a time constant.

LED OK	LED SPEED	Flash-code	13/14, 23/24	Status	
green	green	-	ON	acknowledged	in range
green	OFF	-	OFF	not acknowledged	out of range
green	flashing green	<b>2</b>	ON	acknowledged, start-up monitoring active	out of range
green	flashing green	<b>3</b>	ON	acknowledged, off delay active	out of range
green	flashing green	<b>4</b>	OFF	acknowledged, on delay active	in range
green	OFF	-	OFF	not acknowledged	in range
flashing red	OFF	<b>1</b>	OFF	error	See error table
red	red	-	OFF	device defect	

table 4-1

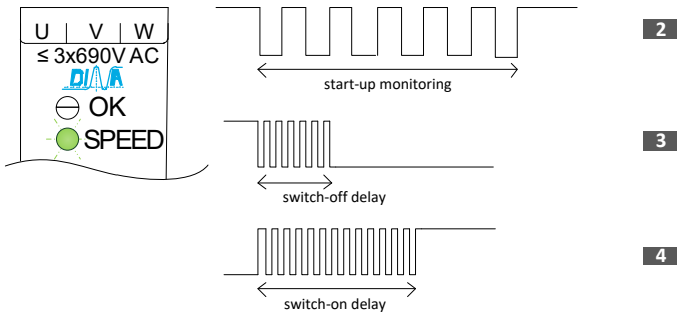
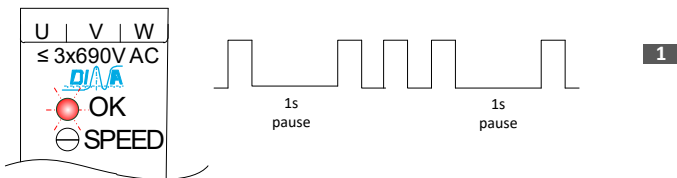

#### 4.11. Diagnosis

In conjunction with the configuration software, diagnostics offers the following functions:

- Reading out values from the safety switchgear during operation
- Reading out data which are relevant for switch-off

#### 4.12. Signal outputs

You can use the signal outputs O1 and O2 to control e.c. a non-safety PLC or signal units.

The message outputs have the following properties:

- digital
- potential-bound
- short circuit and overload protection
- not safety-related

The output O1 indicates the state of the enabling current path.

The output O2 indicates the operational readiness. This switches off in case of an error.

#### 4.13. USB interface

Via the USB connection you connect the safety s to the PC (standard USB 2.0). You need the PC connection for the following actions:

- Transfer the configuration data
- Read out the configuration to open it in the configuration software as a project and edit it if necessary.
- Diagnosis
- Validation

## 4.14. Connections



U, V, W	Measuring inputs are to be connected directly to the motor, without switching contacts between
A1	Power supply +24V DC
A2	Power supply 0V
Q	Acknowledgment input can be parameterized, manually or automatically
O1, O2	Digital positive switching semiconductor outputs for the transmission of switching states to a higher-level control for diagnostic tasks.
13-14/23-24	Enabling contacts (2 NO-contacts). These switch off immediately if the parameterized speeds are undershot or exceeded or internal or external errors. 13/14, 23/24 are to be used in such a way that the intended safety function, e.g. emergency stop is executed.
USB Port	Mini-USB for connection at PC
OK-LED	operational readiness
SPEED-LED	state of the enabling current path

## 4.15. Block diagram

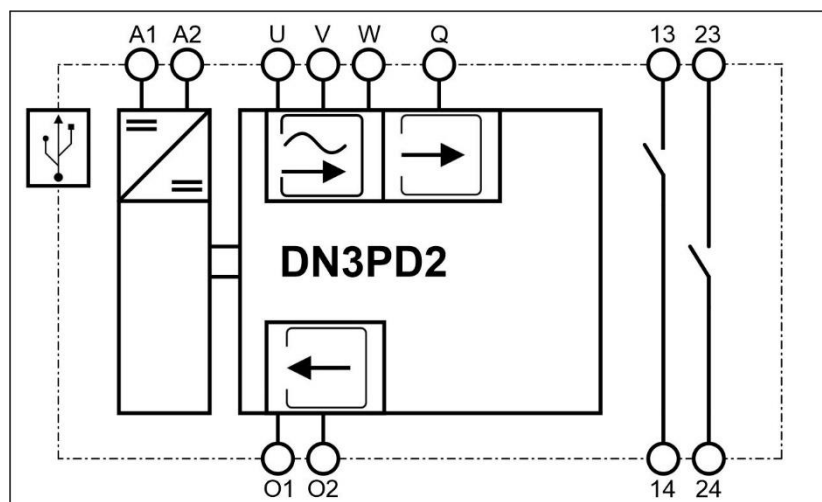

## 5 Applications

### 5.1. Motor with frequency converter

The operation on electric power drive systems with adjustable speed is possible. (Frequency converter)



**CAUTION**

Please note, that the DN3PD2 is not suitable for use on thyristor inverters.

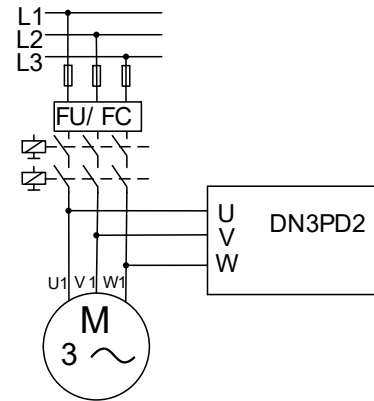

### 5.2. Motor with star-delta circuit

Operation on motors with star-delta connection or pole changeover is possible. For pole-changing motors, please note that DN3PD2 detects the frequency and not the speed!  
The measuring inputs U and W are bridged and directly connected to W1 on the motor.  
The measuring input V is directly connected to W2 on the motor.

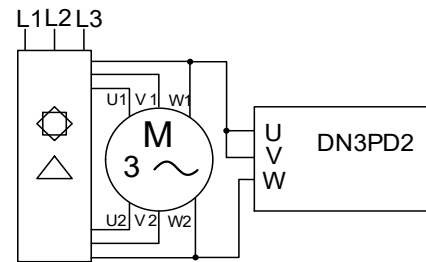

### 5.3. Single-phase motor

Operation on a single-phase motor is possible.  
The measuring inputs U and W are bridged and directly connected to U1 on the motor.  
The measuring input V is directly connected to U2 on the motor.

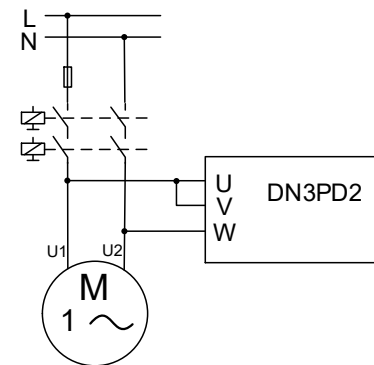

### 5.4. Servo motor

**WARNING**

Applications with servomotors are possible to a limit extent.  
The following points must be observed:

- Operation must be limited to a maximum of 480 V AC.
- The measurement sensitivity should be set to mode 4.
- In the measurement sensitivity modes 1 to 3 there is a risk of an undetected wire break at terminal W and a potentially dangerous detection of a standstill when the motor is running. For this reason, in applications with measuring sensitivity 1 to 3, the behavior with the motor running and wire break at terminal W should be checked.
- At frequencies below 2.5 Hz and a wire break at terminal W, it is possible that standstill is detected.



## 6 Mounting and removal

- Mount the safety relay on a 35 mm DIN rail according to EN 60715.
- Maintain the required distances according to DIN EN 50274, VDE 0660-514.
- Avoid strong magnetic fields near the installation. (Magnetic field strength  $<30 \text{ A/m}$ ). These can disturb the device.
- For removal, release the locking foot with the help of a screwdriver and lift the safety switch off the mounting rail.

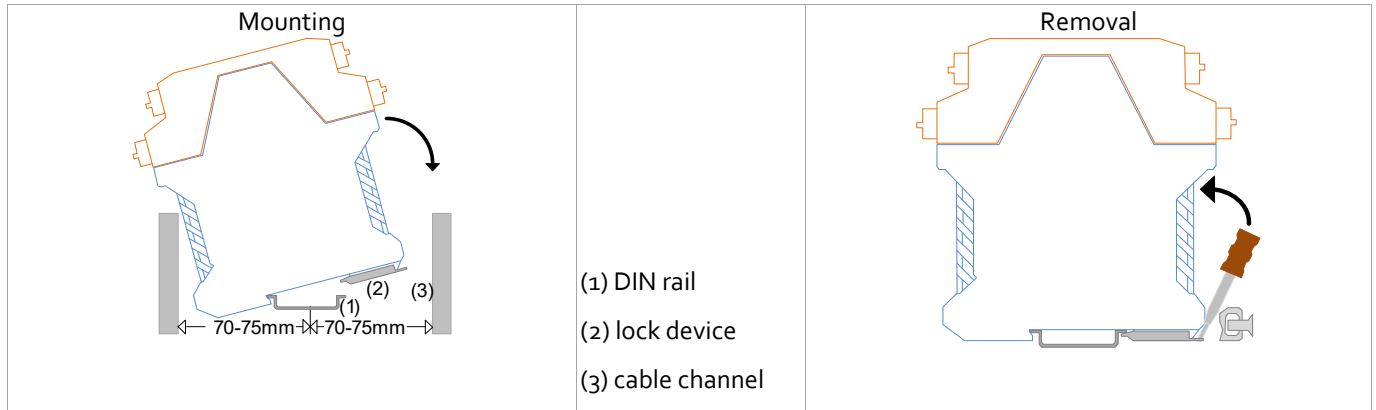

### 6.1. Wiring notes

- Use copper wires approved up to  $60^{\circ}\text{C}/75^{\circ}\text{C}$ .
- For of wire end sleeve is recommended.
- Loads connected to the measuring wires are not allowed.
- The laying of the measuring wires must prevent a cross or short circuit. Installation in a cable channel is necessary.
- Observe the regulations according to EN 60204-1.
- To prevent contact welding, insert an effective suppressor parallel to the load.
- Observe the arrangement of overcurrent protection devices.
- Overvoltage  $> 32\text{V DC}$  destroy the device. Only use power supplies that generate a maximum of  $32\text{V}$  in the event of a fault.



## 7 Configuration

The configuration of the DN3PD2 safety switchgear is made via the configuration software GO:BEYOND.  
The parameterization of the DN3PD2 is described in the following chapters.



### WARNING: Danger through incorrectly set parameters

Incorrectly set parameters for motion monitoring can lead to dangerous machine or system states.

- Make sure that the parameters entered or selected in the software correspond to the connected hardware.
- Carry out a function test after parameterization and after every change in the parameterization as part of the validation.



Assistance during validation and commissioning can be a separate measuring device or the diagnostic function (display of actual and limit values) in conjunction with the validation function in the configuration software. The diagnostic function is not safety-related.

### 7.1. System requirements

The configuration software is compatible with the following operating systems

- MS Windows 8
- MS Windows 10

Hard disk space min. 1 GB

Main memory min. 2 GB

Resolution 1920 x 1080 px

Scaling 100%

Interface USB

### 7.2. Installation the Configurations-Software

The configuration software can be found in the download area of the article at [dina.de/downloads/software](http://dina.de/downloads/software).  
Always work with the latest version of the software.

Installation of the software:

1. Download the software.
2. Start the installation.
3. Follow the instructions of the installation wizard.
4. Choose the language about "Settings" in the start screen.

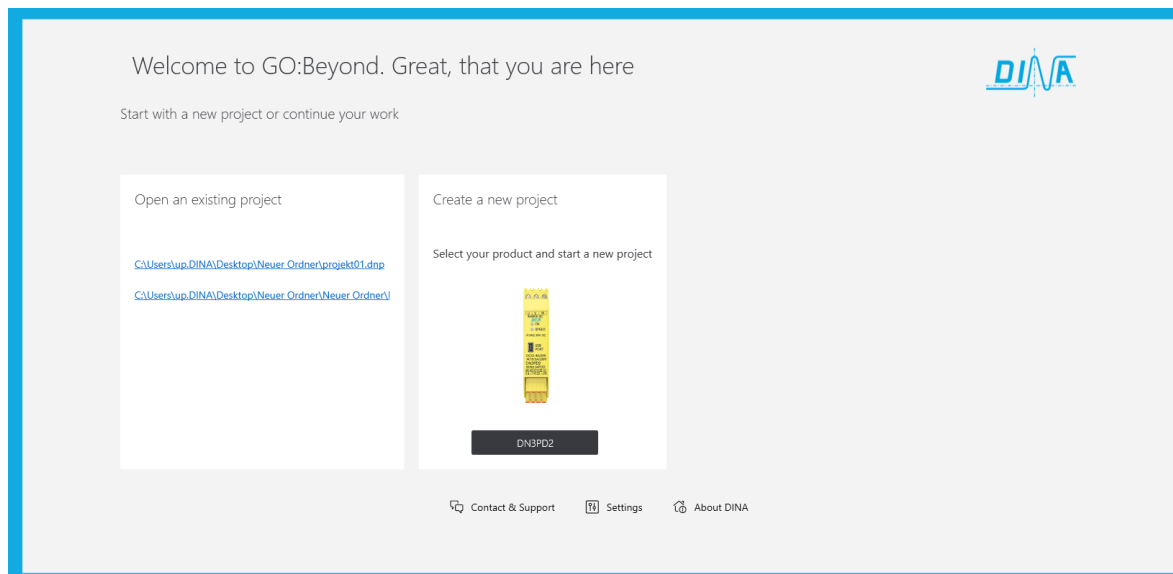

### 7.3. Connection to the PC

Communication between the safety switchgear and the configuration software takes place via the USB interface. Connect the safety relay to the PC using a suitable connection cable. The interface is suitable for standard USB cables.

### 7.4. User interface

The configuration software has the following user interface.

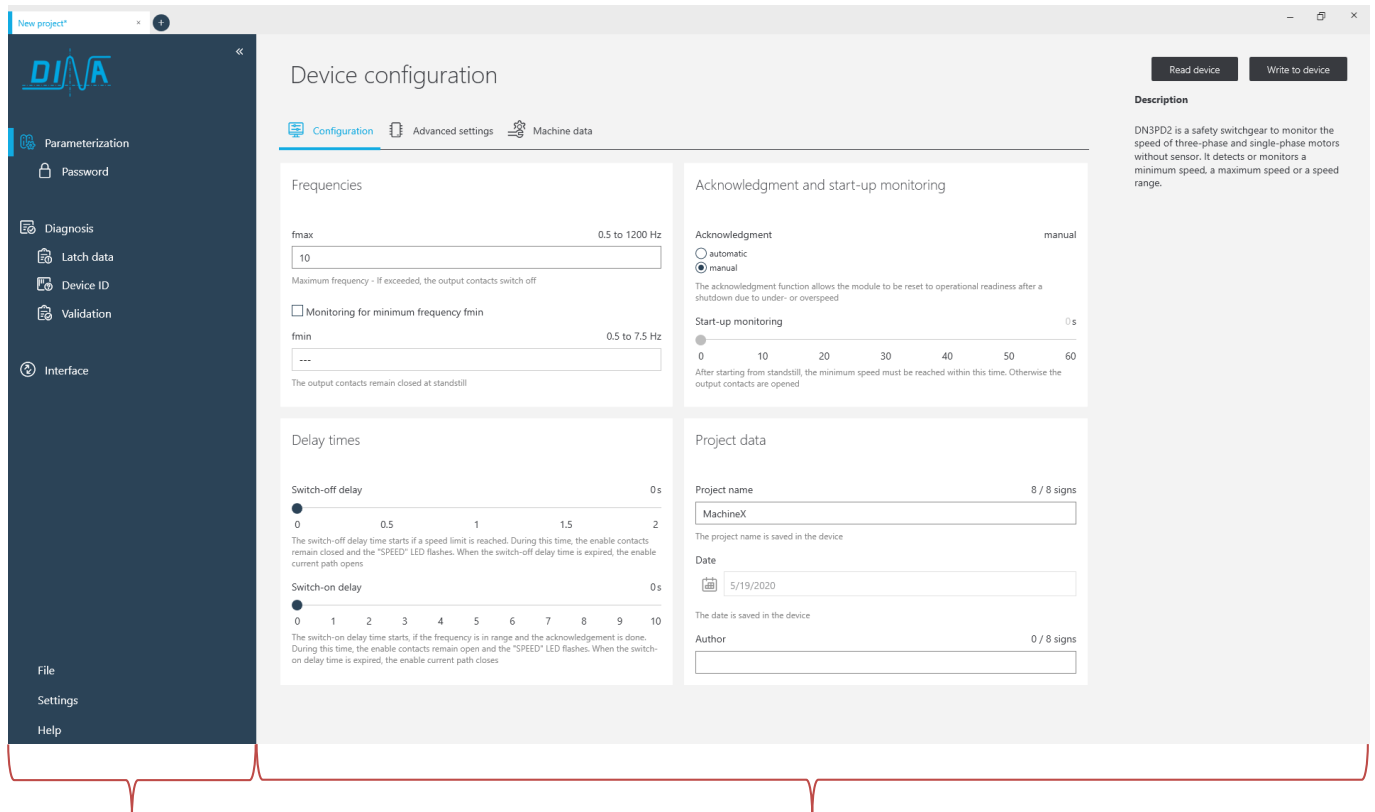

Navigationsbereich

Editor- und Aktionsbereich

#### Navigation area

In the navigation area you can select the following areas:

- Parameterization      edit parameters, password management
- Diagnostics            display of online values, error messages, switch-off-relevant data, device ID, validation
- Interface                selection of the interface
- File                        new creation / saving / opening / printing / closing a project
- Settings                 display of the working directory
- Help                        help-menu

#### Edit- and Action area

This area offers the following functions:

- Edit parameters
- Read out the parameter from the switch gear to the configuration-software
- Transmit the parameter from the configuration-software to the switch gear
- Help

## 7.5. Parameterization

You can make the following settings on the configuration software

Parameter	Range	Note
COM-Port		
Password	maximum 8 signs	
fmax *)	0.5 - 1200 Hz	
fmin *)	0.5 - 1200 Hz	Minimum speed monitoring can be deselected.
Acknowledgment	- manual - automatic	Automatic acknowledgment with start-up monitoring: fmin ≥ 1.1 Hz
Start-up monitoring	0-60s	o ≠ only range-monitoring
Switch-off delay	0-25	
Switch-on delay	0-10s	
Project name	maximum 8 signs	absolutely necessary
Author		Is not transferred to the device.
Date	mm.dd.yy	
<b>Advanced settings</b>		
<b>Measurement accuracy</b>		
Number of measuring cycles	1-4	
Frequency threshold	16 steps	
Measurement sensitivity	mode 1-4	
<b>Machine data</b>		
Axis type	Linear axis, spindle, rotary axis	
Number of pole pairs	1-99	
Ratio	0.01-99999	
Radius	1-9999	
Pitch	0.001-9999	
Max. speed		Depending on the machine data and the permitted maximum frequency.
Min. speed		

\*)

- To determine the switching thresholds, the number of pole pairs must be taken into account:  
 $f \text{ [Hz]} = (n \text{ [U/min]} / 60) \times \text{number of pole pairs}$   
 Example:  $5000 \text{ rev/min} \times 3 \text{ (number of pole pairs)} / 60 = 250\text{Hz}$
- Asynchronous motors have a load-dependent slip between the motor speed and the rotating field frequency. This must be taken into account when parameterizing the threshold frequencies (fmin and fmax).

## 7.6. Machine data

The "Machine data" calculation tool can be used to determine  $f_{min}$  and  $f_{max}$ .

Enter the machine-specific data and the tool calculates the associated frequencies. The machine data can be saved in the device. Check the checkbox "Take over machine data". Then it is no longer possible to enter the frequencies directly in the "Parameterization" menu.

## 7.7. Read out the project

You can read out the parameterization saved on the safety relay.

No password is required for reading out.

- Start the configuration software
- Open the "Interface" menu item and select the COM port.
- Open the "Parameterization" menu item.
- Click the "Read out device" button.

## 7.8. Create a project

- Start the configuration software.
- Open the "Interface" menu item and select the COM port.
- Open the "Parameterization" menu item.
- Edit the parameter.
- Transmit the project to the device with the button „save on device“.
- There is always a password prompt. If no password is saved, confirm the query with "ok".
- Confirm the settings
- Save the project

## 7.9. Edit and Change password

Protect your safety relay against unauthorized access with a device password.

- Open the menu item "Parameterization password"
- Enter the current password. If no password is assigned, the field can remain empty.
- Edit a new password and confirm it.
- Click the button "save on device".

The password is now stored in the device and must be specified when transferring a new project or when validation.

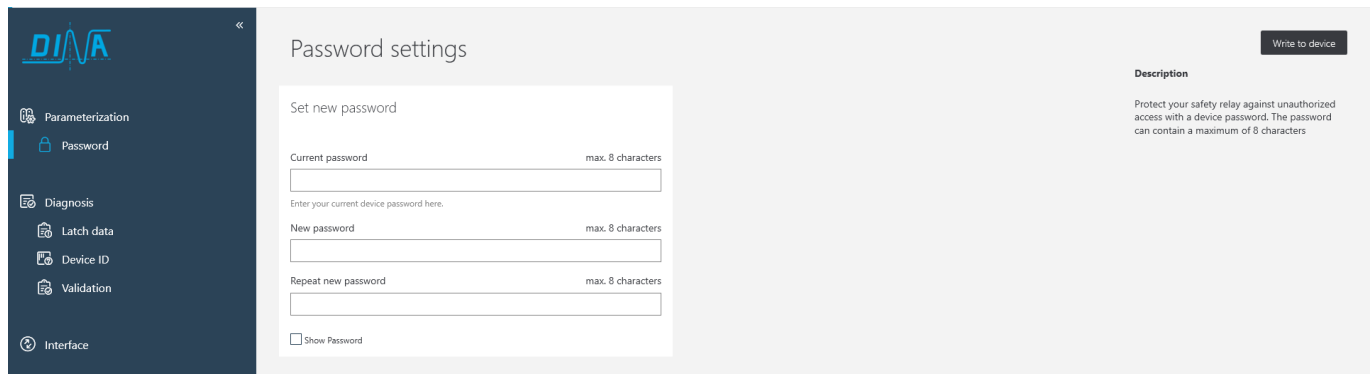

## 7.10. Diagnosis

The diagnosis offers the following functions:

1	<b>Diagnosis start / stop</b>	Start or stop the diagnosis
2	Movement/time diagram	For visual representation of the movement: blue line: actual frequency red lines: fmin and fmax
3	Status display of the input and output	13/14, 23/24: Status of the enabling current path O1: Status the output O1 O2: Status the output O2 Q: Status of the input Q
4	Help and error list	Help texts and occurred errors
5	Latch Data	Read out switch-off relevant data - Actual frequency - States of the outputs/input - advanced mode for service
6	Device ID	Hardware and Firmware information
7	Validation	See chapter „Validation“



DIANA

Parameterization  
Password  
Diagnosis  
Latch data  
Device ID  
Validation  
Interface

### Latch data

Read Device

**Description**  
After a shutdown, the switch-off-relevant data is saved in the device and can be read out. The data remains saved until it is switched off again

**Measurement**

Latch frequency master Hz  
140.73  
Actual frequency measured at the switch-off

Latch frequency slave Hz  
140.8  
Actual frequency measured at the switch-off

**Limits**

fmax Hz  
400

fmin Hz  
150.01

**States**  Advanced view

- O1
- O2
- Relay (13/14 23/24)
- Acknowledgement

**5**

DIANA

Parameterization  
Password  
Diagnosis  
Latch data  
Device ID  
Validation  
Interface

### Device ID

Read Device

**Description**  
Read out switch-off relevant data

**Hardware information**

Serial number  
DN-000295527

ID-number  
34PD01

Hardware-version  
V0082

**Firmware information**

Firmware-version  
V15.0

Date of the firmware  
1/10/2020

**6**

## 7.11. Validation

- Select the validation step
- If the device is password-protected, you will be asked to enter a valid password.

The states are recorded and can be printed out as a protocol.  
The validation level is automatically reset after 10s.

- Press the “Stop Validation” button to stop recording

The screenshot shows the 'Validation' screen in the DINA software. On the left is a dark sidebar with navigation options: Parameterization, Password, Diagnosis, Latch data, Device ID, Validation, Interface, File, Settings, and Help. The main area is titled 'Validation' and contains two panels: 'Set validation levels manually' with buttons for 0%, 10%, 20%, and 30%, and 'Automatic validation' with an 'auto. Start' button. Below these is a 'Diagnosis' section with a graph showing frequency (Hz) on the y-axis (0 to 600) and time on the x-axis (16:56:08 to 16:56:36). A blue line represents the actual frequency, which is 527.2 Hz. Red dashed lines represent the validation limits (fmin: 150.01 Hz, fmax: 600 Hz). Below the graph is a 'Status of inputs/outputs' section with a graph showing the status of inputs/outputs (0 or 1) over time.

Alternatively, you can use the “auto. Start “. The validation levels are run through step by step and reset again. The automatic validation stops automatically.

This screenshot is similar to the previous one but shows the 'auto. Start' button selected in the 'Automatic validation' section. The 'Diagnosis' graph shows the actual frequency (blue line) at 0 Hz, which is below the fmin limit of 150.01 Hz. The red dashed lines represent the validation limits (fmin: 150.01 Hz, fmax: 600 Hz). The 'Status of inputs/outputs' graph shows the status of inputs/outputs (0 or 1) over time.

## 8 Errors: reporting and rectification

The safety switchgear shows diagnosed errors that lead to the safe state of the device, as follows:

- Flash-codes of the LED „OK“ on the device.
- Error message in the software

### 8.1. LED-flash-codes

The safety relay displays error messages using LED flashing codes.

The blink code is repeated continuously with a pause of 1 s.

The meaning of the individual LED blink codes can be found in **Fehler! Verweisquelle konnte nicht gefunden werden.**

Example:

3 x flash / 1 s break / 3 x flash / 1 s break ...

That means error no. 3.

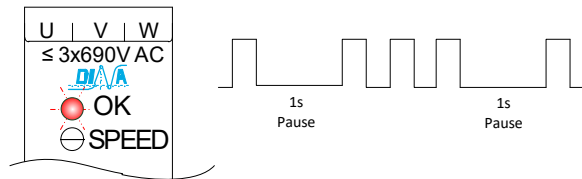

Error-no.	LED-flash-code	Meaning / diagnostic information from the software	Remedy
1	1 x flash	incorrect power supply	Check power supply UB = 20.5V-26,5V DC
2	2 x flash	transmission error parameter	Check <ul style="list-style-type: none"> <li>• interface</li> <li>• connection cable</li> <li>• Have the parameters been confirmed before transfer?</li> </ul>
3	3 x flash	incorrect acknowledge signal at input Q	Check the wiring at input Q for cross or short circuits. <b>For manual acknowledgment:</b> Check whether the start signal is within the time range of min. 200ms to max. 10s.
4	4 x flash	open-circuit on U, V, W	Check the wiring at the measuring inputs for <ul style="list-style-type: none"> <li>• short circuit</li> <li>• cross-connection</li> <li>• wire break</li> </ul>
5	5 x flash	transmission error password	The password was not confirmed. Transfer the password again.
6	6 x flash	Relay error	Send the device to DINA Elektronik for testing.
7	7 x flash	single-channel error The signals at the measuring inputs are different	Check the wiring at the measuring inputs for <ul style="list-style-type: none"> <li>• short circuit</li> <li>• cross-connection</li> <li>• wire break</li> </ul>
8	8 x flash	Frequency > 1500Hz	Check the frequency at the measuring inputs
9	9 x flash	internal error	Send the device to DINA Elektronik for testing.
10	10 x flash	internal error	Send the device to DINA Elektronik for testing.

Table 8-1



## 9 Example of application

Output contacts connected in parallel

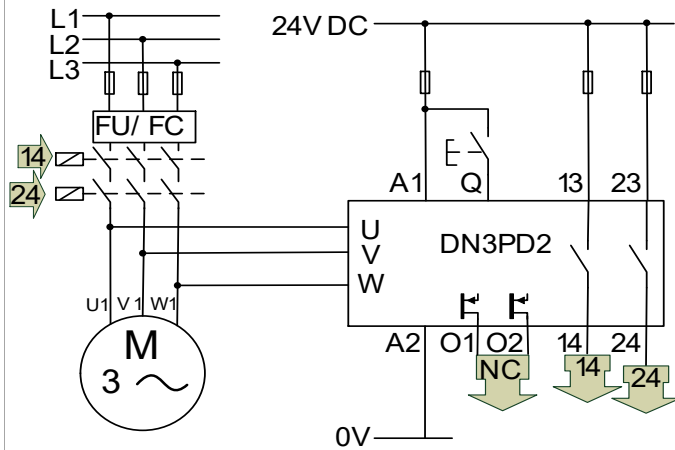

Output contacts connected in series

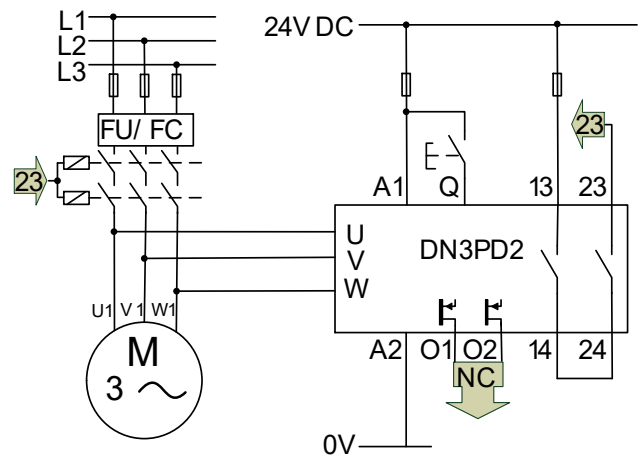

## 10 Technical data

10.1. Ambient conditions		
Ambient temperature (operation)	-20 to +55°C	
Ambient temperature (storage)	-40 to +85°C	
Maximum altitude	< 2000m above sea level	
Shock	15g	
Vibration	10–150Hz, 1g	
10.2. Input data		
Operating voltage UB	24V DC -15 % / +10 %, reverse protection	
Current draw at 24V DC	typ. 80mA	
Current draw at U, V, W	0,35mA at 690V AC	
Input voltage at U, V, W	90 to 690V AC	
Max. frequency at U, V, W	1200Hz	
Minimum-PWM	2kHz	
Measurement uncertainty	1%	
Switching hysteresis	10%	
Power consumption at A1/ A2	typ. 1,9W	
Status display	2 x LED 2-color	
Protection wiring	Overvoltage/ inverse polarity protection	
Acknowledgment input Q	24V digital	
10.3. Output data		
Relay outputs: enabling current path		
Contact type	2 enabling NO-contacts	
Contact material	AgSnO <sub>2</sub>	
Operating voltage	24V DC / 230V AC	
Minimum switching current	3 mA/ 24V DC	
Maximum switching current	6A / 24V DC/ 230V AC	
Short-circuit strength	1000A SCPD 6A gL/gG	
Mechanical life	10 <sup>7</sup> switching cycles	
Switch-off time	Number of measuring cycles x (period ( <i>reciprocal value of the set frequency</i> ) + max. 2ms cycle time) + max 10ms relay switch-on time	
Output fuse	6 A gL/gG	
B10d values acc. to DIN EN 61810-2-1, 01.2012	AC15: 5A/230V AC, >2x10 <sup>5</sup> , AC1: 6A/230V AC, >2x10 <sup>5</sup>	DC13: 4A/24V DC, >3x10 <sup>5</sup> DC1: 6A/ 24V DC, >7x10 <sup>6</sup> switching cycles
Total current 13-14 and 23-24	with parallel connection: 6A	with serial connection: 3A
Signal outputs		
Number of outputs	2 (non-safety, digital outputs O1, O2)	
Current	≤ 100mA, shot-circuit and overload protection	
Voltage	UB-1V	
10.4. General data		
Nominal operating mode	100 %	
Degree of protection	IP20	
Degree of protection of inst. location	closed cabinet, minimum IP54	
Mounting position	vertical or horizontal	
Air and creepage distances	DIN EN 50178	
Rated insulation voltage	400V AC	
Rated surge voltage / insulation	Basic insulation 6kV: between all current paths and housing  Safe insulation, reinforced insulation 8kV: between U, V, W and USB interface between U, V, W and A1, A2, O1, O2, Q between U, V, W and 13/14, 23/24	
Degree of pollution	2	
Overvoltage category	III	
Housing material/ Type	Polyamide PA not increased/ ME/ Fa. Phoenix Contact	
Dimensions	B x H x T/ 22,5 x 114 x 111 mm	

### 10.5. Connection data

Terminals/ Material	Push-in, pluggable/ PA		Screw, pluggable /PA
Number of positions	4	5	3
Conductor cross-section, flexible with wire end sleeve	0,25 - 2,5mm <sup>2</sup>	0,25 - 1,5mm <sup>2</sup>	0,25 - 2,5mm <sup>2</sup>
Conductor cross section AWG	24...12	24...16	24...12
Connection wire	60/75°C copper		
Tightening torque min/max			0,5Nm/0,6Nm

### 10.6. Relay load curve

Ohmic and inductive load for the enabling NO-contacts 13/14 und 23/24

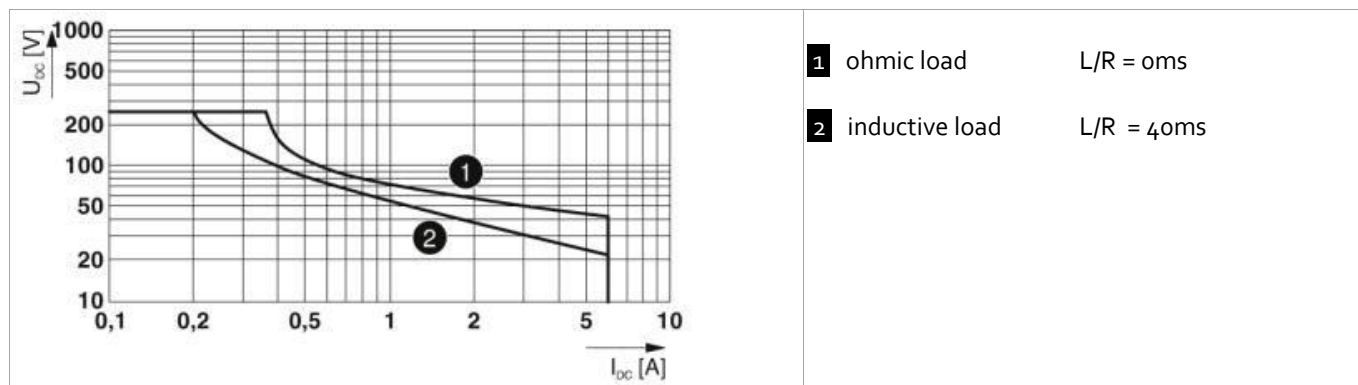

**WARNING**

Loads with high capacitive component can destroy the output contacts because the switching current is very high.

### 11 Dimensions

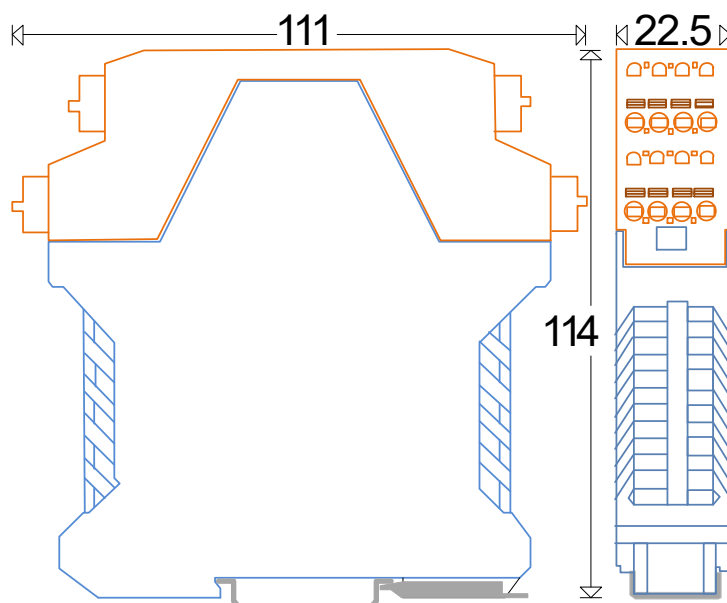



DINA Elektronik GmbH  
Esslinger Str. 84  
D72649 Wolfschlugen  
Phone +49 7022 95170  
Fax +49 7022 9517700  
info@dina.de  
www.dina.de

---