



EXME – DeviceNet Removable End Cap

- Shaft Encoder - Ø 78 mm
- Shaft: Ø 10 mm and Ø 12 mm
- DeviceNet communication protocol
- Resolution up to 30 bits
- Removable End Cap for on-site modifications
- ATEX, IECEx, EAC, certified for Mining



Electrical Specifications

Code:	Absolute - Binary
Interface:	Device Net Transceiver according to ISO 11898; up to 64 nodes galvanically isolated by opto-couplers
Resolution:	Max. 14 bit (16384) revolutions Max. 16 bit (65536) steps per rev.
Device Addressing:	Adjustable by rotary switches in the connection cap
Transmission Rate:	150 kBaud, 250 kBaud, 500 kBaud
Supply Voltage:	10 to 30 Vdc (absolute limits) According to EN 50178
Current Consumption:	Max. 230 mA with 10 Vdc Max. 100 mA with 24 Vdc
Power Consumption:	Max. 2.5 watts
Step Frequency LSB:	800 kHz
Accuracy of Division:	+/- ½ LSB (12 bit) +/- 2 LSB (16 bit)
Electrical Lifetime:	> 10 ⁵ hours
Electrical Protection:	Reverse polarity and over-voltage-peak protection
Noise Immunity:	EN61000-6-2
Emitted Interference:	EN 61000-6-4

Mechanical Specifications

Material:	Housing: Stainless Steel Cap: Stainless Steel Shaft: Stainless Steel
Weight:	Stainless Steel: ~ 3100 gr (109,35 oz)
Bearing Life:	> 1,9 x 10 ¹⁰ revolutions at rated load
Shaft Speed:	6.000 rpm (max.) IP 64 3.000 rpm (max.) IP 65/66/67/68
Starting Torque:	≤ 0,01 Nm at 25° C (no seal) ≤ 0,03 Nm at 25° C (with seal)
Rotor Mass Moment of Inertia:	42 gcm ² (5,95 x 10 ⁻⁴ oz-in-sec ²)
Shaft Loads:	Axial: 60 N (13,50 lbs) max. Radial: 80 N (17,98 lbs) max.

Environmental Specifications

Operating Temp.:	-40° to +70° C
Storage Temp.:	-40° to +70° C
Shock:	100 G / 11 ms
Vibration:	10-2000 Hz / 10 G
Bump:	10 G / 16 ms (1000 x 3 axis)
Humidity:	98 % RH without condensation
Enclosure Rating:	IP 64 / Nema 4 (approx.) IP 65 / Nema 5 (approx.) IP 66 / Nema 6 (approx.) IP 67 / Nema 6 (approx.) IP 68 (1hour/1 meter) / Nema 6P (approx.)

Certifications

ATEX:	Certificate No.: ITS09ATEX16925X I M2 Ex db I Mb, -40°C ≤ Ta ≤ +70°C
ATEX DEKRA:	Certificate No.: BVS 18 ATEX E 059 X I M2 Ex db I Mb -40°C < T.amb < +70°C
IECEX:	Certificate No.: IECEX ITS 10.0009X Ex db I Mb, -40°C ≤ Ta ≤ +70°C
IECEX TSA:	Certificate No.: IECEX TSA 11.0008X Ex db I Mb, -40°C ≤ Ta ≤ +70°C
EAC:	НАННО «ЦСВЭ» No. EAЭС RU C-DK.AA87.B.00266/19 PB Ex db I Mb X -40°C < T.amb < +70°C

Interface

Installation

The rotary encoder is connected by one, two or three cables. This depends on whether the power supply is integrated into the bus cable

or connected separately. If the power supply is integrated into the bus cable, one or two of the cable glands can be fitted with a plug. Any unused cable outlets must be closed using a suitably certified - proof blind plug. The threaded entries are M20x1,5.

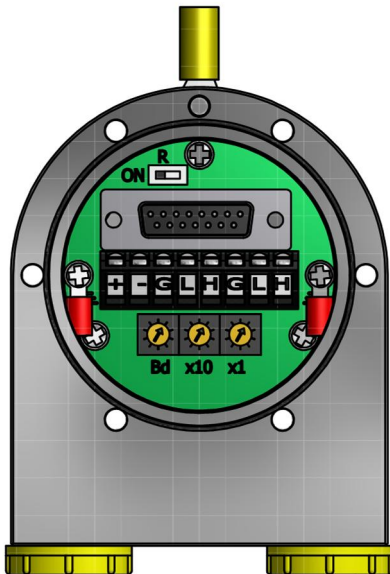

The setting of the node number is achieved by 2 turn-switches in the connection cap. Allowed addresses are between 0 and 63. Each can only be used once. **Inside the encoder, the defined address is increased by one.**

The Baud rate is set by the third rotary switch (Bd) in the cap.

The connection cap can easily be opened by removing the six screws in the cap.

The Termination Resistor is integrated into the connection cap. It must be switched on if the encoder is connected at the end or the beginning of the bus. There is separation of Bus In and Bus Out signals if the termination resistor is activated.

The EDS file is necessary for installing the encoder. The EDS file and the detailed user manual can be downloaded from our homepage: www.scancon.dk

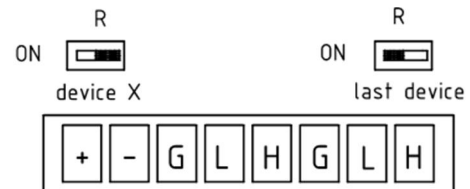

Terminal	Description
⊥	Case Ground
+	24 V Supply Voltage
-	0 V Supply Voltage
G (left)	CAN Ground (Bus in)
L (left)	CAN Low (Bus in)
H (left)	CAN High (Bus in)
G (right)	CAN Ground (Bus out)
L (right)	CAN Low (Bus out)
H (right)	CAN High (Bus out)

- **The internal earth connection** (red cable shoes) is 22-16 AWG. *La connexion à la terre interne (Borne rouge) est en 22-16 AWG.*
- **The external earth connection** (yellow cable shoe) is 12-10 AWG. *La connexion de terre externe (Borne jaune) est en 12-10 AWG.*
- **The terminal block** is intended for installation a cable with wire size:
 - solid 0,14 mm² – 2,5 mm².
 - Stranded 0,14 mm² - 1,5 mm²
 - stranded with ferrule 0,25 mm² - 1,5 mm².

The rated wire size is AWG 22-12.

- **Le bornier** est conçu pour une installation d'un câble à la taille du fil:
 - rigide de 0,14 mm² - 2,5 mm²
 - souple 0,14 mm² - 1,5 mm²
 - souple avec embout 0,25 mm² - 1,5 mm².

La taille de fil nominale est AWG 22-12.

Programmable Encoder

Parameter	Comment
Operating Parameters	This parameter determines the counting direction, in which the output code increases or decreases. As an important operating parameter the code sequence (complement) can be programmed.
Resolution per Revolution	The parameter "resolution per revolution" is used to program the desired number of steps per revolution.
Total Resolution	This parameter is used to program the desired number of measuring units over the total measuring range. This value may not exceed the total physical resolution of the absolute rotary encoder. If the encoder is used in a continuous measuring application, certain rules for the setting of this parameter must be followed. These rules are outlined in the Operating Manual.
Preset Value	The preset value is the desired position value, which should be reached at a certain physical position of the axis. The position value is set to the desired process value by the parameter preset.

Programmable Transmission Modes

Mode	Comment
Polled Mode	By remote-transmission-request telegram the connected host calls for the current process value. The absolute rotary encoder reads the current position value, calculates eventually-set parameters and sends back the obtained process value by the same identifier.
Cyclic Mode	The absolute rotary encoder transmits the actual process value event controlled by an internal timer. This is useful in reducing the bus activity.
Change of State	The absolute rotary encoder transmits the actual process value. The process value is transmitted when the position changes. This is useful in reducing the bus activity.

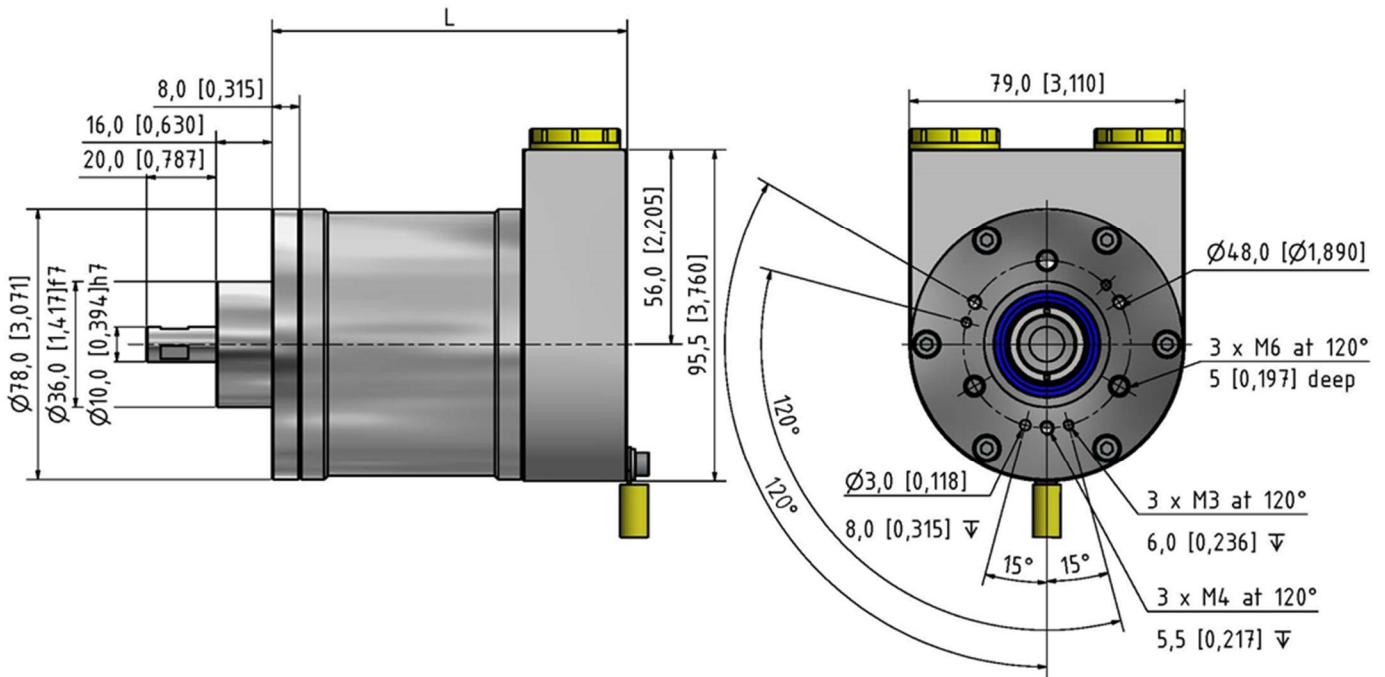
Face mounts

Face Mount C
 Clamping Flange

mm (inches)

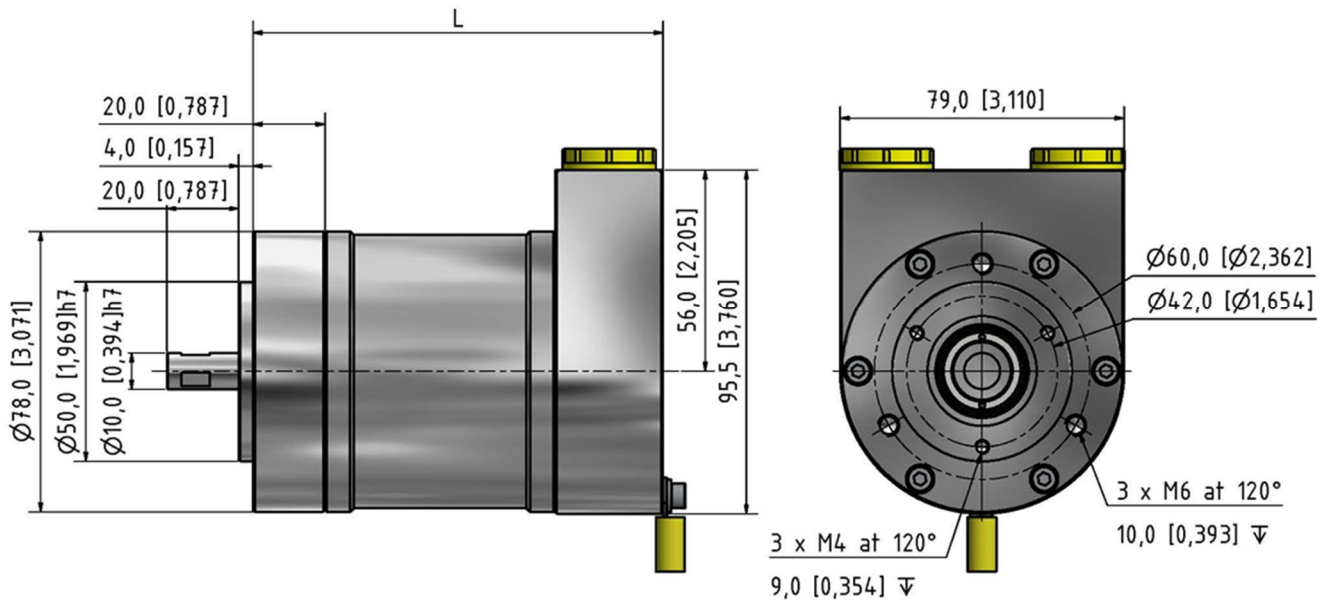

Face Mount S
 Servo Flange

mm (inches)

Plastic screw plug is for cable outlet protection during shipping and storage.
 Plug must be replaced by a suitably certified cable gland prior to use.

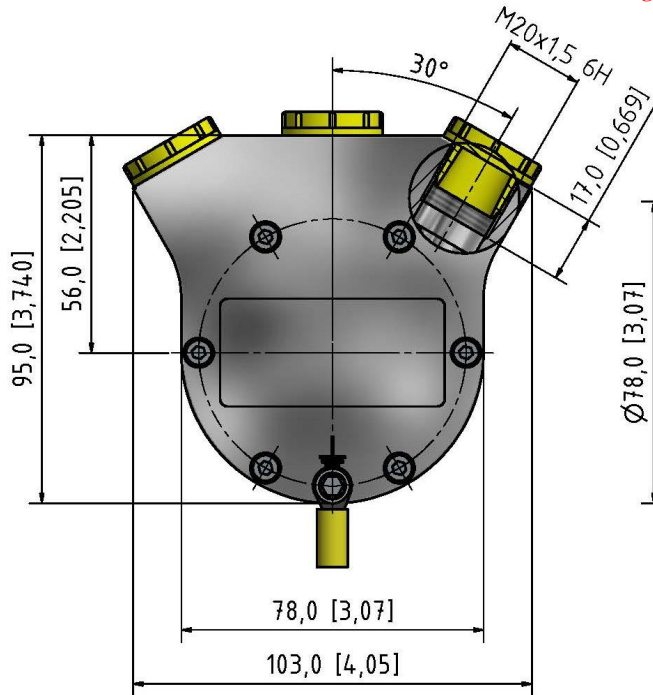

Side Triple End Cap (FE)

Removable End Cap

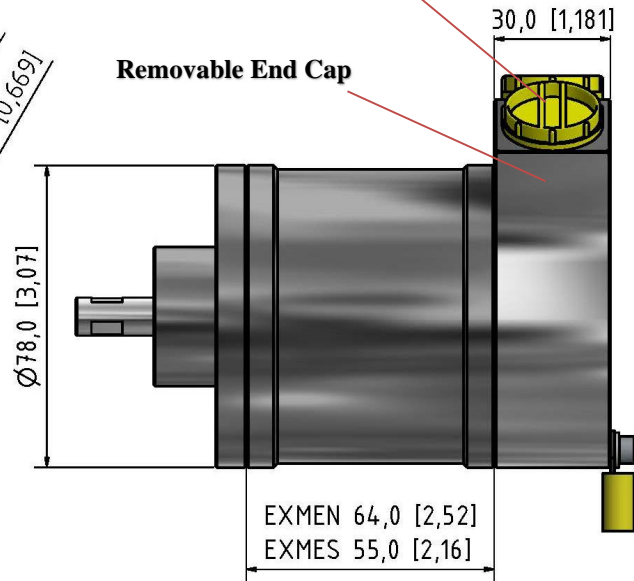

mm (inches)

Plastic screw plug is for cable outlet protection during shipping and storage.
 Plug must be replaced by a suitably certified cable gland prior to use.

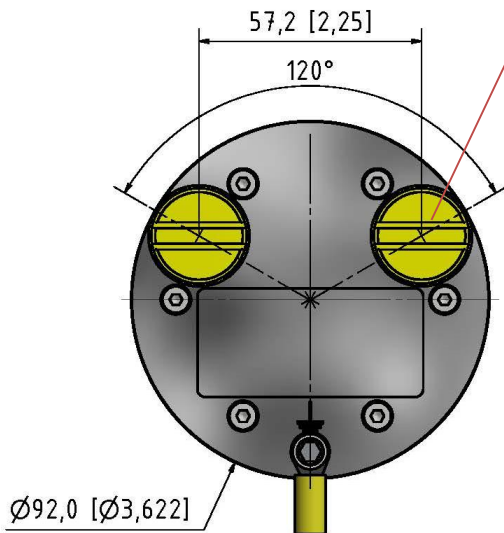

Back Round End Cap (FG)

Removable End Cap

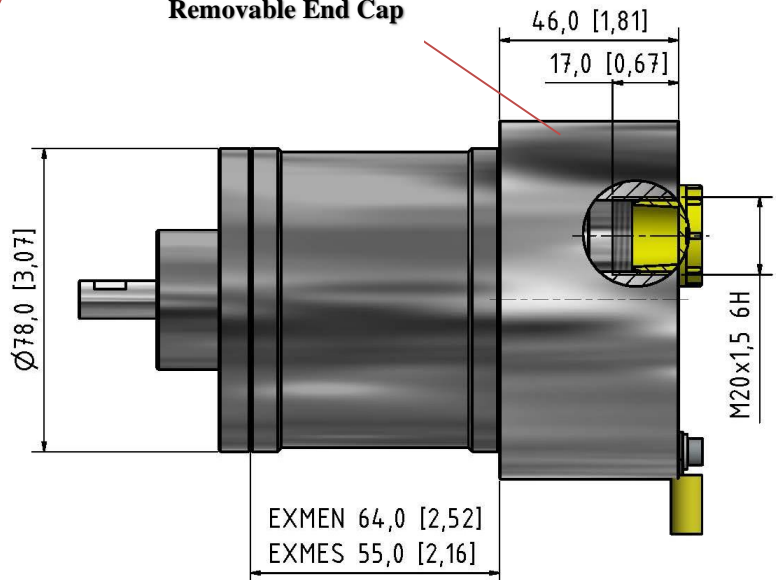

mm (inches)

Encoder Length
**Housing N (Table 1)
 (64 mm)**
Total Encoder Length

End Cap	Face Mount		
	Clamping Flange C	Servo Flange S	Square Flange Q
FZ	102 mm (4,02 in)	114 mm (4,49 in)	115,5 mm (4,55 in)
FE	102 mm (4,02 in)	114 mm (4,49 in)	115,5 mm (4,55 in)
FG	118 mm (4,65 in)	130 mm (5,12 in)	131,5 mm (5,18 in)

End Cap + Face Mount + 64 mm = Total Encoder Length

**Housing S (Table 2)
 (55 mm)**
Total Encoder Length

End Cap	Face Mount		
	Clamping Flange C	Servo Flange S	Square Flange Q
FZ	93 mm (3,66 in)	105 mm (4,29 in)	106,5 mm (4,68 in)
FE	93 mm (3,66 in)	105 mm (4,29 in)	106,5 mm (4,68 in)
FG	109 mm (4,29 in)	121 mm (4,76 in)	122,5 mm (4,82 in)

End Cap + Face Mount + 55 mm = Total Encoder Length

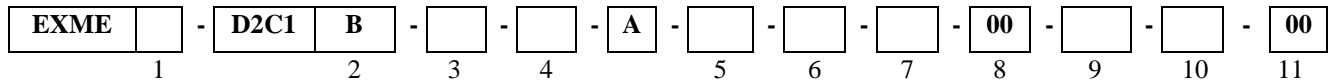
Ordering Code
Example: EXMEN – D2C1B – 12 – 13 – A – VA – 01 – 66 – 00 – FZ – C – 00

1. Housing

 64 mm length N
 55 mm length S

See Table 1 & 2

2. Interface

 Vers. D2C1/
 Code Binary B

3. Revolution

 Single Turn..... 00
 Multiturn 12 bits (4096) 12
 Multiturn 14 bits (16384)..... 14

4. Steps per revolution

 12 bits (4096) (0.09°).....12
 13 bits (8192) (0.04°).....13
 16 bits (65536) (0.005°)....16

5. Composition

 Stainless Steel* VA
 Stainless Steel** SA

 * AISI 303
 ** AISI 316

6. Shaft (diameter x length)

 10 mm x 20 mm 2 flats, 8mm Length01
 12 mm x 25 mm 2 flats, 8 mm length 02
 10 mm x 20 mm 1 flat, 15 mm length 03

7. IP Rating

 IP 64 64
 IP 65 65
 IP 66 66
 IP 67 67
 IP 68* 68

*1 meter/1 hour

8. Cable

No cable..... 00

9. Cable Outlets

 Side Standard 2 outlets FZ
 Side Triple 3 outlets..... FE
 Back Round 2 outlets..... FG

10. Flange

 Clamping flange C
 Synchro flange S
 SquareQ

11. Accessory

No accessory..... 00