

ROTAPULS

Incremental encoder

Series

ICS



- Robust & corrosion resistant housing
- For linear measurements with pinion + rack or metric wheel
- Movable shaft absorbs mounting misalignments
- Absolute version on request



ICS

ENVIRONMENTAL SPECIFICATIONS

Shock:	100 g, 6 ms
Vibrations:	10 g, 5-2000 Hz
Operating temperature range:	-25°C +85°C (-13°F +185°F)
Storage temperature range:	-25°C +85°C (-13°F +185°F) (98% R.H.without condensation)
Protection:	IP67, connector IP65

MECHANICAL SPECIFICATIONS

Dimensions:	see drawing
Shaft hollow:	∅ 12 mm
Shaft loading (axial and radial):	100 N max.
Shaft rotational speed:	6000 rpm max.
Starting torque at 20°C:	≤ 3 Ncm (typical)
Bearings life:	400 x 10 ⁶ rev. min. (10 ⁹ rev. min. with 20 N shaft loading max)
Weight:	~ 1,2 kg (42,3 oz)

ELECTRICAL SPECIFICATIONS

Resolution (PPR):	2-4-5-8-10-12-15-16-20-24-25-30-35-36-40-50-60-64-70-80 90-100-120-127-142-150-160-180-200-216-230-236-240-250 254-256-267-270-300-314-360-375-400-410-435-471-500 512-600-635-720-750-800-900-1000-1024-1068-1200-1250 1270-1400-1440-1500-1800-2000-2048-2250-2400-2500
Pulses/mm:	to be result of pinion and rack ratio
Counting frequency:	60 kHz max.
Output circuit:	NPN, PNP, Push-Pull, Line Driver, Universal circuit
Power supply:	+5V±5%, +10V +30V,+5V +30V
Consumption:	70 mA (typical)
Output current (each channel):	40 mA max.
Protection:	against inversion of polarity and short-circuit
EMC:	electro-magnetic immunity, according to EN 61000-4-2 EN 61000-4-4
Optoelectronic life:	100.000 hrs min.

MATERIALS

Housing:	anticorodal, UNI EN AW-6082
Bearings:	ABEC 5
Shaft:	stainless steel, non-magnetic - UNI EN 4305
Light source:	GaAl diodes

ACCESSORIES

E7MLS:	7 pin MIL mating connector
E10MLS:	10 pin MIL mating connector
LKM-1225:	Z40 pinion
LKM-1224:	M0,79 rack

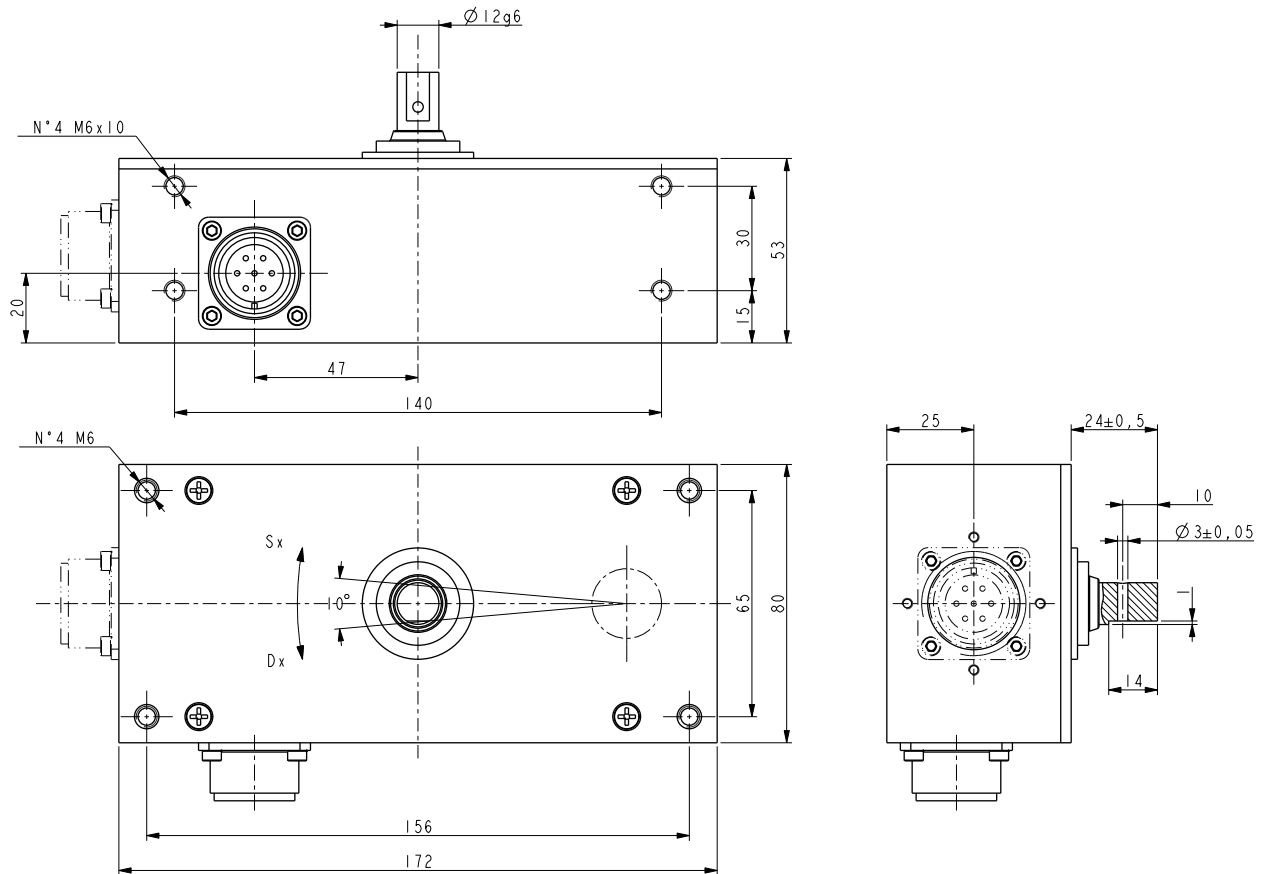

ICS

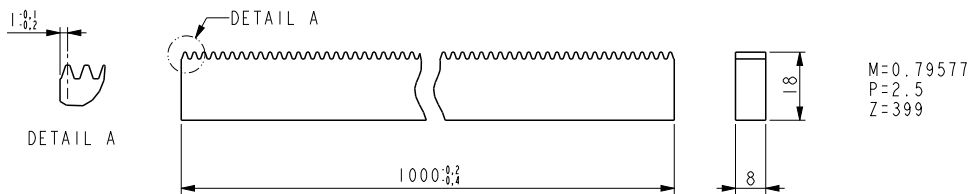

LKM-1224 (rack)

Order code

ICS	-	X	-	XXXXX	XXX	X	X	XX	X	/Sxxx
		(a)		(b)	(c)	(d)	(e)	(f)	(g)	(h)

(a) OUTPUT CIRCUITS

N = NPN o.c.
 P = PNP o.c.
 Y = Push Pull
 L = Line Driver (RS422)
 H = PP/LD universal circuit

(b) RESOLUTION (PPR)

See electrical specifications

(c) OUTPUT SIGNALS / CONNECTIONS

BND = AB, MIL 7 pin plug
 BCP = AB /AB, MIL 10 pin plug (only radial)
 ZND = AB0, MIL 7 pin plug
 ZCP = AB0 /AB0, MIL 10 pin plug (only radial)

(d) SUPPLY VOLTAGE

1 = +5V±5% (L output circuit)
 2 = +10V÷ +30V (Y output circuit)
 4 = +5V÷ +30V (H output circuit)

(e) SHAFT DIAMETER

F = 12 mm

(f) SHAFT REST POSITION

DX = right (see drawing)
 SX = left (see drawing)

(g) CONNECTION POSITION

- = axial
 R = radial (with BCP, ZCP)

(h) CUSTOM VERSION