



## POWER – SIMPLY SAVE

**3<sup>in</sup>1**

Energy management, power quality monitoring and analysis,  
residual current monitoring (RCM)

**Janitza®**

General information		Page 04
01	Janitza electronics® Company profile	04
	Communication: UMG selection schematic	14
Energy and power quality measurement products		Page 17
02	Measurement devices for DIN rail installation:	UMG 103-CBM 21   UMG 20CM 27   UMG 604-PRO 37   UMG 605-PRO 47 UMG 801 55   UMG 804 73   UMG 806 81   RCM-201-ROGO 89   RCM-202-AB 93
	Measurement devices for front panel installation:	UMG 96-S2 99   UMG 96RM 103   UMG 96RM-E 111   UMG 96-PA/UMG 96-PA-MID+ 119 UMG 96-PQ-L 131   UMG 509-PRO 139   UMG 512-PRO 147
	Mobile power quality analysers:	MRG 96RM-E RCM Flex / MRG 512-PRO PQ Flex 159
Energy management		Page 165
03	MID energy meters	165   ProData® data logger
	Field bus modules series FBM	181
Software and IT solutions		Page 185
04	Janitza software and IT solutions	185   Power Grid Monitoring Software – GridVis®
	Programming language Jasic®	201   APPs – expansion with know-how
	Multi Protocol Server (OPC UA)	217   Database server
Industrial data communication		Page 225
05	Industrial data communication	225
Current / voltage transformers and sensors		Page 243
06	Current transformers	243   Residual current transformer for RCM Monitoring
	Accessories	279
Accessories		Page 287
07	Accessories – Integration and installation aids	287
Power factor correction (PFC) and harmonics filters		Page 291
08	Prophi® power factor controller	293   PFC power capacitors
	Automatic PFC systems without reactors	307
	Automatic de-tuned PFC systems	313   Dynamic PFC systems (real time PFC)
	PFC spare parts and accessories	329
Services		Page 335
09	Services	335
Technical annex		Page 349
10	Technical annex	349
Logistics information and T&Cs		Page 433
11	Logistics information and T&Cs	433

21 27 37 55 73 81 89 99 103 119 131 139 159



UMG 103-CBM UMG 20CM & module 20GM-CT6 UMG 604-PRO/ UMG 605-PRO UMG 801 UMG 804 UMG 806 RCM 201-ROGO/ RCM 202-AB UMG 96-S2 UMG 96RM/ UMG 96RM-E UMG 96-PA/ UMG 96-PA-MID+ UMG 96-PQ-L UMG 509-PRO/ UMG 152-PRO MRG 96RM-E RCMFlex / MRG 512 PQ Flex

165 175 181



MID energy meters ProData® FBM modules

226 228 230 231 232 236 238



EasyGateway V50 GPS radio receiver Gateway MBUS-GEM PowerToStore D-SUB bus connector Power supply Smart Energy Panel

244 248 256 262 265 270 272 273 274 277 280 282



Moulded case current transformers Calibratable moulded case CTs Cable type split core current transformers Compact CT27 Flexible current transformer Differential current transformer Feedthrough residual CT Residual current transformer type A Residual current transformer type B+ Split-core current transformers SC-CT21 Voltage tap Current transformer terminal block

293 301 307 313 321



Prophi® PFC power capacitors Automatic PFC without reactors Automatic de-tuned PFC Dynamic PFC



William Thomson, Baron Kelvin known as "Lord Kelvin",  
\* 26th June 1824, † 17th December 1907

"IF YOU CAN'T MEASURE IT,  
YOU CAN'T IMPROVE IT"

"WAS MAN NICHT MESSEN KANN,  
KANN MAN NICHT VERBESSERN"

# MEASURE – VISUALISE – OPTIMISE

**TAKE THE FIRST STEP – MEASURE YOUR ENERGY DATA CONTINUOUSLY AND RELIABLY WITH JANITZA ENERGY MEASUREMENT TECHNOLOGY.**

**The advantages of qualified measurement:**

**Increased safety**

- Increase system availability
- Reduce the risk of fire

**Greater efficiency**

- Uncover potential cost savings
- Establish preconditions for tax savings
- Sustainably optimise processes
- Reduce energy costs
- Increase productivity
- Perform load curve analyses – to reduce costs through the avoidance of load peaks

**Sustainable environmental relief**

- Protect the environment through lower CO<sub>2</sub> emissions
- Enhance the company's image

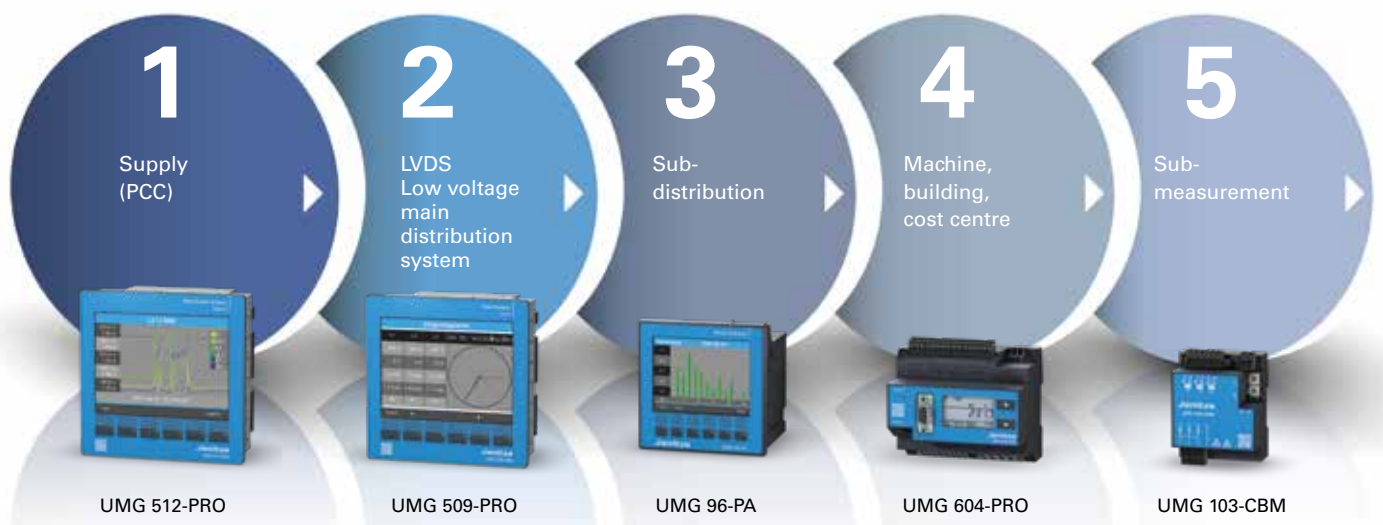
**Compliance with legal standards**

- Energy management system: In accordance with DIN EN ISO 50001
- Power quality: In order to ensure a reliable energy supply, various different standards around the world define different aspects of the "Power quality".

**MEASURE ON FIVE LEVELS**

**Measure with system**

Measure from the supply right to the sub-distribution. Measure continuously!  
Only in this way are your values transparent and traceable.



Maximum transparency with Janitza energy measurement devices – from the energy supplier to the sub-measurement.

# JANITZA

## ENERGY MEASUREMENT TECHNOLOGY



Company based  
in Lahnau.

### LOG ENERGY DATA DISPLAY ENERGY CONSUMPTION REDUCE COSTS

Nowadays, energy management is not only relevant for the environment and for society but is also a critical competitive factor. Only those who can keep a close eye on their energy consumption can reduce costs and increase energy efficiency. To ensure optimum use of the measurement devices, Janitza offers the corresponding accessories and tailored software solutions and services – an optimally tailored portfolio for efficient energy management.

## FUTURE WITH TRADITION

Made in Germany



### The company

We develop and manufacture in the Hessian city of Lahnau, between Wetzlar and Gießen. Our hardware and software products are always ahead of their time - and have been for more than half a century now. We introduce new technologies and combine existing applications to form convincing, intelligent products.

Eugen Janitza GmbH, founded in 1961, went on to produce an independent subsidiary company in 1986: Janitza electronics GmbH. Under the management of Markus Janitza. Just two years after its establishment, Janitza presented the world's first electronic reactive consumption controller with harmonic limit values and automatic step switching. Since July 2020 Rudolf Müller directs in the position of second managing director in cooperation with the owner Markus Janitza the fortune of the expanding company.



Managing director Markus Janitza (left)  
and Rudolf Müller (right)

### **Our portfolio**

Your secure, sustainable and efficient handling of electrical energy is our top priority.

The comprehensive Janitza product portfolio ranges from the current transformer and measurement device, from the communications devices and the IT environment, right through to software solutions and databases including data analyses. After formulating the technical solution, on request Janitza provides support throughout the entire product life cycle. This includes commissioning, instructing personnel, delivering regular training, as well as the maintenance and support of the systems.



# GLOBAL PROJECTS – LOCAL SUPPORT

*With reference projects spread across all continents, we cover all important market segments such as building management, energy suppliers, industry and infrastructure.*

### **Our markets**

#### **60 countries – various market segments**

With local sales partners, Janitza carries out projects around the world in the areas of energy management, power quality and residual current monitoring. In doing so, it is particularly important to us to be able to provide direct local support to the customer.

Alongside sophisticated logistics, our customers also benefit from comprehensive services, such as technical consultancy and development of customer-specific monitoring solutions, commissioning, employee training, analyses of the measurement data and regular maintenance of the systems.

**For more information visit [www.janitza.com](http://www.janitza.com)**

# ENERGY MEASUREMENT TECHNOLOGY WITH VISION

## ONE SYSTEM – THREEFOLD BENEFITS

Energy management, power quality monitoring and residual current monitoring in a single system environment. That is what the comprehensive Janitza product range stands for. The software and hardware components are optimally tailored to one another. Profit from our total competence and comprehensive services across the entire product life cycle.

Further information on our products, software solutions and services, as well as interesting practical examples, can be found on our website [www.janitza.com](http://www.janitza.com). We look forward to hearing from you!

# 3in1

MADE  
IN  
GERMANY



Janitza GridVis®  
Network visualisation software



Janitza energy measurement  
devices

### 1. Energy management (per DIN EN ISO 50001)

- Reduces CO<sub>2</sub> emissions
- Reduces energy costs
- Improves energy efficiency

### 2. Power quality monitoring

- High-availability power supply
- Reduces downtimes
- Optimises maintenance

### 3. Residual current monitoring / fault current monitoring (RCM)

- Minimum effort for DGUV V3
- Improves supply reliability
- Identifies insulation faults faster
- Improves fire protection

Energy management  
DIN EN ISO 50001

Power quality  
DIN EN 50160

Residual current monitoring  
(RCM)



# ENERGY MANAGEMENT SYSTEMS

The reduction in energy costs can be a significant competitive factor, because in many industry sectors the energy costs constitute a relevant item on the company results. In this regard, the ISO 50001 standard aims to establish the framework conditions for an operational energy management system. Energy flows must be made transparent and they must be analysed, in order to sustainably save costs and decisively reduce energy consumptions and CO<sub>2</sub> emissions. It is also possible to identify problems in the energy supply with an energy management system.

In response to these requirements, Janitza has developed the ISO 50001-certified GridVis® software. The software offers the user the tool required for establishing an efficient, manageable and consistent energy management system. In this way, measures can be developed for the improvement of the energy efficiency of processes, systems and devices with the help of the measured data provided. The effect of the implemented measures is continuously monitored by the energy monitoring system, the results are verified for example with the help of key figures (KPIs) and quantity flow diagrams (Sankey).

- Energy management systems increase the (energy) efficiency of processes, systems and devices (ISO 50001, VDE 0100-801):
- Continuous energy monitoring helps with the rapid identification of significant deviations in the power supply. Furthermore, this monitoring also supports fulfilment of the taxation and regulatory aspects (German law on renewable energy sources, peak balancing per German electricity tax law, etc.).
- Through transparent energy flows it is possible to reduce the costs, minimise maintenance outlay and identify energy-intensive consumer devices:
- The visible reduction of energy consumptions and CO<sub>2</sub> emissions makes a contribution to environmental protection:
- MID-compliant devices from Janitza can be used in combination with GridVis® software for cause-related cost centre management. MID is a measuring instruments directive of the European Parliament, which includes such requirements as manipulation security and therefore provides legal certainty.



GridVis® KPI example – key figures are an important instrument for the energy manager

# POWER QUALITY

## System assurance and highly-availability power supply

Continuous monitoring of the power quality in all technical systems per IEC 61000-2-4 is essential, in order to avoid unnecessary repair costs and production downtimes.

The voltage in the grid nowadays is far removed from the ideal sinusoidal waveform. Voltage interruptions, transients, harmonics, flickers or start-up currents: Various different "grid feedback effects" change the sinusoidal character of the currents and thus also the power quality. Impermissible electrical loading and increased thermal losses are then a daily occurrence. This can result in the equipment operating in a restricted manner or its service life being adversely affected. This risks a production failure.

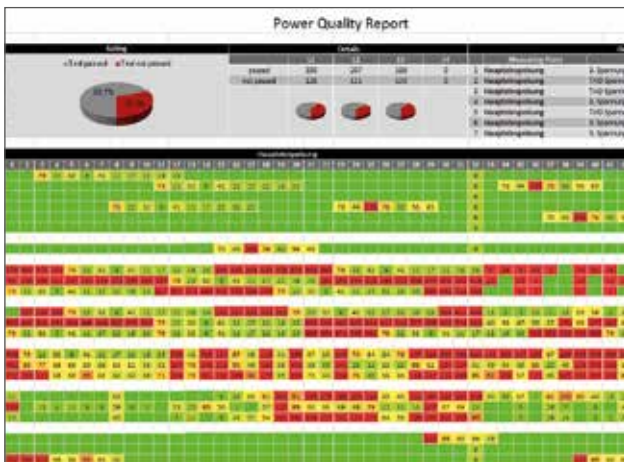
## Detect grid feedback effects promptly

Solid power quality management measures the power quality continuously, analyses the acquired data and highlights the central starting points for optimisation. In doing so, it also pursues the objective of reducing maintenance costs. For example, the class A power quality analyser UMG 512-PRO enables the power quality to be monitored in accordance

with the established standards, such as EN 50160, IEEE 519 or EN 61000-2-4. In addition, the device also measures flicker and harmonics up to the 63rd harmonic. The UMG 509-PRO also continuously monitors the power quality and provides analysis of electrical disturbances in the event of network problems. On the lower network levels, the UMG 96RM serves to record energy consumers and standard variables, as well as further basic power quality parameters.

## PQ reports with the GridVis® monitoring software

With the aid of meaningful reports, Janitza's TÜV-approved software GridVis® delivers sound and comprehensible information on the power quality. The GridVis® reporting system is the heart of the network analysis. The PQ reports provide a rapid overview of any standard and threshold value infringements that arise. Furthermore, they show whether the power quality is adequate or not within the time period in question. The traceability and tracking of the measured values is assured with the GridVis® software. Legal certainty is provided.



GridVis® PQ Heatmap

- Secure, highly-availability power supply  
Assured quality of the electrical energy through continuous monitoring and analysis.
- Avoidance of overload situations
- Avoidance of production stoppages
- Maximisation of operating times
- Ensuring product quality/stable processes  
Production-related quality assurance by monitoring the local power quality.
- Optimisation of the maintenance costs

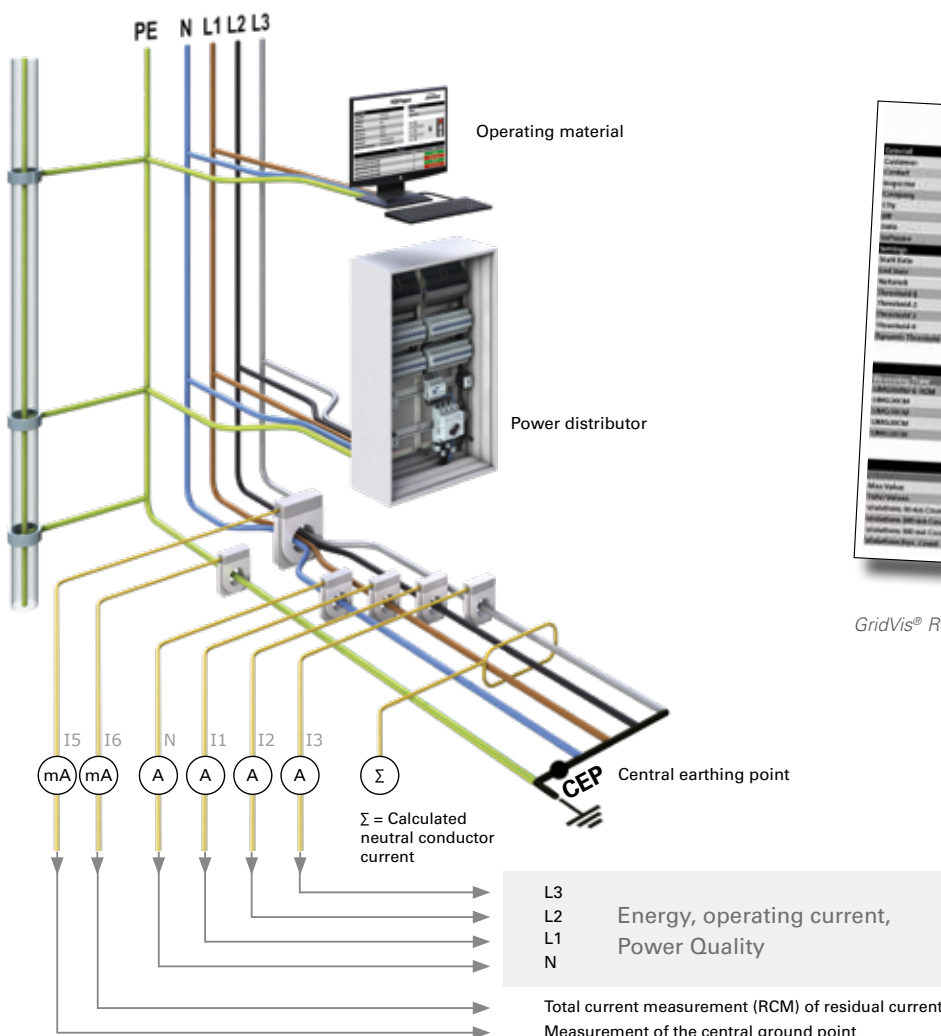
Residual current monitoring (RCM)

# RESIDUAL CURRENT MONITORING (RCM)

**Safe – modular – future-oriented**

Residual current monitoring (RCM) plays a decisive role in high-availability power supply systems. Constant measurement and early warnings can enable the rapid and direct localisation of faults and insulation problems. This applies in particular to quietly rising residual currents (e.g. triggered by an insulation fault), overly high operating currents and any other overloading of system parts and consumers. This not only protects against risks of fire but also increases the system availability. In this way, it is frequently possible to avoid costly shut-downs through residual current circuit breakers (RCD) and minimise servicing costs. With an electrical system or static operating equipment, complex insulation measurements within the framework of DGUV V3 are superfluous and this results in a significant reduction in testing outlay.

- Early alerts in the event of a possible overload
- Increased system and operational certainty
- Reduction in servicing costs
- Avoiding the risk of fire
- Significant outlay reduction with DGUV V3 testing



GridVis® RCM report

TN-S system (5-conductor network) – Basic precondition for the safe operation of IT equipment, machinery and networked systems including residual current monitoring

# STANDARDISED SPECIFICATIONS

## DIN EN 16247-1

### Energy audit

- Defines the requirements for an energy audit
- One-off acquisition/analysis of the energy consumption
- Obligation for all non SMEs since 2015

## DIN EN ISO 50001

### Energy management systems

- Specifications for systematic energy management
- Precondition for the partial release of energy-intensive companies from the German law on renewable energy sources

## DIN VDE 0100-801

### Energy efficiency in low voltage systems

- Directive for planning energy distribution, also applies for retrofits to older systems
- Prescribes the use of energy measurement technology in all energy distribution systems

## DIN VDE 0100-801

### Energy efficiency in low voltage distribution systems

- Valid and binding since December 2015
- Electrical and practical supplement to ISO 50001
- Valid for new systems and the updating of older systems
- Measurement, monitoring and control of:  
Consumptions, load management, power quality, harmonics, voltage drop, optimum load utilisation of transformers (25-50%), reactive power load
- Recording the measured values = Basis for planning expansions

## DGUV V3

### Operating equipment testing

- Insulation testing: Can be minimised with continuous documentation of the residual currents

## EN 50160

### Power quality standard for energy suppliers

- "Incoming goods inspection - current"
- Enforceable product liability standard

## EN 61000-2-4

### Power quality standard within companies

- Threshold values for the loads of electronic components, caused by grid feedback
- Key phrase: Warranty claims



WE MAKE  
ENERGY VISIBLE



# DIN RAIL MEASUREMENT DEVICE

## RESIDUAL CURRENT MONITORING DEVICES



**UMG 20CM**

- 63<sup>rd</sup> harmonic
- Modularly expandable
- Optional operating/residual current measurement
- 4 voltage measurement channels
- 20 measurement channels
- 20 LEDs for warning and alarm message



**RCM 202-AB**

- Standards compliant to IEC 62020
- Residual current analysis Type B
- Residual current detection Type B+
- Modbus interface
- LCD display



**RCM 201-ROGO**

- Measurement with Rogowski coil
- Modbus interface
- Different measuring ranges adjustable

## UNIVERSAL MEASUREMENT DEVICES



**UMG 806**

- 31<sup>st</sup> harmonic
- Modularly expandable
- Residual current measurement
- Optional Ethernet
- Display & 2 key operation
- Class 0,5S

## ENERGY ANALYZERS



**UMG 103-CBM**

- 40<sup>th</sup> harmonic
- Communication settings directly on the device
- Compact – 4 DU
- Comparator
- Consistent measurement
- Modbus interface
- Class 0,2S

## NETWORK ANALYZERS



**UMG 801**

- 127<sup>th</sup> harmonic
- Modularly expandable for current (92 channels)
- Multifunction channels: RCM, temperature, current
- Events and transients
- 1000 V CAT III
- Class 0,2S



**UMG 804**

- Modularly expandable for current (96 channels)
- Homepage
- Power Quality (THD-V & THD-I, Waveform Capture)
- Energy class 0.5



**UMG 604-PRO**

- 40<sup>th</sup> harmonic
- Homepage
- Events and transients
- Programming options (Jasic & Apps)
- Power quality analysis onboard
- 300 V CAT III
- Class 0,5S

## POWER QUALITY ANALYZERS



**UMG 605-PRO**

- 63<sup>rd</sup> harmonic
- Homepage
- Flicker measurement
- Events and transients
- Programming options (Jasic & Apps)
- Power quality analysis onboard
- EN 50160 / 61000-2-4

# FRONT PANEL INSTALLATION MEASUREMENT DEVICE



- 15<sup>th</sup> harmonic
- Cost-effective
- 2 key operation
- Modbus interface
- Class 0,5S

UMG 96-S2



- 40<sup>th</sup> harmonic
- Different interface variants
- 2 key operation
- Comparator
- Consistent measurement
- Modbus interface
- Class 0,5S

UMG 96RM Serie



- 40<sup>th</sup> harmonic
- Modularly expandable
- RCM
- MID certification
- Color graphical display & 6 key operation
- 600 V CAT III
- Ethernet interface
- Class 0,2S

UMG 96-PA Serie



- 65<sup>th</sup> harmonic
- Modularly expandable
- RCM
- Color graphical display & 6 key operation
- 600 V CAT III
- Ethernet interface
- Class 0,2S

UMG 96-PQ-L



- 40<sup>th</sup> harmonic
- RCM
- Homepage
- Events
- 300 V CAT III
- Ethernet interface
- Class 0,5S

UMG 96RM-E



- 63<sup>rd</sup> harmonic
- Residual current measurement
- Events and transients
- Programming options (Jasic & Apps)
- Power quality analysis onboard

UMG 509-PRO

## POWER QUALITY ANALYZER CLASS A



- 63<sup>rd</sup> harmonic
- Class A according to IEC 61000-4-30
- Residual current measurement
- Flicker measurement
- Events and transients
- Programming options (Jasic & Apps)
- Power quality analysis onboard
- EN 50160 / 61000-2-4

UMG 512-PRO

# 02 Energy and power quality measurement products

<b>UMG 103-CBM</b> <ul style="list-style-type: none"> <li>• Compact universal measurement device for DIN rail mounting without display</li> <li>• Communication via RS485 Modbus RTU</li> <li>• Continuous sampling of the voltage and current measurement inputs</li> </ul>	<b>Page 21</b> 
<b>UMG 20CM &amp; Modul 20CM-CT6</b> <ul style="list-style-type: none"> <li>• Operating current and residual current monitoring device (RCM – Residual Current Monitor)</li> <li>• 20 current and 3 voltage measurement channels</li> <li>• RS485 interface and Modbus protocol</li> </ul>	<b>Page 27</b> 
<b>UMG 604-PRO / UMG 605-PRO</b> <ul style="list-style-type: none"> <li>• Power analyser for DIN rail mounting with Ethernet, Profibus and integrated homepage</li> <li>• Master device for energy management systems, extensive Power Quality measurements</li> <li>• Flicker measurement in accordance with DIN EN 61000-4-15 (UMG 605-PRO)</li> </ul>	<b>Page 37</b> 
<b>UMG 801</b> <ul style="list-style-type: none"> <li>• Modular energy measurement device</li> <li>• Easy system expansion thanks to flexible scaling to up to 92 current measurement channels</li> <li>• Easy integration into a higher-level system through open communication architecture via OPC UA standard</li> </ul>	<b>Page 55</b> 
<b>UMG 804</b> <ul style="list-style-type: none"> <li>• Modular power analyzer for branch circuits</li> <li>• Branch circuit monitoring in PDUs</li> <li>• Expandable to 96 current measurement channels</li> </ul>	<b>Page 73</b> 
<b>UMG 806</b> <ul style="list-style-type: none"> <li>• Modular energy measurement device</li> <li>• Applicable in IT-, TN- and TT-networks</li> <li>• High measuring accuracy for current and voltage</li> </ul>	<b>Page 81</b> 
<b>RCM 201-ROGO &amp; RCM 202-AB</b> <ul style="list-style-type: none"> <li>• Recording, evaluating and monitoring of residual currents according to IEC 62020</li> <li>• Two CT inputs or one rogowski coil connection</li> <li>• Increase safety of electrical installations</li> </ul>	<b>Page 89</b> 
<b>UMG 96-S2</b> <ul style="list-style-type: none"> <li>• Universal measurement device for measuring and controlling electrical variables and energy consumption</li> <li>• Suitable for TN and TT networks with a 1 and 5 A transformer connection</li> <li>• Simple tariff conversion as additional building block for energy and cost transparency</li> </ul>	<b>Page 99</b> 
<b>UMG 96RM / UMG 96RM-E</b> <ul style="list-style-type: none"> <li>• Compact multifunction measurement device for energy measurement with various interfaces and protocols</li> <li>• Powerful microprocessor and high sampling rate for maximum measurement accuracy</li> <li>• Recording of energy data and load profiles for energy management systems (e.g. ISO 50001)</li> </ul>	<b>Page 103</b> 
<b>UMG 96-PA / UMG 96-PA-MID+</b> <ul style="list-style-type: none"> <li>• Modular energy measurement device</li> <li>• Four functions – one solution: Energy management, MID, Power Quality and RCM monitoring</li> <li>• Measurement of current and voltage parameters and RCM measurement</li> </ul>	<b>Page 119</b> 
<b>UMG 96-PQ-L</b> <ul style="list-style-type: none"> <li>• Modularly expandable power analyzer</li> <li>• High memory density</li> <li>• Harmonics up to the 65th</li> </ul>	<b>Page 131</b> 
<b>UMG 509-PRO / UMG 512-PRO</b> <ul style="list-style-type: none"> <li>• High-performance power quality analyser with RCM – Residual Current Monitor (UMG 509-PRO)</li> <li>• Class A power quality monitoring device certified per IEC 61000-4-30 (UMG 512-PRO)</li> <li>• Harmonics up to the 63rd</li> </ul>	<b>Page 139</b> 
<b>MRG 96RM-E RCM Flex / MRG 512-PRO PQ Flex</b> <ul style="list-style-type: none"> <li>• Mobile energy measurement devices / power quality analysers</li> <li>• Acquisition and long-term recording of load profiles as well as power quality measured values</li> <li>• Analyzing of power supplies in accordance with EN 50610 as well as internal networks per EN 61000-2-4</li> </ul>	<b>Page 159</b> 





# ENERGY AND POWER QUALITY MEASUREMENT PRODUCTS



## Chapter 02 Overview of UMG measurement devices



Type	UMG 103-CBM (UL certified)	UMG 20CM	Module 20CM-CT6	UMG 604-PRO (UL certified)		UMG 605-PRO (UL certified)	UMG 801 (UL certified)	Module 800-CT8-A (UL certified)	UMG 804	
				E	EP				AC	DC
Item number	52.28.001	14.01.625	14.01.626	52.16.202	52.16.201	52.16.227	52.31.001	52.31.201	14.02.001	14.02.009
Use in three-phase 4-conductor systems with grounded neutral conductor up to a maximum of	277 / 480 V AC	230 / 400 V AC	Only current measurement	277 / 480 V AC	277 / 480 V AC	277 / 480 V AC	347 / 600 V AC (UL) 480 / 830 V AC (IEC)	Only current measurement	480 V AC	
Use in three-phase 3-conductor systems ungrounded up to a maximum of	-	-	-	480 V AC	480 V AC	480 V AC	690 V AC	-	277 V AC	
Supply voltage	-	90 – 276 V AC; 90 – 276 V DC	-	95 – 240 V AC; 135 – 340 V DC <sup>*1</sup>	95 – 240 V AC; 135 – 340 V DC <sup>*1</sup>	95 – 240 V AC; 135 – 340 V DC <sup>*1</sup>	24 – 48 V DC, PELV	-	90 – 300 V AC <sup>*14</sup> 12 – 24 V DC <sup>*14</sup>	
Three-conductor / four-conductor (L-N, L-L)	- / •	• / •	- / •	• / •	• / •	• / •	• / •	-	• / •	
Quadrants	4	4	4	4	4	4	4	4	4	
Sampling rate 50/60 Hz, measuring points per second	5.4 kHz	20 kHz	60 kHz	20 kHz	20 kHz	20 kHz	51.2 kHz (V) / 25.6 kHz (A)	8.33 kHz	40 kHz	
National certification according to PTB-A 50.7	-	-	-	-	-	-	-	-	-	
Effective value from periods (50/60 Hz)	10 / 12	10 / 12	10 / 12	10 / 12	10 / 12	10 / 12	10 / 12	10 / 12	10 / 12	
Residual current inputs	-	20 <sup>*11</sup>	6 <sup>*11</sup>	-	-	-	4 <sup>*4</sup>	-	-	
Current measuring channels	3	20 <sup>*11</sup>	6–96 (max. 16 modules) <sup>*11</sup>	4	4	4	8	8–80	max. 96	
Thermistor input	-	-	-	1	1	1	4 <sup>*4</sup>	-	-	
Harmonics V / A	1. – 40.	1. – 63.	1. – 63.	1. – 40.	1. – 63.	1. – 63.	1. – 127 / 1. – 63.	1., 3., 5. ... 15.	-	
Distortion factor THD-U / THD-I in %	•	•	only THD-I	•	•	•	•	only THD-I	•	
Unbalance	-	-	-	•	•	•	•	-	-	
Short-term flicker / long-term flicker	-	-	-	-	-	-	-	-	-	
Transients	-	-	-	> 50 µs	> 50 µs	> 50 µs	-	-	-	
Short-term interruptions	-	-	-	•	•	•	-	-	-	
Accuracy V; A	0.2%; 0.2%	1%; 1%	-; ; 0.5%	0.2%; 0.25%	0.2%; 0.25%	0.2%; 0.25%	0.2%; 0.2%	0.5%	0.5% <sup>*15</sup>	
Class A per EN 61000-4-30	-	-	-	-	-	-	-	-	-	
Active energy class	0.5S (.../5 A)	1	2	0.5S (.../5 A)	0.5S (.../5 A)	0.5S (.../5 A)	0.2S (.../5 A)	0.5S (.../5 A)	0.5 <sup>*16</sup>	
Digital inputs	-	-	-	2	2	2	4	-	2	
Digital / pulse output	-	2	-	2	2	2	4	-	2	
Analogue output	-	-	-	-	-	-	1	-	-	
Memory min. / max. values	•	•	•	•	•	•	•	*9	-	
Memory size	4 MB	768 KB	Only via UMG 20CM	128 MB	128 MB	128 MB	4 GB	-	-	
Clock	•	•	Only via UMG 20CM	•	•	•	•	*9	-	
Integrated logic	Comparator	Current threshold values per channel	Current threshold values per channel	Jasic® (7 Prg.)	Jasic® (7 Prg.)	Jasic® (7 Prg.)	-	-	-	
Webserver / e-mail	-	-	-	• / •	• / •	• / •	-	-	• / -	
APPs: Measured value monitor, EN 50160 & IEC 61000-2-4 Watchdog	-	-	-	•	•	•	-	-	-	
Fault recorder function	-	-	-	•	•	•	-	-	-	
Peak load optimisation	-	-	-	• <sup>*2</sup>	• <sup>*2</sup>	• <sup>*2</sup>	-	-	-	
Software for energy management and network analysis	GridVis®-Essential	GridVis®-Essential	GridVis®-Essential	GridVis®-Essential	GridVis®-Essential	GridVis®-Essential	GridVis®-Essential	GridVis®-Essential	GridVis®-Essential	
<b>Interfaces</b>										
RS232	-	-	-	•	•	•	-	-	-	
RS485	•	•	Only via UMG 20CM	•	•	•	•	*9	•	
USB	-	-	-	-	-	-	•	-	•	
D-Sup-9-connector (Profibus)	-	-	-	-	•	•	-	-	-	
M-Bus	-	-	-	-	-	-	-	-	-	
Ethernet	-	-	-	•	•	•	2	*9	•	
<b>Protocols</b>										
Modbus RTU	•	•	Only via UMG 20CM	•	•	•	•	*9	•	
Modbus gateway	-	-	-	•	•	•	• <sup>*10</sup>	-	•	
Profibus DP V0	-	-	-	-	•	•	-	-	-	
Modbus TCP/IP, Modbus RTU over Ethernet	-	-	-	•	•	•	Modbus TCP/IP	*9	•   -	
SNMP	-	-	-	•	•	•	-	-	•	
OPC UA	-	-	-	-	-	-	•	*9	-	
BACnet IP	-	-	-	• <sup>*2</sup>	• <sup>*2</sup>	• <sup>*2</sup>	-	-	only Advanced	
Profinet	-	-	-	-	-	-	-	-	-	

• : included  
- : not included

\*1 Other voltages are also optionally available

\*2 Option

\*3 Combination possibilities for the inputs and outputs:  
a) 5 Digital outputs  
b) 2 digital outputs and 3 digital inputs

\*4 Combined function: optionally analog / thermistor / residual current input

\*5 2 pulse outputs

\*6 SNMP only for internal Profinet communication

\*7 With module + 1 current measuring channel



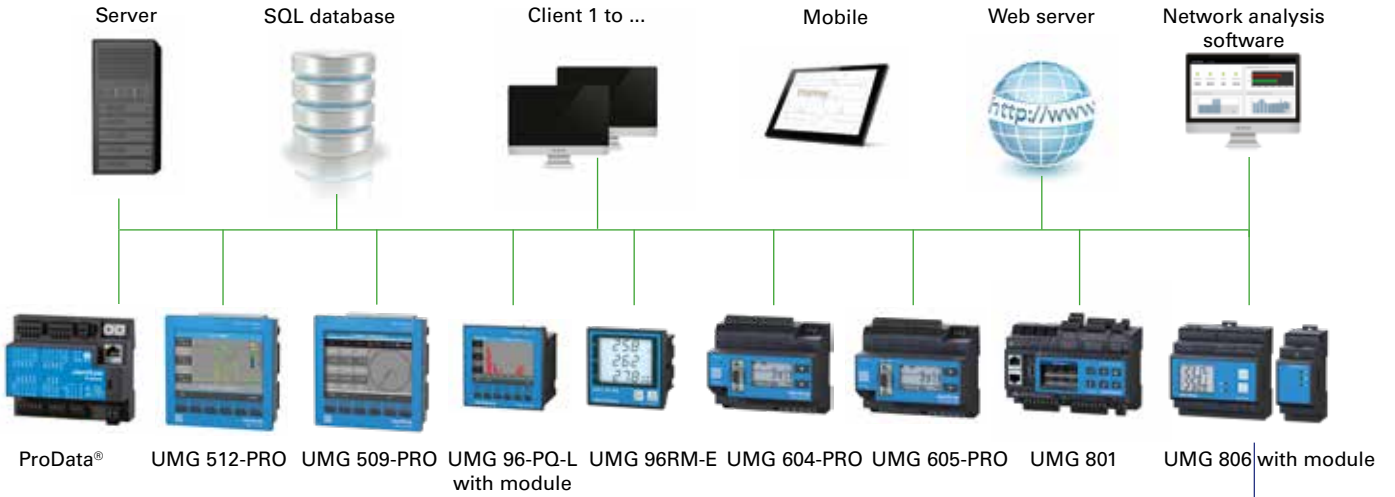
UMG 806		UMG 806 modules		UMG 96-S2	UMG 96RM (UL certified)						UMG 96-PA (UL certified)		UMG 96-PQ-L (UL certified)	UMG 96-PA & 96-PQ-L module (UL certified)	UMG 509-PRO (UL certified)	UMG 512-PRO (UL certified)		
EC1	ED1	EI1			P	M	E	CBM	EL	PN	96-PA	96-PA-MID+		RCM-EL				
14.02.025	14.02.016	14.02.019	14.02.020	52.34.002	52.22.061	52.22.064	52.22.069	52.22.062	52.22.066	52.22.068	52.22.090	52.32.001*11	52.32.004*8	52.36.001	52.32.010	52.26.001	52.17.011	
230 / 400 V AC				230 / 400 V AC	277 / 480 V AC						347 / 600 V AC (UL)*13 417 / 720 V AC (IEC)		347 / 600 V AC (UL)*13 417 / 720 V AC (IEC)		347 / 600 V AC (UL) 417 / 720 V AC (IEC)		347 / 600 V AC (UL) 417 / 720 V AC (IEC)	
400 V AC				-	480 V AC						-		-		600 V AC		600 V AC	
80 – 270 V AC; 80 – 270 V DC				90 – 265 V AC; 90 – 250 V DC	90 – 277 V AC; 90 – 250 V DC*11						90 – 277 V AC; 90 – 250 V DC*11		90 – 277 V AC; 90 – 250 V DC*11		95 – 240 V AC; 80 – 300 V DC*11		95 – 240 V AC; 80 – 300 V DC*11	
•/•				- / •	•/•						•/•		•/•		•/•		•/•	
4				4	4						4		4		4		4	
8 kHz				8 kHz	21.33/25.6 kHz						8.13 kHz		13.67 kHz		20 kHz		25.6 kHz	
-				-	-						-		-		-		-	
10 / 12				16 / 16	10 / 12						10 / 12		10 / 12		10 / 12		10 / 12	
1				-	-	-	-	2	-	-	2	-	-	-	2	2	2	
4			4*12	3	3	4	3	4	4	3	4	3*7	3*7	1	4	4	4	
1				-	-	-	-	2*4	-	-	2*4	-	-	1	1	1	1	
1 – 31.				1 – 15.	1 – 40.						1 – 40.		1 – 65.		1 – 63.		1 – 63.	
•				•	•						•		•		•		•	
•				-	-						-		-		-		-	
-				-	-						-		-		-		-	
-				-	-						-		-		> 50 µs		> 39 µs	
0.2%; 0.2%				0.2%; 0.2%	0.2%; 0.2%						0.2%; 0.2%		0.2%; 0.2%		0.1%; 0.2%		0.1%; 0.1%	
0.5S (.../5 A)				0.5S (.../5 A)	0.5S (.../5 A)						0.2S (.../5 A)		0.2S (.../5 A)		0.2S (.../5 A)		0.2S (.../5 A)	
-	4			-	4	-	(3)*3	4	-	(3)*3	3	3	3	3	2	2	2	
1	2	2		1	2	6	2	(5)*3	6	-	(5)*3*5	3	3	2	2	2	2	
-				-	-	-	-	-	-	-	1	1	1	-	-	-	-	
•				•	•						•		•		•		•	
4 MB				-	-	256 MB	-	256 MB	256 MB	-	-	8 MB	64 MB	256 MB	256 MB	256 MB	256 MB	
•				-	-						-		-		-		-	
-				-	Comparator						Comparator		Comparator		Jasic® (7 Prg.)		Jasic® (7 Prg.)	
-				-	-	-	-	•/•	-	-	•/•	-	-	-	•/•	•/•	•/•	
-				-	-						-		-		-		-	
-				-	-						-		-		-		-	
-				-	-						-		-		-		-	
GridVis®-Essential	GridVis®-Essential	GridVis®-Essential		GridVis®-Essential	GridVis®-Essential						GridVis®-Essential		GridVis®-Essential		GridVis®-Essential		GridVis®-Essential	
-				-	-						-		-		-		-	
•				•	•	•	-	•	•	-	•	•	•	•	•	•	•	
-				-	-	•	-	-	•	-	-	-	-	-	-	-	-	
-				-	-	•	-	-	-	-	-	-	-	-	-	-	-	
-				-	-	•	-	-	-	-	-	-	-	-	-	-	-	
-	•			-	-	-	-	-	-	•	2	-	-	•	•	•	•	
•				•	•	•	-	•	•	-	•	•	•	•	•	•	•	
-	•			-	-	•	-	-	-	-	-	-	-	•	•	•	•	
-				-	-	•	-	-	-	-	-	-	-	•	•	•	•	
-	•			-	-	-	-	-	-	•	*16	-	-	•	•	•	•	
-				-	-	-	-	-	-	-	-	-	-	•	•	•	•	
-				-	-	-	-	•*2	-	-	-	-	-	-	•*2	•*2	•*2	
-				-	-	-	-	-	-	-	•	-	-	-	-	-	-	

\*8 MID-certified  
 \*9 On the basic device  
 \*10 For polling the slave device  
 \*11 Combined function: optionally operating and residual current  
 \*12 These are 4...20 mA signal inputs  
 \*13 230 / 400 V AC (acc. to UL) at MID/MID+ variants  
 \*14 90 – 300 V AC (item no. 14.02.001)  
 12 – 24 V DC (item no. 14.02.009)  
 \*15 Subject to external CT accuracy  
 \*16 In combination with the AC split core current transformers CT-SC-010, CT-SC-012, CT-SC-024, CT-SC-036  
 Comment: For detailed technical information, please refer to the respective operating instructions and the Modbus address lists.

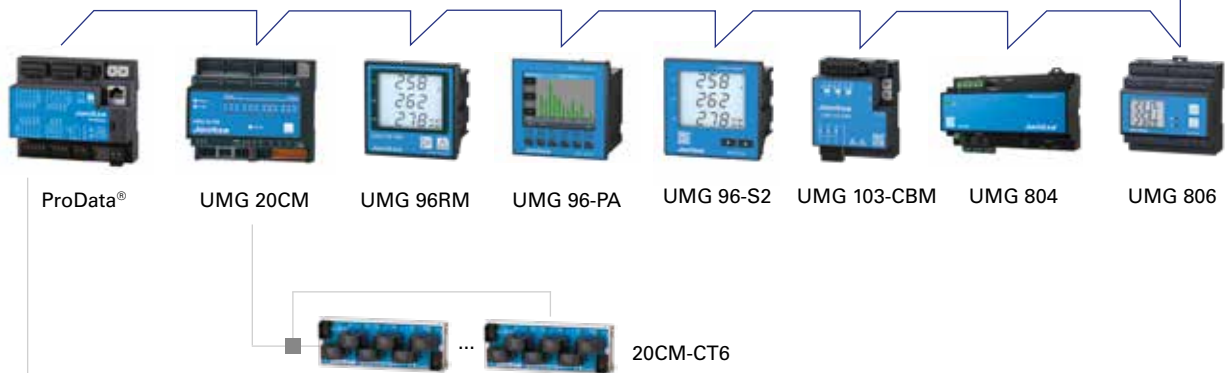
# Chapter 02

## Energy and power quality measurement products

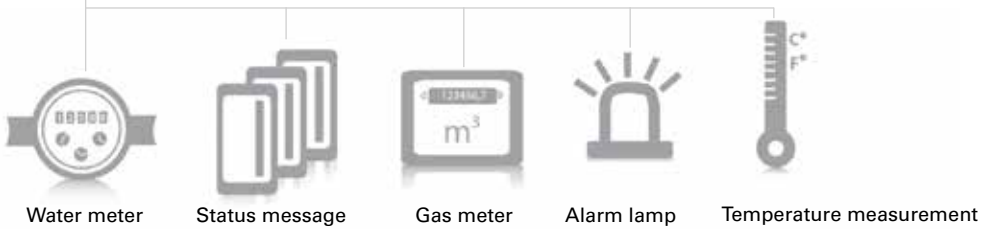
### Ethernet level (TCP/IP)



### Fieldbus level (e.g. Modbus RTU)



### Fieldbus level (e.g. Modbus RTU)



# UMG 103-CBM

Compact energy measurement device for DIN rails

Harmonics



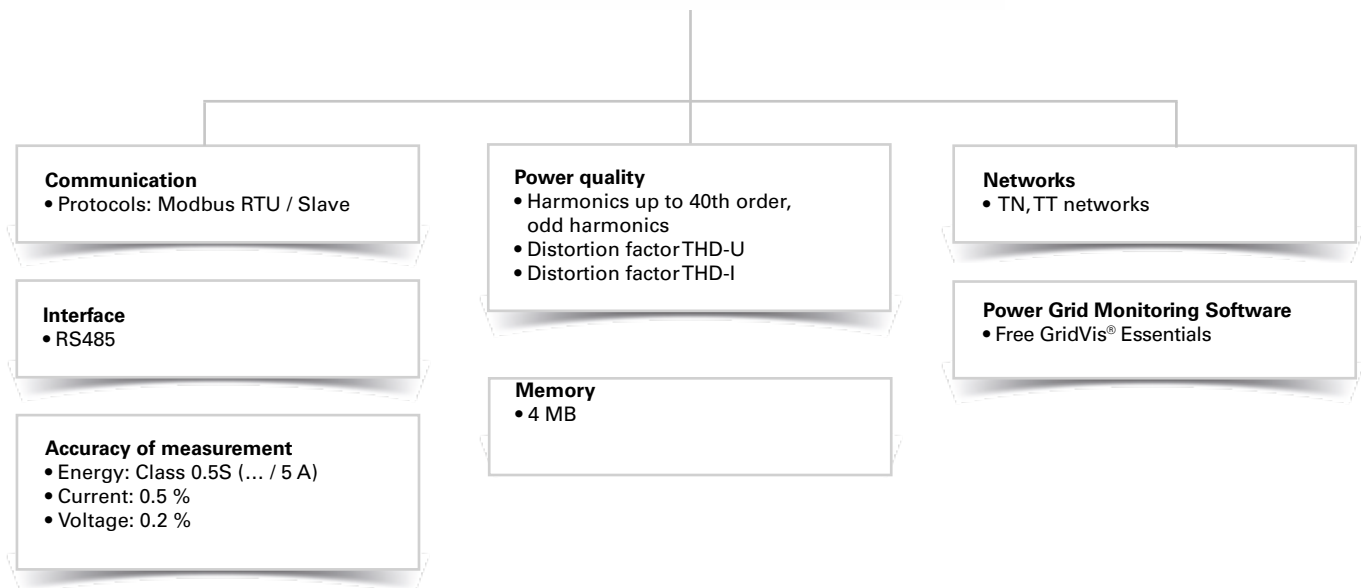
Modbus interface



GridVis®  
Power Grid Monitoring  
Software



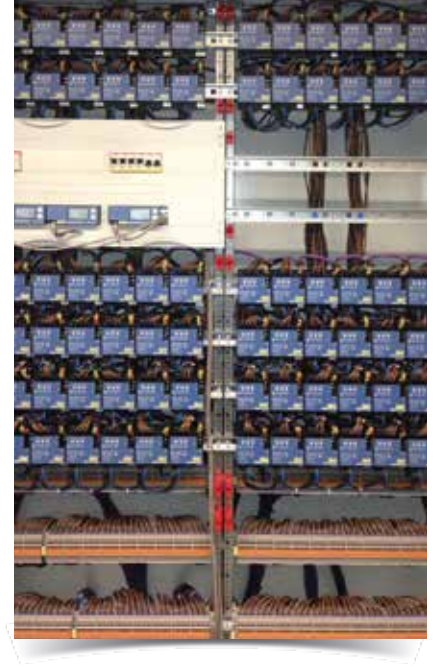
Measurement accuracy 0.5



## Areas of application



- Measurement and checking of electrical characteristics and energy consumption in energy distribution systems
- Cost centre management
- Threshold value monitoring, measured value transducer for building management systems or PLC
- Monitoring of harmonics



## Main features



### Power quality

- Harmonics analysis up to 40th harmonic, odd harmonics
- Distortion factor THD-U / THD-I
- Minimum and maximum values
- Measurement of positive, negative and zero sequence component

### Features

- 3 Voltage measurement inputs (300 V CAT III)
- 3 Current measurement inputs
- Continuous sampling of voltage and current measurement inputs
- Measurement of the reactive distortion power
- Sampling frequency 5.4 kHz
- Transfer of the measured values via a serial interface
- Supply voltage via measurement voltage L1-N, L2-N and L3-N

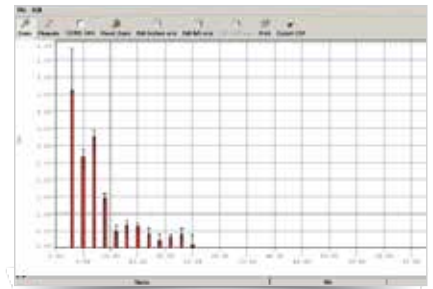


Fig.: GridVis® – Harmonics analysis (FFT)

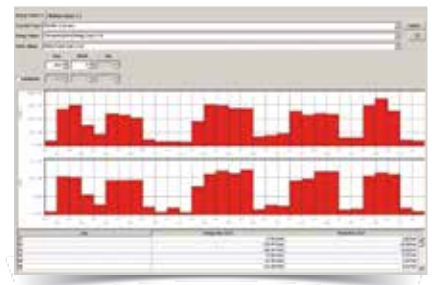
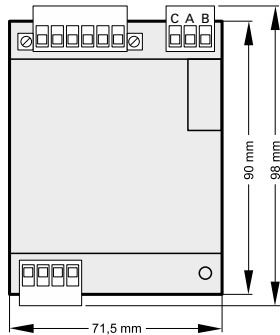


Fig.: GridVis® – Device dashboard with energy analysis

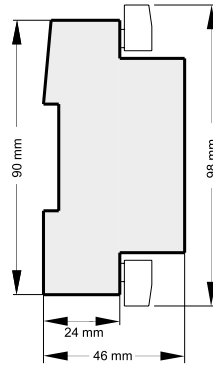


## Dimension diagrams

All dimensions in mm



Front view



Side view

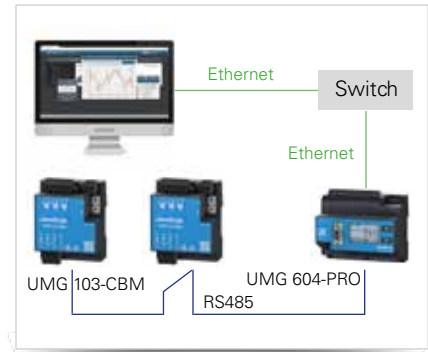


Fig.: Connection of multiple UMG 103-CBMs to a PC via a UMG 604-PRO (with Ethernet option)



## Typical connection

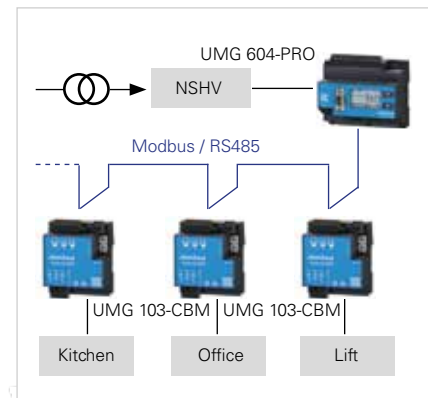
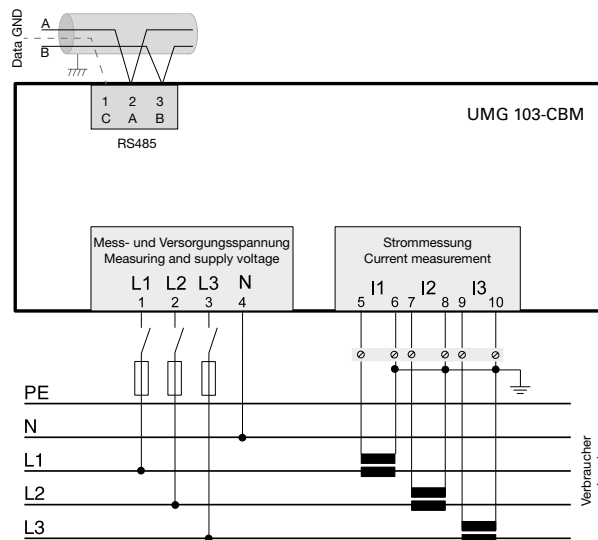


Fig.: Topology example UMG 604-PRO (Master) – UMG 103-CBM (Slave)

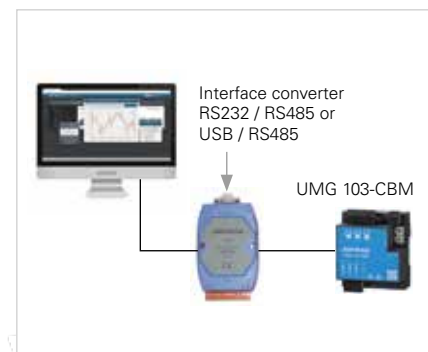


Fig.: Connection of a UMG 103-CBM to a PC via an interface converter



## Device overview and technical data

UMG 103-CBM	
Item number	52.28.001
<b>General</b>	
Net weight (with attached connectors)	approx. 200 g (0.44 lb)
Device dimensions (W x H x D)	71,5 x 98 x 46 mm (2.82 x 3.86 x 1.18 in)
<b>Ambient conditions during operation</b>	
The device <ul style="list-style-type: none"> <li>• should be used in a stationary and in a weatherproof location.</li> <li>• meets the operating conditions according to DIN IEC 60721-3-3</li> <li>• has protection class II according to IEC 60536 (VDE 0106, part 1) and does not require a ground wire connection.</li> </ul>	
Working temperature range	-25 °C .. +60 °C (-13 °F..to 140 °F)
Relative humidity	5 to 95% (at +25 °C/77 °F) without condensation
Operating altitude	0 to 2000 m above sea level
Pollution degree	2
Housing flammability rating	UL94V-0
Installation position	any
Ventilation	No forced ventilation required.
Fastening/assembly	DIN rail 35 mm as per IEC/EN60999-1, DIN EN50022
Impact stress	2 Joule, IK07 as per IEC/EN61010-1:2010
Protection against ingress of solid foreign bodies and water	IP20 in accordance with EN60529, September 2000, IEC60529:1989
<b>Measurement data recording</b>	
Memory (Flash)	4 MB, (1024 sectors. each 4kB)
Data record storage (all profiles activated)	approx. 16000 records
Battery (soldered in) , typical life expectancy	BR 1632, 3V, 8 - 10 years
<b>Transport and storage</b>	
The following information applies to devices which are transported or stored in the original packaging.	
Free fall	1 m
Temperature	-20 °C bis +70 °C (-4 °F to 158 °F)
<b>Supply voltage</b>	
The device derives the supply voltage from the measured voltage!	
Supply from single phase	115 - 277 V (±10%), 50/60 Hz
Supply from three phases	80 - 277 V (±10%), 50/60 Hz
Power consumption	max. 1.5 VA



<b>Voltage measurement</b>	
3-phase 4-conductor systems with rated voltages (L-N/L-L)	Max. 277 V/480 V
Networks	Measurement in TT and TN networks
Measurement voltage surge	4 kV
Protection of voltage measurement	1 - 10 A trigger characteristic B, (with IEC-/UL approval)
Overvoltage category	300 V CAT III
Resolution	0.01 V
Crest factor	2 (based on 240 V <sub>rms</sub> )
Sampling rate	5.4 kHz
Frequency of the fundamental oscillation	45 Hz to 65 Hz
resolution	0.001 Hz
Fourier analysis	1-40. harmonic

<b>Current measurement</b>	
Rated current	5 A
Rated current	6 A
Crest factor	2 (based on 6 A <sub>rms</sub> )
Resolution	0.1 mA
Metering range	0.005 to 6 A <sub>rms</sub>
Overvoltage category	300 V CAT II
Measurement voltage surge	2 kV
Power consumption	approx. 0.2 VA (Ri=5 mΩ)
Overload for 1 sec.	60 A (sinusoidal)
Sampling rate	5.4 kHz

<b>Terminal connection capacity</b>	
Connectable conductors. Connect only one conductor per terminal!	
Single core, multi-core, fine-stranded	0.08 - 2.5 mm <sup>2</sup> , AWG 28 - 12
Tightening torque	max. 0.5 Nm
Stripping length	min. 8 mm

<b>RS485 interface</b>	
Protocol, Modbus RTU	Modbus RTU/slave
Transmission rate	9.6 kbps, 19.2 kbps, 38.4 kbps, 57.6 kbps, 115.2 kbps, automatic detection

<b>Firmware</b>	
Firmware update	Please observe the operating instructions

Comment: For detailed technical information please refer to the operation manual and the Modbus address list.

Typical application illustration with 2 supplies

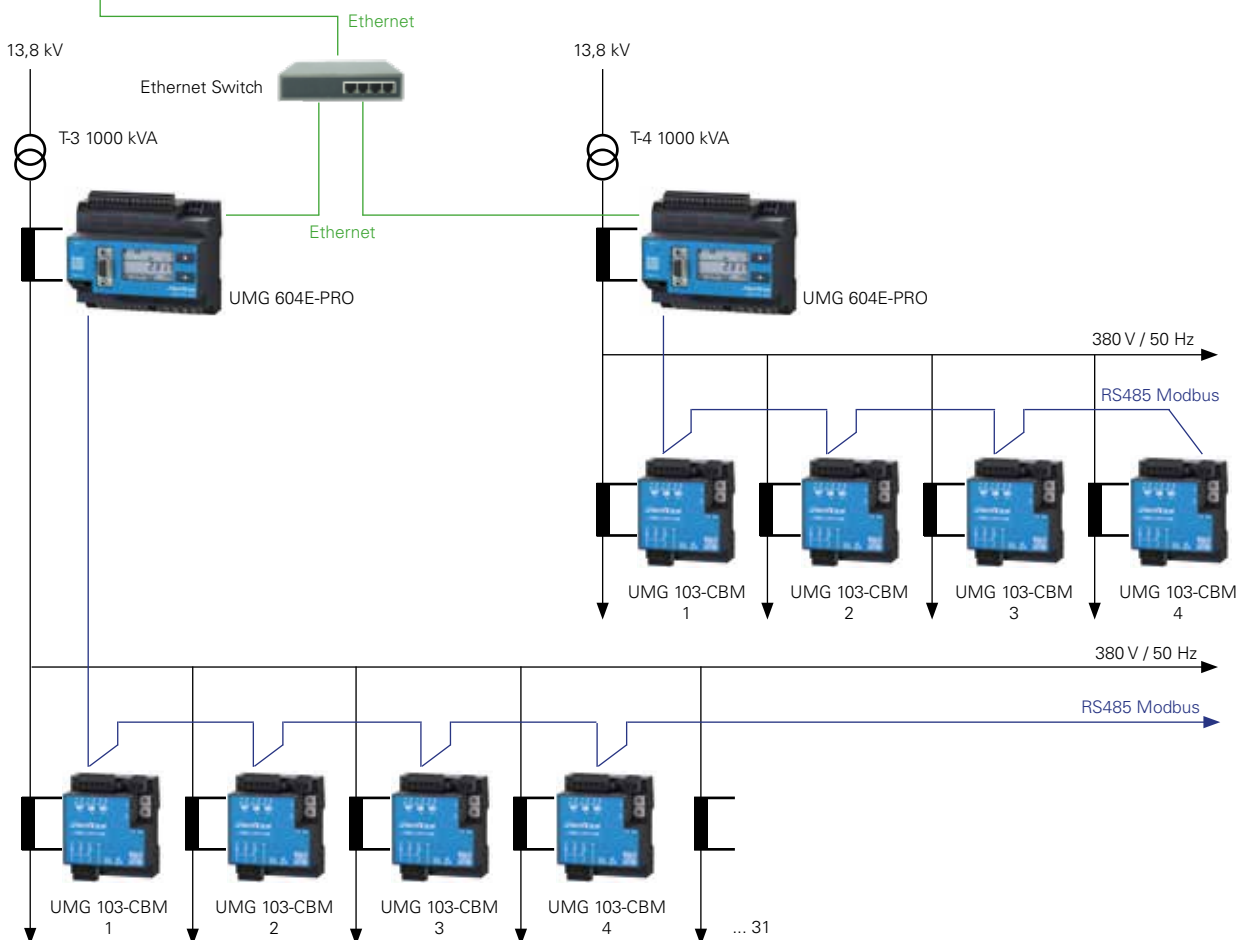
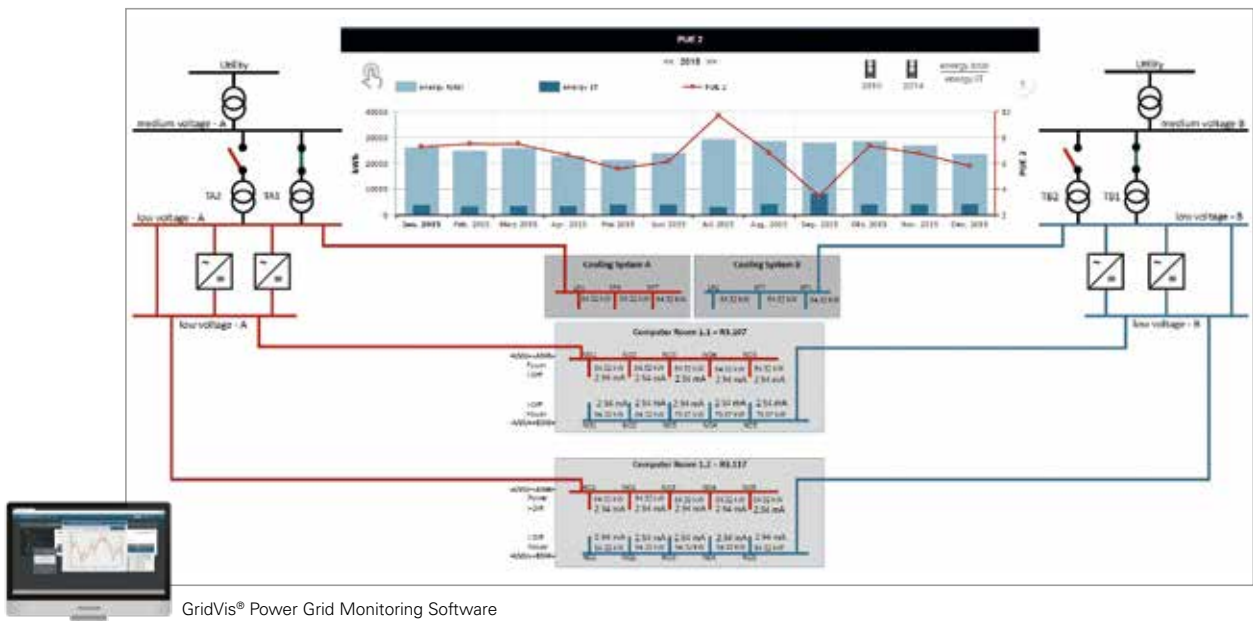
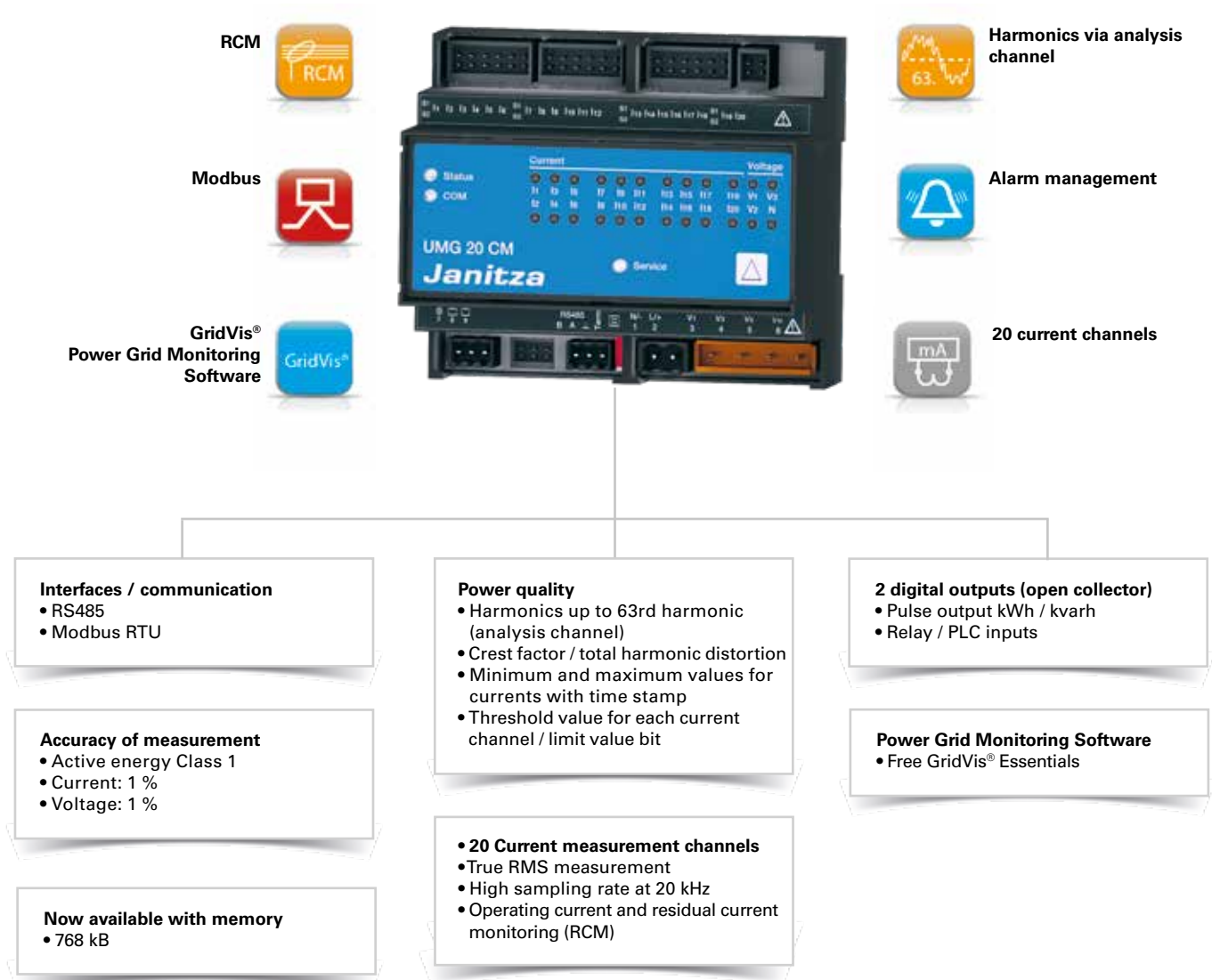


Fig.: Typical application illustration with 2 supplies, UMG 604E-PRO as master measurement device in the main power supply and UMG 103-CBM for measuring the low voltage feeder.

# UMG 20CM

Operating current and residual current measurement device





## Areas of application



- Continuous acquisition of the operating currents
- Permanent residual current monitoring
- Messages in the event of the nominal current being exceeded
- Energy acquisition for complete current distribution
- Cost centre accounting
- Transparency of energy costs
- More effective use of IT infrastructure
- PDUs in data centres
- Increase of up time power supply

## Main features



### RCM and energy measurement device in a single unit

- 20 current measurement channels +/- 0.5 %
- 3 voltage measurement channels +/- 0.5 %
- Internal RS485 interface (Modbus as Slave)
- 20 LEDs – One LED for each current channel (Green = o.k., Yellow = Warning; Red = Nominal current exceed)
- Measurement range of operation current with burden up to 63 A with closed or split core current transformers (standard measured values: V, A, kW, kVA, kVar, kWh)

### The system for smart people

- Compact nature of the system
- Can be retrofitted to existing systems
- Modbus RTU directly on board
- State indication per channel (LEDs)
- Name stored per channel in the measurement device
- Polarity reversal for the current channels
- Memory function for the messages of the threshold monitoring
- Wide range power adapter (90 – 276 V ... AC / DC)
- Integration in the GridVis® Power Grid Monitoring Software
- Diverse current transformer variants for the individual application
- Measurement variants:
  - Three-phase and single-phase energy measurement
  - RCM measurement three-phase and single-phase
- High sampling rate 20,000 Hz
- Current transformer connection monitoring (i.e. wire break will be detected)
- Harmonics analysis up to 63rd harmonic via analysis channel
- Saving of minimum and maximum values with time stamp
- Standard measured values: V, A, kW, kVA, kVar, kWh (variable list)
- Scalability of the system

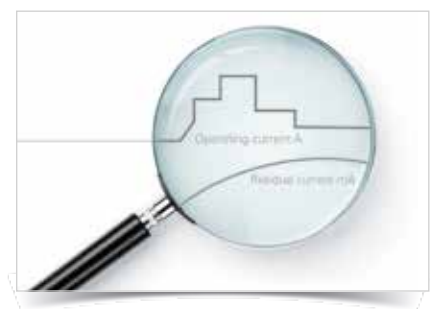


Fig.: Operating current and RCM fault current monitoring

# The system

## Power supply without drop-outs

- Permanent monitoring and logging of processes in TN-S or TN-C-S systems
- Simple parameterisation and operation of the RCM measurement
- Automatic reporting in the event of problems enables a rapid initiation of countermeasures
- Comprehensive diagnostics increase safety and efficiency of a company



## Alarms before failures (preventative residual current analysis)

- Faults arising will be detected in good time
- Monitoring, evaluation and reporting of creeping increases in residual currents (e.g. triggered by insulation faults and operating currents for system parts or loads being too high)
- Reduction of downtimes

## Sensors for energy management

- Energy data of a large number of loads can be acquired and passed to a database with ease
- Automatic reading out and saving of the measured values and data saved in the measurement devices as well as the exceedance of parameterised threshold values
- Channel-specific measured values of the current monitoring devices can be displayed via the GridVis® Power Grid Monitoring Software
  - The progression of measured values is visualised graphically
  - Display of warnings or fault messages possible, e.g. via the topology views.
  - Associated message texts can be freely configured for this
  - Automatic sending of an email in the event of operational or fault messages
  - Remote monitoring of the entire system is possible via internet
  - Residual current and operational current monitoring devices can be parameterised via GridVis® (Modbus)
- The evaluation and saving of data in central databases is implemented via the GridVis® Power Grid Monitoring Software
- The greater the scope of information, the more accurate the determination of savings potentials
- Energy optimisation offers a higher, more economical savings potential (ISO 50001)

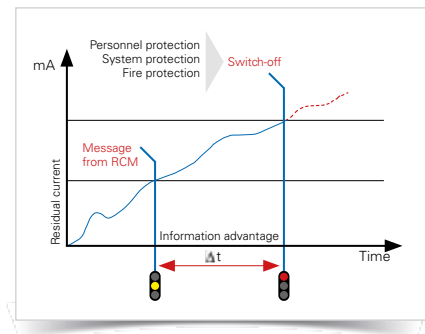


Fig.: Message before shut-down - an objective of residual current monitoring

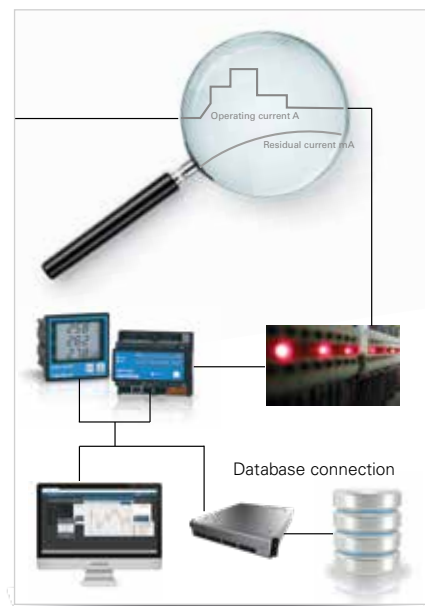


Fig.: Read-out, analysis and saving of energy data

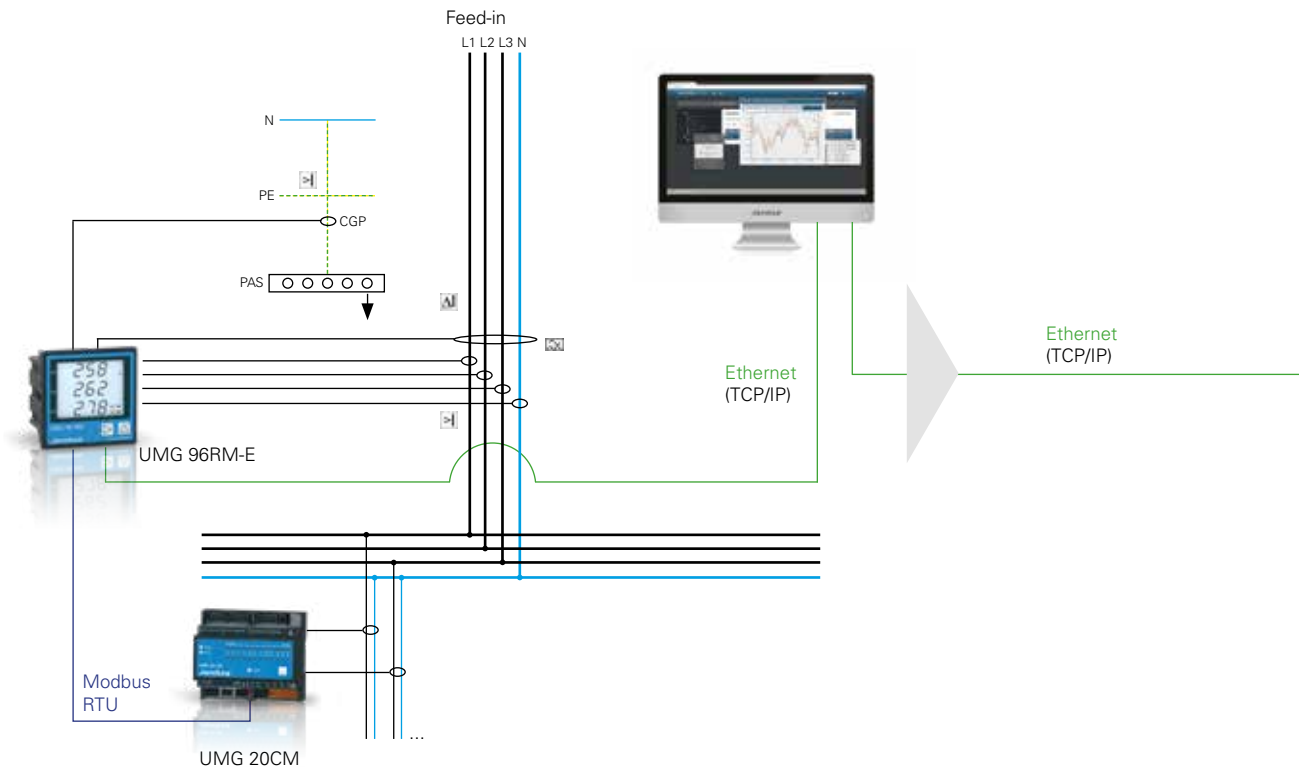


Fig.: The 20 channels of the UMG 20CM can be optionally used for residual current or operational current monitoring by utilising the corresponding current measurement transformer. In the case of residual current monitoring, the residual currents flowing to ground or any other path are acquired.

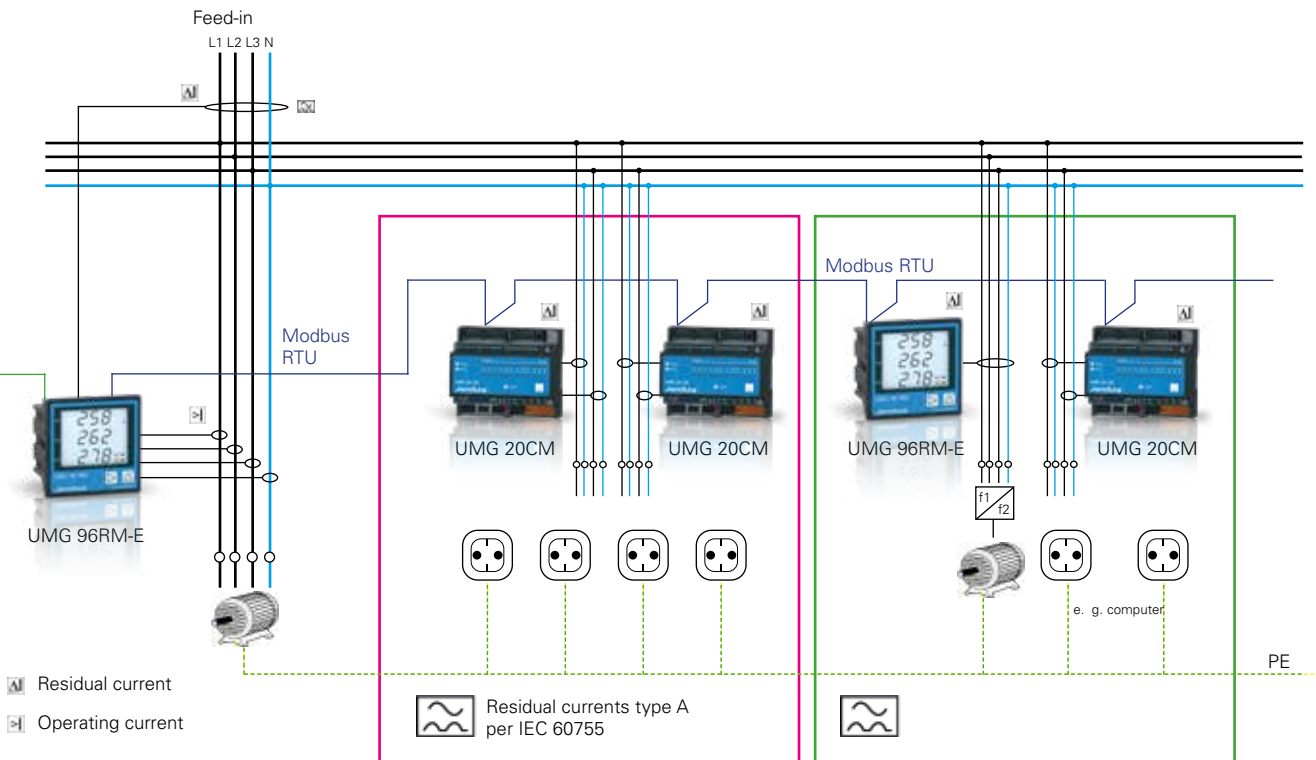
## Your benefits

### The intelligent system solution

- Early warning with system failures
- Avoidance of costly and hazardous system downtimes; the availability of systems is increased
- Localisation of individual faulty feeders, reduced work when troubleshooting
- Early detection of an overloading of the N conductor and critical residual currents, resulting in increased fire safety
- Through parameterisation of the system in new condition and constant monitoring, all changes to the system state after the point of commissioning can be detected
- Fulfilment of the safety criteria "RCM residual current monitoring" in data centres
- Convenient monitoring and parameterisation solution with GridVis® Power Grid Monitoring Software
- Operating current acquisition of all relevant consumers as a basis for an energy management system (EnMS)

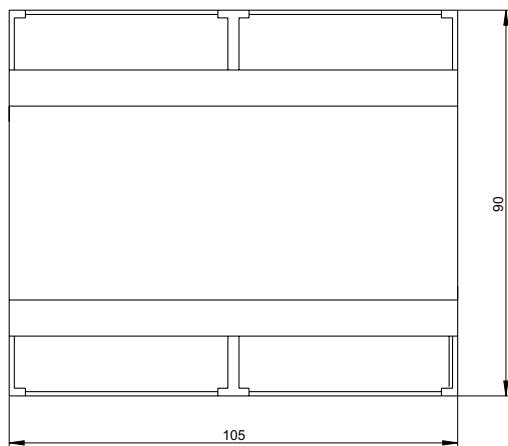


Fig.: Residual current transformer for the acquisition of residual currents. Different configurations and sizes allow use in almost all applications (see chapter 06, current / voltage transformers and sensors).

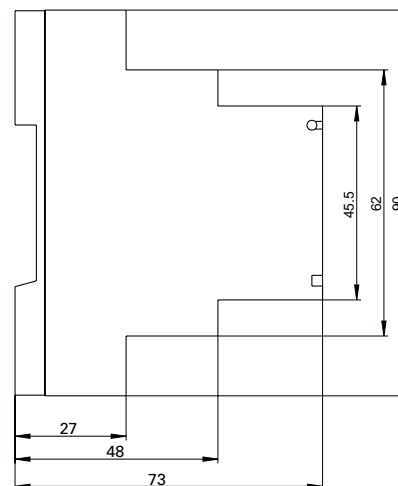


## Dimension diagrams

All dimensions in mm



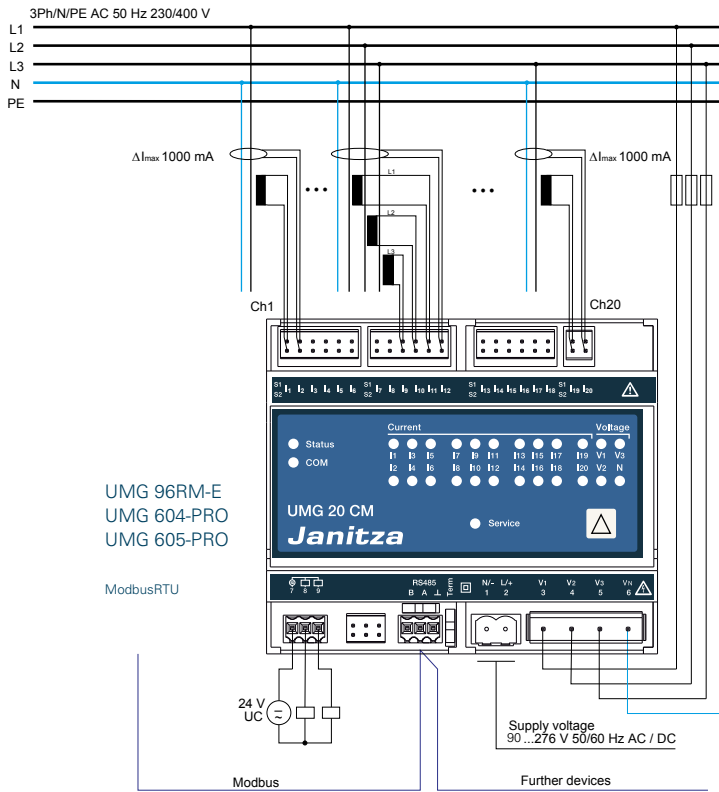
Front view



Side view



## Typical connection



Recommendation: The bus should not contain more than 10 devices, type UMG 20CM if several UMG 20CM measuring channels are used. If the APP "20CM-Webmonitor" is used, the number is limited to 5 devices due to the APP management).



## Device overview and technical data

		UMG 20CM
<b>Item number</b>		14.01.625
Operating voltage		90 to 276 V AC / 90 to 276 V DC
<b>General information</b>		
Type of measurement		Continuous real effective value measurement up to the 63rd harmonic
Operating voltage		90 ... 276 V AC and DC
Measurement in quadrants		4
TN, TT, IT networks		TN, TT, IT
Measurement in single-phase/multi-phase networks		1 ph, 2 ph, 3 ph and up to 20 times 1 ph
<b>Measured voltage input</b>		
Overvoltage category		300 V CAT III
Measured range, voltage L-N, AC (without transformer)		1 to 300 Vrms
Measured range, voltage L-L, AC (without transformer)		10 to 480 Vrms
Resolution		0.1 V
Impedance		1.3 MΩ / Phase
Frequency measuring range		45 to 65 Hz
Sampling frequency		20 kHz / phase



Measured current input	
Evaluation range of the operating current	0 to 630 A
Evaluation range of the residual current	10 mA ... 1 A/50 mA ... 15 A **
Resolution	1 mA
Cut-off frequency	3.2 kHz
Relative deviation	+/- 1%
* Caution: Available with firmware 8.0 and higher	
** With additional resistance of 3,9 Ω (item no.: 15.03.086)	

Monitoring function	
Response function	0 ... 650 s
Reset delay	0 ... 650 s
Triggering the delay	10 ms

Digital inputs and outputs	
Number of digital outputs	2
Switching voltage	max. 60 V DC, 30 V AC
Maximum current	350 mA
Switch-on resistance	2 Ω
Maximum line length	up to 30 m unshielded, from 30 m shielded

Power consumption	
Power consumption	3 W (7 AV)
Voltage inputs 1 ph/3 ph	40 mW/120 mW
Current inputs (single)	max. 10 mW (at 0,8 Ω load)

Mechanical properties	
Weight	270 g (0.6 lb)
Device dimensions in mm (W x H x D)	105 x 90 x approx. 73 (4.13 x 3.54 x 2.87 in)
Protection class per EN 60529	IP20
Assembly per IEC EN 60999-1 / DIN EN 50022	35-mm-DIN top-hat rail

Connection capacity of the terminal points (voltage and current measurement)	
Connectable conductor; <b>Only one conductor must be connected per terminal point!</b>	
Single core wire, multiple core wire, finely stranded	0.2...1 mm <sup>2</sup> , AWG 26-12 (current) 0.08...4.0 mm <sup>2</sup> , AWG 28-12 (voltage)
Pin-type cable lugs, end sleeves	0.2... 2.5 mm <sup>2</sup>
Tightening torque	0.4 ... 0.5 Nm
Stripping length	7 mm

Environmental conditions	
Temperature range	Operation: K55 (-10 °C ... +55 °C) (14 °F.to 131 °F)
Relative humidity	Operation: 5 ... 95% (at 25 °C)
Operating altitude	0 ... 2000 m above sea level
Degree of pollution	2
Mounting position	any

Electromagnetic compatibility	
Electromagnetic compatibility of equipment	Directive 2004/108/EG
Electrical equipment for use within certain voltage limits	Directive 2006/95/EG

Equipment safety	
Safety requirements for electrical equipment for measurement, control, and laboratory use	
Part 1: General requirement	IEC/EN 61010-1
Part 2-030: Particular requirements for testing and measuring circuits	IEC/EN 61010-2-030

Immunity from interference	
Class A: Industrial area	IEC/EN 61326-1
Electrostatic discharge	IEC/EN 61000-4-2
Voltage drops	IEC/EN 61000-4-11

Emissions	
Class B: Residential area	IEC/EN 61326-1
RFI field strength 30 ... 1000 MHz	IEC/CISPR11/EN 55011
Radiated interference voltage 0.15 ... 30 MHz	IEC/CISPR11/EN 55011

Safety	
Europe	CE labelling

For detailed technical information please refer to the operation manual and the Modbus address list.

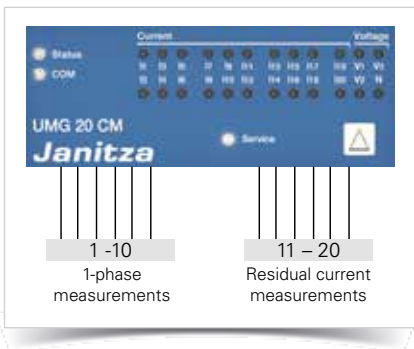


Fig.: 10 single-phase operational current measurements, 10 single-phase residual current measurements,

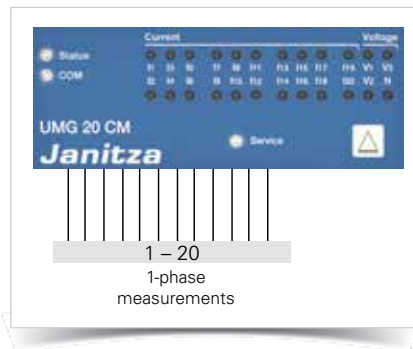


Fig.: 20 single-phase operating current or RCM measurements

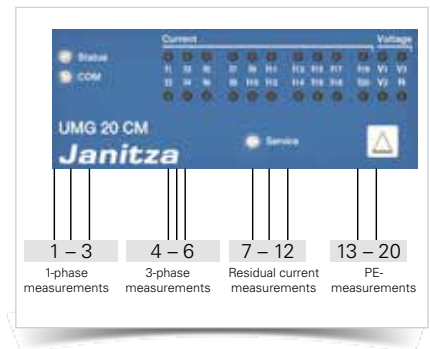


Fig.: 3 single-phase operational current measurements, 1 three-phase operational current measurement, 6 single-phase residual current measurements, 8 single-phase PE measurements

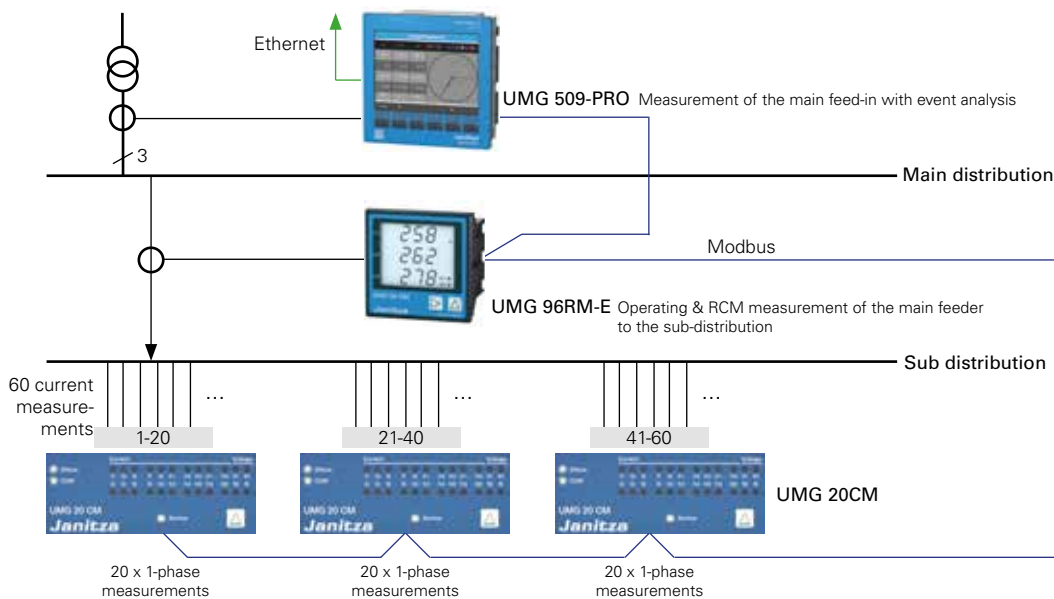


Fig.: Extremely compact solution for complete monitoring via three levels with leading-edge master-slave communication architecture

# Modular extension for the UMG 20CM measuring device

## Areas of application



- Industry sector
- Data centers
- Commercial buildings
- Building installations on distribution boards, circuit breakers and busbar trunking systems



## Main features

### 20CM-CT6 module at a glance

- The 20CM-CT6 module serves as an extension of the UMG 20CM basic device
- A maximum of 16 modules with six channels each (a total of up to 96 channels) can be added
- The measured data from all of the modules is accessible via the UMG 20CM
- Internal communication and power supply via CAN bus interface
- Acquisition of measured values via integrated current transformers
- Memory for historical data
- RCM diagnostics variables on board
- Status of limit value monitoring displayed by six LEDs

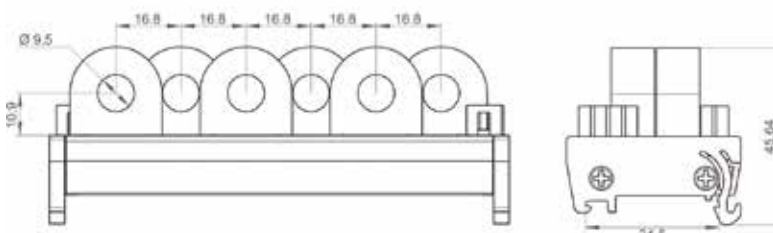


Fig.: Device dimensions in mm

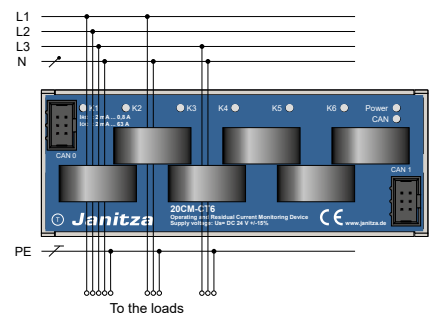


Fig.: Residual current measurement

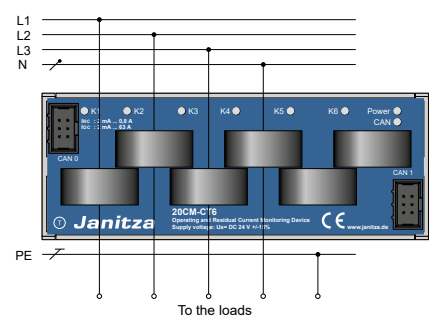


Fig.: Operating current measurement, e.g. 6 x 1-phase



## Device overview and technical data

		Modul 20CM-CT6
Item number		14.01.626
<b>General information</b>		
Device dimensions in mm (W x H x D)	119 x 47 x 45 (4.69 x 1.85 x 1.77 in)	
Net weight	170 g (0.37 lb)	
Operating mode	Continuous operation	
Protection type per DIN EN 60529	IP20	
Protection class	III	
Flammability rating	UL-V0	
The device fulfills the requirements according to the standards	EN 62020:1998+A1:2005, (VDE 0663):2005	
<b>Ambient conditions</b>		
Temperature range (operation)	-10 °C to +55 °C (14 °F. to 131 °F)	
Storage temperature	-25 °C to +70 °C (-13 °F. to 158 °F)	
Altitude	0 to 2000 m above sea level	
Relative humidity (operation)	5 to 95% (at 25 °C/77 °F)	
Pollution degree	3	
Installation position	vertical/horizontal	
Assembly	35 mm top hat rail per DIN EN 60175	
<b>Supply voltage</b>		
Supply voltage Us (via internal bus)	DC 24 V (± 10%, PELV)	
Power consumption (internal consumption)	2 W	
<b>Measurement</b>		
Type of measurement	Continuous true effective value measurement up to the 63rd harmonic	
Measurement in quadrants	4	
Systems	TN, TT, IT	
Measurement in single-phase/multi-phase networks	1 ph, 2 ph, 3 ph and up to 6 times 1 ph	
Number of measuring channels	6	
Number of measuring channels in the bus segment	max. 96	
Measured value recording	parallel, effective value measurement (true RMS)	
Rated voltage (current measurement transformer)	AC 250 V	
Rated frequency (current measurement transformer)	50 Hz	
Operating trigger current	AC 2 mA ... 63 A	
Residual trigger current	AC 2 mA ... 1 A	
Resolution	2 mA ... 1 A 1 A ... 63 A	0.5 mA 35 mA
Cut-off frequency	3.3 kHz	
Relative deviation (metering range)	± 0.5 %	
Frequency range	45 ... 65 Hz	
<b>Monitoring function</b>		
Response function	0 ... 650 s [10 ms]	
Reset delay	0 ... 650 s [10 ms]	
Resolution of the delay	10 ms	
<b>Communication interface/protocol</b>		
Interface	2 x CAN/CAN 2.0 (according to ISO 11898)	
Protocol	CANopen	
CAN bus connection type (CAN bus connector)	2 x 6-pin IDC connector	
Connection cross section (single core/fine-stranded)	max. 9.3 mm (all cables and individual cores)	
<b>Display and messages</b>		
Displays (operating and communication status) (power of the measuring channels)	2 x multi-color LED 6 x multi-color LED	
Messages	LED/CAN-Bus	
<b>Accessories<sup>*1</sup></b>		
LCAN-RS45 incl. 2 cables (each 2 m ribbon cable, 1 x with 2 IDC-connector and 1 x with 3 IDC-connectors)	Item no. 08.02.447	

The following is included in the scope of delivery of module 20CM-CT6:  
1 connection cable  
(ribbon cable 20 cm with 2 IDC-connectors)

\*1 Separate power supply with 24 V DC required

# UMG 604-PRO

## Power analyzer

Harmonics



Memory 128 MByte



Events



Modbus master,  
Ethernet gateway



Homepage



Graphic  
programming

### Communication

- Profibus (DP/ V0)
- Modbus (RTU, UDP, TCP, Gateway)
- TCP/IP
- BACnet (optional)
- HTTP (configurable homepage)
- FTP (file transfer)
- SNMP
- TFTP
- NTP (time synchronisation)
- SMTP (email function)
- DHCP

### Interfaces

- Ethernet
- RS232
- RS485

### Accuracy of measurement

- Energy: Class 0.5S (... / 5 A)
- Current: 0.2 %
- Voltage: 0.2 %

### Peak demand management (optional)

- Up to 64 switch-off stages

### Power quality

- Harmonics up to 40th harmonic
- Short-term interruptions (> 20 ms)
- Transient recorder (> 50  $\mu$ s)
- Starting currents (> 20 ms)
- Unbalance
- Full wave effective value recording (up to 4.5 min.)

### Networks

- IT, TN, TT networks
- 3 and 4-phase networks
- Up to 4 single-phase networks

### Measured data memory

- 128 MByte Flash

### Programming language

- Jasic®

### 2 digital inputs

- Pulse input
- Logic input
- State monitoring
- HT / LT switching

### 2 digital outputs

- Pulse output kWh / kvarh
- Switch output
- Threshold value output
- Logic output

(expandable via external I/O modules, see FBM modules in chapter 05)

### Temperature measurement

- PT100, PT1000, KTY83, KTY84

### Power Grid Monitoring Software

- Free GridVis® Essentials



## Areas of application



- Master device for energy management systems, (e.g. ISO 50001)
- Measurement, monitoring and checking of electrical characteristics in energy distribution systems
- Consumption data acquisition
- Monitoring of the power quality (harmonics, short-term interruptions, transients, starting currents, etc.)
- Measured value transducer for building management systems or PLC
- Control tasks e.g. depending on measured value or limit values being reached
- Peak demand management
- Ethernet gateway for subordinate measurement points
- Remote monitoring

## Main features



### Power quality

- Harmonics analysis up to 40th harmonic
- Unbalance
- Distortion factor THD-U /THD-I
- Measurement of positive, negative and zero sequence component
- Short-term interruptions (> 20 ms)
- Logging and storage of transients (> 50  $\mu$ s)
- Start-up processes
- Fault recorder function
- Rotary field indication

### DIN mounting rail (6TE):

#### Simple and cost-optimised installation

- Mounting on a 35 mm DIN rail
- Clear cost advantages in the switch cabinet construction through lower installation and connection effort
- Simple integration into the LVDB, in machinery construction, in installation subdistribution panel for building management systems, in IT and in data centres



### Modern communications architecture via Ethernet

- Rapid, cost-optimised and reliable communication through integration into an existing Ethernet architecture
- Integration in PLC systems and building management systems
- High flexibility due to the use of open standards
- Simultaneous polling of interfaces possible



Fig.: DIN rail mounting (6TE)

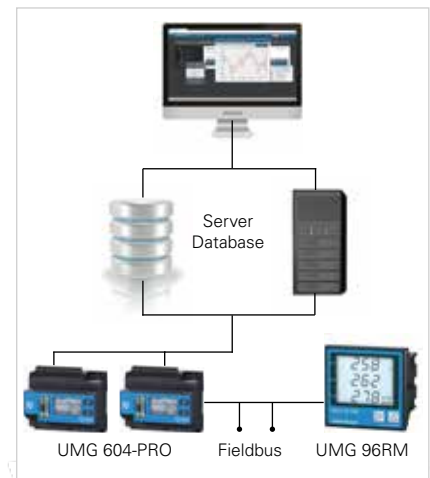


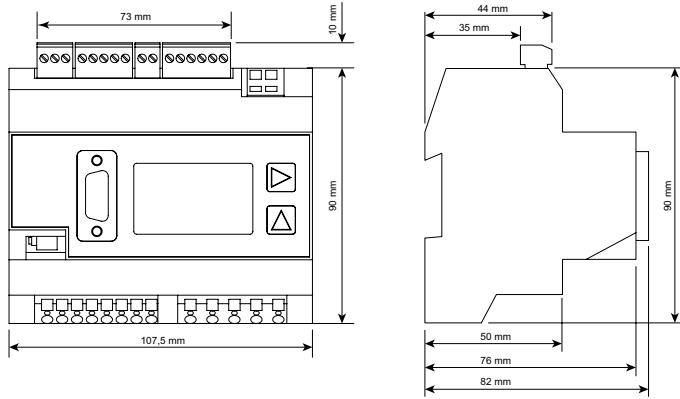
Fig.: Modern communication architecture





## Dimension diagrams

All dimensions in mm

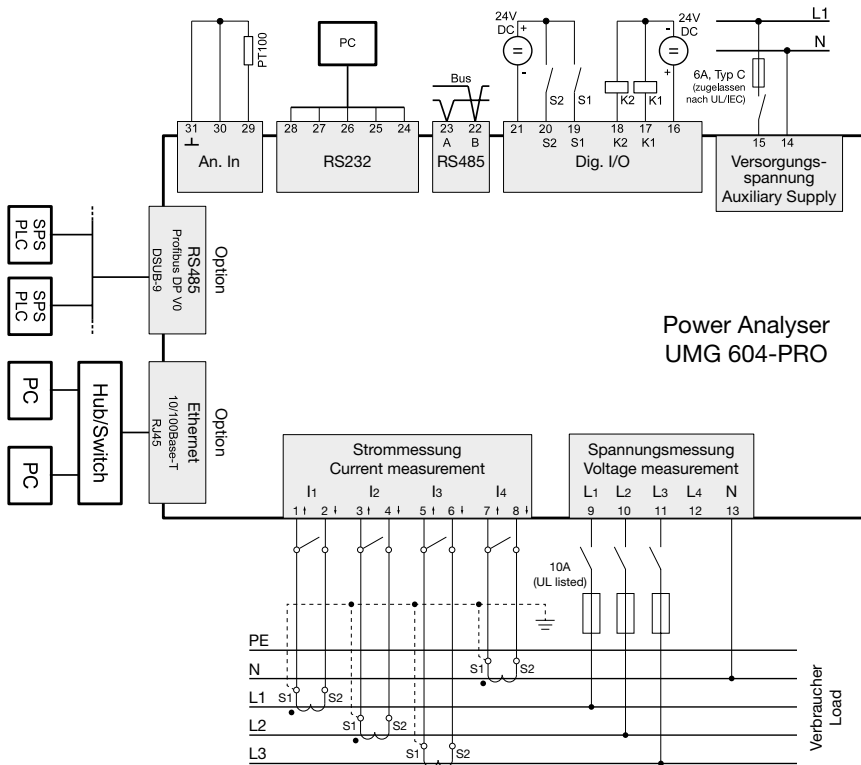


Front view

Side view



## Typical connection







## Device overview and technical data

Item number	UMG 604E-PRO			UMG 604EP-PRO	
	52.16.202	52.16.012	52.16.222	52.16.201	52.16.221
Item number (UL)	52.16.202	-	52.16.222	52.16.201	52.16.221
AC supply voltage	95 to 240 V AC	50 to 110 V AC	20 to 50 V AC	95 to 240 V AC	20 to 50 V AC
Supply voltage DC	135 to 340 V DC	50 to 155 V DC	20 to 70 V DC	135 to 340 V DC	20 to 70 V DC
<b>Communication</b>					
<b>Interfaces</b>					
RS485: 9.6 – 921.6 kbps (screw-type terminal)	•	•	•	•	•
RS232: 9.6 – 115.2 kbps (screw-type terminal)	•	•	•	•	•
Profibus DP: Up to 12 Mbps (DSUB-9 plug)	-	-	-	•	•
Ethernet 10/100 Base-TX (RJ-45 socket)	•	•	•	•	•
<b>Protocols</b>					
Modbus RTU, Modbus TCP, Modbus RTU over Ethernet	•	•	•	•	•
Modbus gateway for master-slave configuration	•	•	•	•	•
Profibus DP V0	-	-	-	•	•
HTTP (homepage configurable)	•	•	•	•	•
SMTP (email)	•	•	•	•	•
NTP (time synchronisation)	•	•	•	•	•
TFTP (automatic configuration)	•	•	•	•	•
FTP (file transfer)	•	•	•	•	•
SNMP	•	•	•	•	•
DHCP	•	•	•	•	•
TCP/IP	•	•	•	•	•
BACnet (optional)	•	•	•	•	•
ICMP (Ping)	•	•	•	•	•
<b>Device options</b>					
BACnet communication	52.16.081	52.16.081	52.16.081	52.16.081	52.16.081

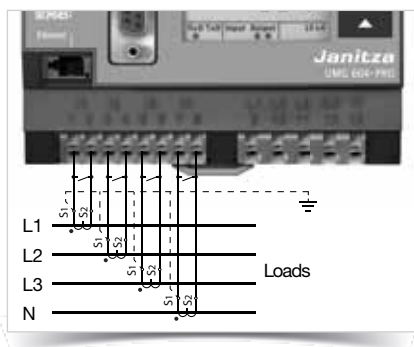


Fig.: Current measurement via current transformers

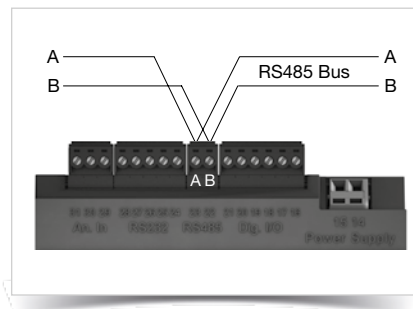


Fig.: RS485 interface, 2 pin plug contact



Fig.: Example temperature input (KTY83) and S0 pulse transducer

<b>General</b>	
Net weight	350 g (0.77 lb)
Device dimensions (W x H x D)	approx. 90 x 92 x 107,5 mm (3.54 x 3.62 x 4.23 in) (per DIN 43871:1992)
Housing flammability rating	UL 94V-0
Installation position	any
Fastening/assembly	35 mm DIN rail (as per IEC/EN60999-1, DIN EN 50022)
Battery	Type Lithium CR2032, 3 V (approval i.a.w. UL 1642)
Service life of the backlight (optional)	40000 h (50% of the initial brightness)

<b>Environmental conditions</b>	
The device is intended for weatherproof, fixed installation and meets the operational conditions in accordance with DIN IEC 60721-3-3.	
Working temperature range	-10 °C to +55 °C (14 °F. to 131 °F)
Relative humidity	5 to 95%, (at +25 °C/77 °F) without condensation
Pollution degree	2
Operating altitude	0 to 2000 m above sea level
Installation position	any
Ventilation	forced ventilation is not required.

<b>Transport and storage</b>	
The following information applies to devices which are transported or stored in the original packaging.	
Free fall	1 m
Temperature	-20 °C to +70 °C (-4 °F. to 158 °F)

<b>Supply voltage</b>	
The supply voltage must be connected through a UL/IEC approved fuse (6A Char. B) to the device.	
230 V option: Nominal range Operating range Power consumption Overvoltage category	95 V to 240 V (50/60 Hz) / DC 135 V to 340 V ±10% of nominal range max. 3.2 W / 9 VA 300 V CAT II
90 V option (without UL approval): Nominal range Operating range Power consumption Overvoltage category	50 V to 110 V (50/60 Hz) / DC 50 V to 155 V ±10% of nominal range max. 3.2 W / 9 VA 300 V CAT II
24 V option: Nominal range Operating range Power consumption Overvoltage category	20 V to 50 V (50/60 Hz) / DC 20 V to 70 V ±10% of nominal range max. 5 W / 8 VA 150 V CAT II

<b>Terminal connection capacity (supply voltage)</b>	
Connectable conductors. Only one conductor can be connected per terminal!	
Single core, multi-core, fine-stranded	0.08 - 2.5 mm <sup>2</sup> , AWG 28-12
Cable end sleeve (not insulated)	0.20 - 1.5 mm <sup>2</sup> , AWG 24-16
Cable end sleeve (insulated)	0.25 - 1.5 mm <sup>2</sup> , AWG 24-16
Stripping length	5-6 mm (0.2 - 0.24 in)

<b>Protection class</b>	
Protection class II in accordance with IEC 60536 (VDE 0106, part 1), i.e. a ground wire connection is not required!	
Protection against ingress of solid foreign bodies and water	IP20 in accordance with EN60529 September 2014, IEC60529:2013

Digital inputs	
Maximum counter frequency (Pulse input S0)	20 Hz
Switching input	
Input signal present	18 V to 28 V DC (typical 4 mA)
Input signal not present	0 to 5 V DC, current less than 0.5 mA
Response time (Jasic program)	200 ms
Cable length	up to 30 m unshielded, from 30 m shielded

Digital outputs	
2 digital outputs; semiconductor relays, not short-circuit proof	
Switching voltage	max. 60 V DC, 30 V AC
Switching current	max. 50 mAeff AC/DC
Response time (Jasic program)	200 ms
Output of voltage dips	20 ms
Output of voltage exceedance events	20 ms
Switching frequency	max. 20 Hz
Cable length	up to 30 m unshielded, from 30 m shielded

Terminal connection capacity	
Connectable conductors.	
Single core, multi-core, fine-stranded	0.20 - 1.5 mm <sup>2</sup> , AWG 24-16
Cable end sleeve (not insulated)	0.20 - 1.5 mm <sup>2</sup> , AWG 24-16
Cable end sleeve (insulated)	0.20 - 1.0 mm <sup>2</sup> , AWG 24-18
Tightening torque	0.20 - 0.25 Nm (1.77 - 2.21 lbf in)
Stripping length	7 mm (0.2756 in)

Temperature measurement input	
3-wire measurement	
Update time	Approx. 200 ms
Connectable sensors	PT100, PT1000, KTY83, KTY84
Total burden (sensor + cable)	max. 4 kOhm
Cable length	up to 30 m unshielded, from 30 m shielded

Sensor type	Temperature range	Resistor range	Measurement uncertainty
KTY83	-55 °C to +175 °C (-67 °F ..to 347 °F)	500 Ohm to 2.6 kOhm	± 1.5% rng <sup>1)</sup>
KTY84	-40 °C to +300 °C (-40 °F ..to 572 °F)	350 Ohm to 2.6 kOhm	± 1.5% rng <sup>1)</sup>
PT100	-99 °C to +500 °C (-146.2 °F ..to 932 °F)	60 Ohm to 180 Ohm	± 1.5% rng <sup>1)</sup>
PT1000	-99 °C to +500 °C (-146.2 °F ..to 932 °F)	600 Ohm to 1.8 kOhm	± 1.5% rng <sup>1)</sup>

<sup>1)</sup> rng = metering range

Terminal connection capacity (temperature measurement input)	
Single core, multi-core, fine-stranded	0.20 - 1.5 mm <sup>2</sup> , AWG 24-16
Cable end sleeve (not insulated)	0.20 - 1.5 mm <sup>2</sup> , AWG 24-16
Cable end sleeve (insulated)	0.20 - 1.0 mm <sup>2</sup> , AWG 24-18
Tightening torque	0.20 - 0.25 Nm (1.77 - 2.21 lbf in)
Stripping length	7 mm (0.2756 in)

<b>Voltage measurement inputs</b>	
Three-phase 4-conductor systems (L-N/L-L)	max. 277 V / 480 V
Three-phase 3-conductor systems (L-L)	max. 480 V
Resolution	0.01 V
Metering range L-N	0 <sup>1)</sup> to 600 V <sub>rms</sub>
Metering range L-L	0 <sup>1)</sup> to 1000 V <sub>rms</sub>
Crest factor	2 (related to 480 V <sub>rms</sub> )
Overvoltage category	300 V CAT III
Measurement voltage surge	4 kV
Protection of voltage measurement	1 - 10 A
Impedance	4 MOhm / phase
Power consumption	approx. 0.1 VA
Sampling rate	20 kHz / phase
Transients	> 50 μs
Frequency of the fundamental oscillation	45 Hz to 65 Hz
- Resolution	0.001 Hz

<sup>1)</sup>The UMG device can only determine measured values, if an L-N voltage of greater than 10 V<sub>eff</sub> or an L-L voltage of greater than 18 V<sub>eff</sub> is applied to at least one voltage measurement input.

<b>Terminal connection capacity (current measurement and voltage measurement)</b>	
Connectable conductors. Only one conductor can be connected per terminal!	
Single core, multi-core, fine-stranded	0.08 - 4.0 mm <sup>2</sup> , AWG 28-12
Cable end sleeve (not insulated)	0.25 - 2.5 mm <sup>2</sup> , AWG 24-14
Cable end sleeve (insulated)	0.25 - 2.5 mm <sup>2</sup> , AWG 24-14
Stripping length	8-9 mm (0.31 - 0.35 in)

<b>Current measurement inputs</b>	
Rated current	5 A
Rated current	6 A
Protection when measuring directly (without a current transformer)	6 A, char. B (approved i.a.w. UL/IEC)
Resolution on the display	10 mA
Metering range	0.005 to 7 A <sub>rms</sub>
Crest factor	2 (related to 6 A <sub>rms</sub> )
Overvoltage category	300 V CAT III
Measurement voltage surge	4 kV
Power consumption	approx. 0.2 VA (R <sub>i</sub> = 5 MOhm)
Overload for 1 sec.	100 A (sinusoidal)
Sampling rate	20 kHz

Phase angle accuracy of measurement	0.15°
-------------------------------------	-------

RS232 interface	
Connection	5-pin screw-type terminals
Protocol	Modbus RTU/slave
Transmission rate	9.6 kbps, 19.2 kbps, 38.4 kbps, 57.6 kbps, 115.2 kbps

RS485 interface	
Connection	2-pin screw-type terminals
Protocol	Modbus RTU/slave, Modbus RTU/master
Transmission rate	9.6 kbps, 19.2 kbps, 38.4 kbps, 57.6 kbps, 115.2 kbps, 921.6 kbps

Terminal connection capacity (RS 232 / RS 485)	
Single core, multi-core, fine-stranded	0.20 - 1.5 mm <sup>2</sup> , AWG 24-16
Cable end sleeve (not insulated)	0.20 - 1.5 mm <sup>2</sup> , AWG 24-16
Cable end sleeve (insulated)	0.20 - 1.0 mm <sup>2</sup> , AWG 24-18
Tightening torque	0.20 - 0.25 Nm (1.77 - 2.21 lbf in)
Stripping length	7 mm (0.2756 in)

Profibus interface (optional)	
Connection	SUB D 9-pole
Protocol	Profibus DP/V0 per EN 50170
Transmission rate	9.6 kBaud to 12 MBaud

Ethernet interface	
Connection	RJ45
Function	Modbus gateway, embedded web server (HTTP)
Protocols	TCP/IP, EMAIL (SMTP), DHCP client (BootP), Modbus/TCP(port 502), ICMP (ping), NTP,TFTP, Modbus RTU over Ethernet (port 8000), FTP SNMP.

Measurement uncertainty		
Measurement uncertainty on the device applies when using the following metering ranges. The measured value must be within the specified limits. The measurement uncertainty is not specified outside of these limits.		
Measured value	Measurement uncertainties	
Voltage	± 0.2%	as per DIN EN 61557-12:2008
Current L	± 0.25%	in accordance with DIN EN 61557-12:2008
Current N	± 1%	as per DIN EN 61557-12:2008
Power	± 0.4%	as per DIN EN 61557-12:2008
Harmonics U, I	Class 1, DIN EN 61000-4-7	
Active energy		
Current transformer ..5 A	Class 0.5S	(DIN EN62053-22:2003, IEC62053:22:2003)
Current transformer ../1 A	Class 1	(DIN EN62053-21:2003, IEC62053:21:2003)
Reactive energy		
Current transformer ..5 A	Class 2	(DIN EN62053-23:2003, IEC62053:23:2003)
Current transformer ../1 A	Class 2	(DIN EN62053-23:2003, IEC62053:23:2003)
Frequency	± 0.01 Hz	
Internal clock	±1 minute/month (18° C to 28° C) (64,4 °F ..to 82,4 °F)	

Firmware	
Firmware update	Please observe the operating instructions

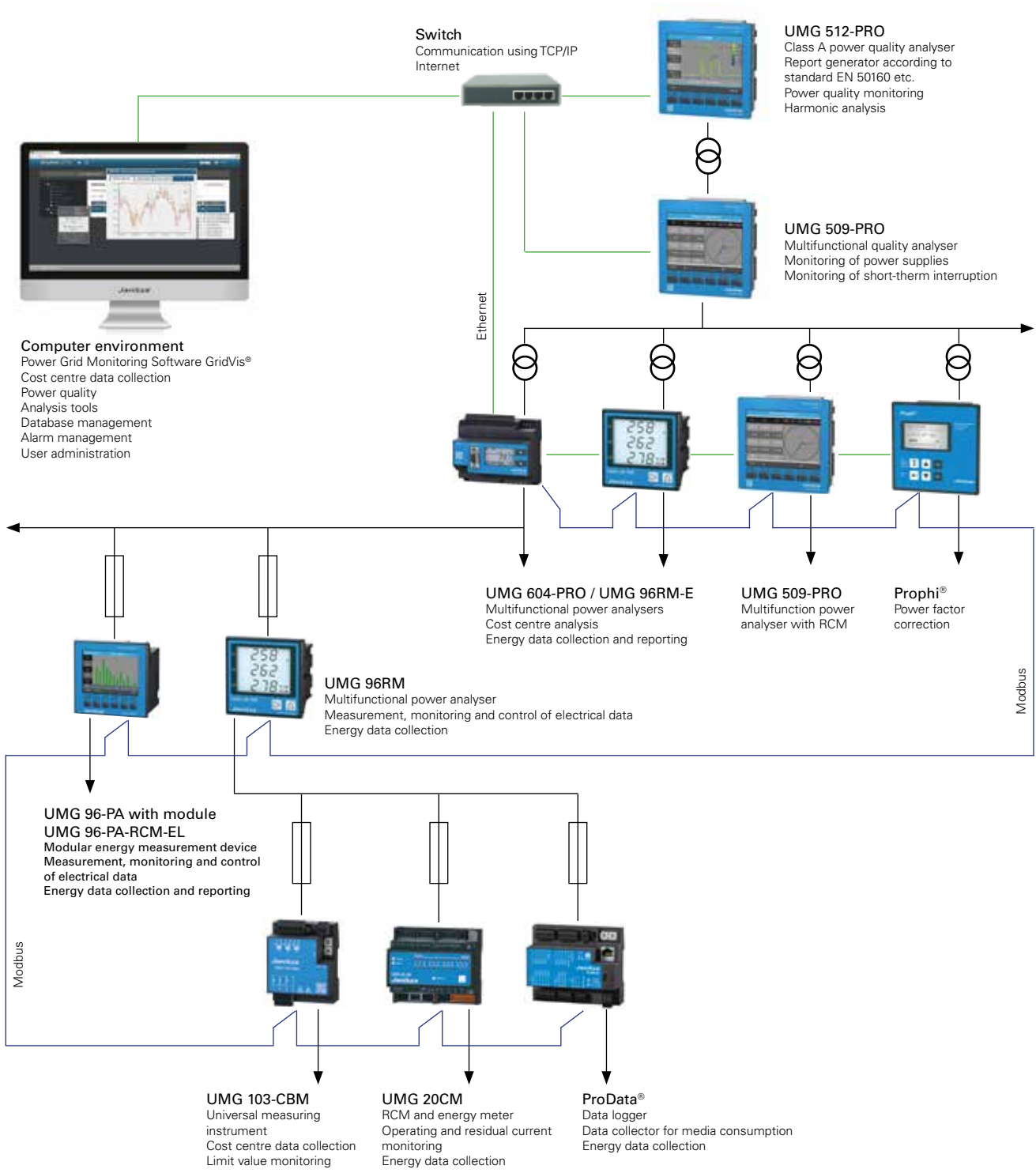
Comment: For detailed technical information please refer to the operation manual and the Modbus address list.

The specification applies under the following conditions:

- annual re-calibration,
- a warm-up time of 10 minutes,
- an ambient temperature of 18 to 28° C (64,4 °F ..to 82,4 °F).

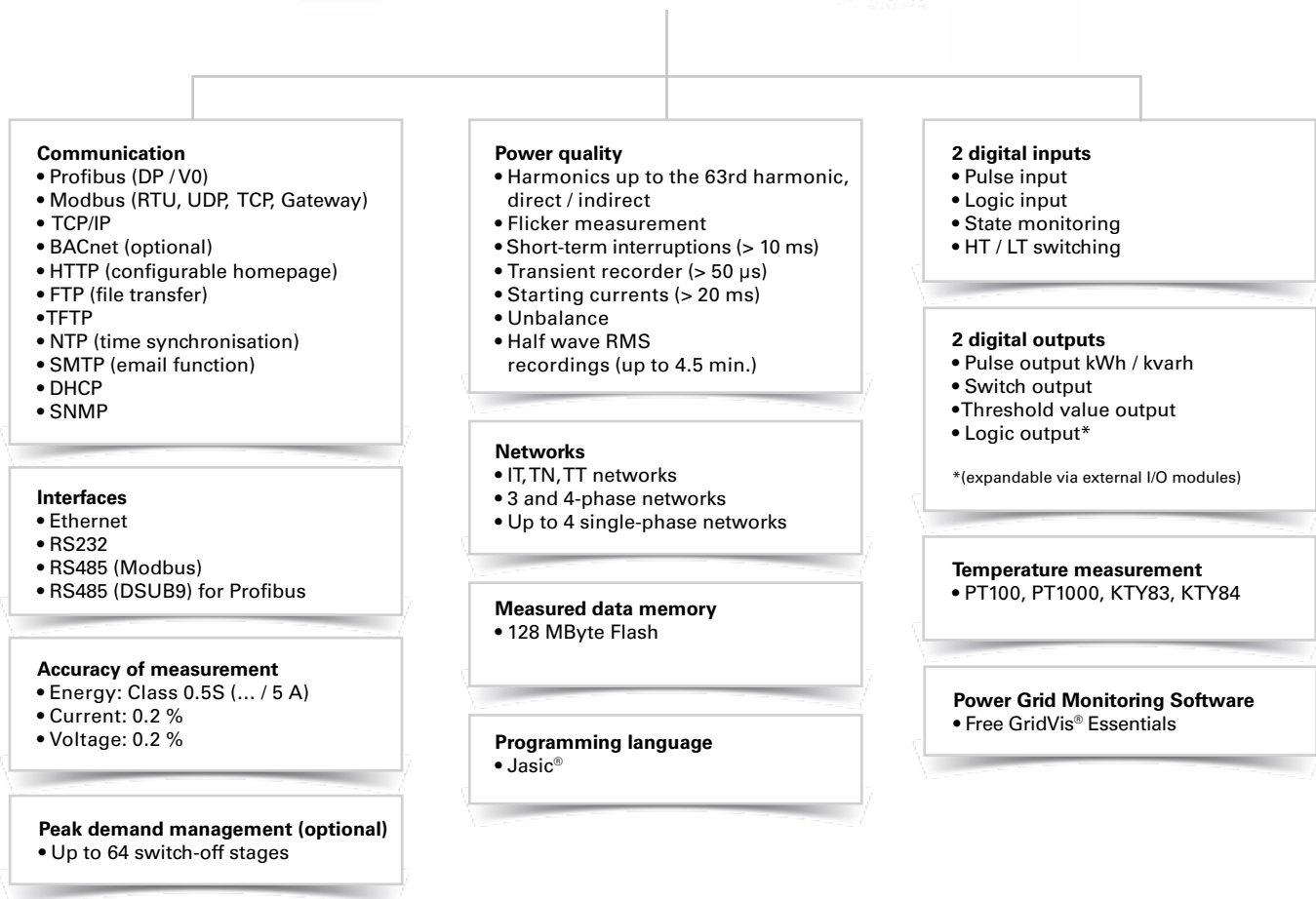
If the device is operated outside the range of 18 to 28° C (64,4 °F ..to 82,4 °F), an additional measuring error of ±0.01% of the measured value per °C deviation must be taken into account.

**Chapter 02**  
**UMG 604-PRO**



# UMG 605-PRO

## Power quality analyzer



## Areas of application



- Power quality monitoring
- Ethernet gateway for subordinate measurement points
- Analysis of electrical disturbances in the event of network problems
- Report generator for various power quality standards
- Control tasks e.g. depending on measured value or limit values being reached
- Measured value transducer for building management systems or PLC



## Main features



### Power quality

- Continuous power quality monitoring (e.g. EN 50160)
- Harmonics analysis up to the 63rd harmonic, even and odd
- Interharmonics
- Distortion factor THD-U / THD-I
- Measurement of positive, negative and zero sequence component
- Flicker measurement in accordance with DIN EN 61000-4-15
- Logging and storage of transients ( $> 50 \mu\text{s}$ )
- Recording of short-term interruptions ( $> 10 \text{ ms}$ )
- Monitoring start-up processes
- Recorder for limit value events

### Power

- 4 voltage and 4 current measurement inputs
- Logging and digitalisation of effective values (true RMS) of currents and voltages (15 – 440 Hz)
- Continuous sampling of the voltage and current measurement inputs at 20 kHz
- Recording of over 2,000 measured values per measurement cycle (200 ms)
- Stipulation of nominal current possible for measuring current events
- Fourth current measurement input is suitable for measuring the current in the neutral or PE conductor or for measuring any potential difference between N and PE.
- Large measured data memory (memory range = 5 000 000 measured values)
- Simple remote polling of measured data via the device's own homepage
- All interfaces can be used simultaneously
- Up to 4 ports can be accessed simultaneously

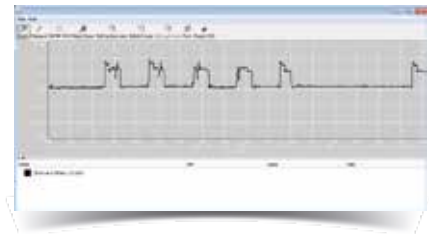


Fig.: GridVis®- Flicker Monitoring



Fig.: Alarm management, alarm list (logbook)

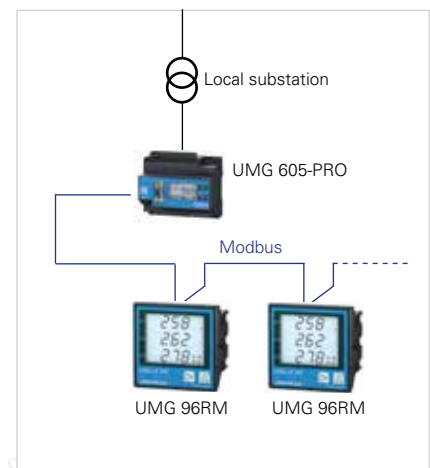


Fig.: Example of a master - slave combination





### Impressive reporting with GridVis®

- Automatic generation and sending of power quality reports
- Power quality reports per EN 50160, EN 61000-2-4, IEEE519
- Illustration of the ITI-(CBEMA) curve
- Freely definable time planning for the generation of reports



### Modern communications architecture via Ethernet

- Rapid, cost-optimised and reliable communication through integration into an existing Ethernet architecture
- Integration in PLC systems and building management systems
- High flexibility due to the use of open standards
- Simultaneous polling of interfaces possible



### Ethernet-Modbus gateway

- Simple integration of Modbus-RTU devices into an Ethernet architecture through the Modbus gateway function
- Integration of devices with identical file formats and matching function codes possible via Modbus RTU interface



### Powerful alarm management

- Can be programmed via the graphic programming or Jasic® source code
- All measured values can be used
- Can be arbitrarily, mathematically processed
- Individual forwarding via email sending, switching of digital outputs, writing to Modbus addresses etc.
- Watchdog APP
- Further alarm management functions via GridVis®-Service alarm management



Fig.: Automatic reporting

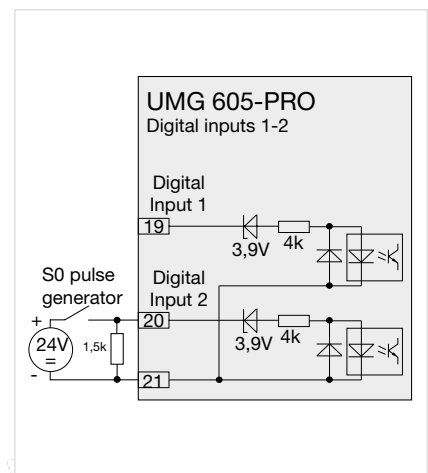


Fig.: Example for the connection of an S0 pulse transducer to digital input 2

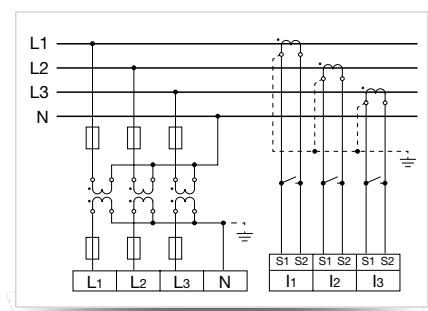


Fig.: Measurement via 3 voltage transformers in a three-phase 4-wire network with asymmetric loading



**High-speed Modbus**

- Fast and reliable data exchange via RS485 interface
- Speed up to 921.6 kB/s



**Graphical programming**

- Comprehensive programming options on the device, 7 programs simultaneously (PLC functionality)
- Jasic® source code programming
- Functional expansions far beyond pure measurement
- Complete APPs from the Janitza library



**Convenient home page and email functions**

- Information can be received conveniently by email and via the device homepage
- Access to powerful device homepage via web browser
- Online data, historical data, graphs, events and much more, is available direct from the homepage



**Large measurement data memory**

- 128 MByte
- 5,000,000 saved values
- Recording range up to 2 years
- Recording freely configurable by the user

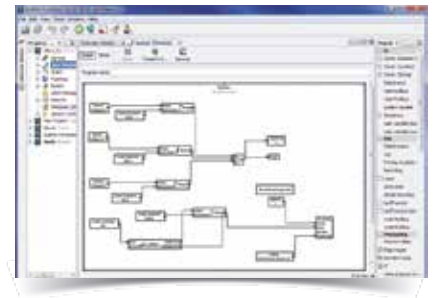


Fig.: Graphical programming



Fig.: Illustration of the online data via the device's own homepage



Fig.: Large measurement data memory

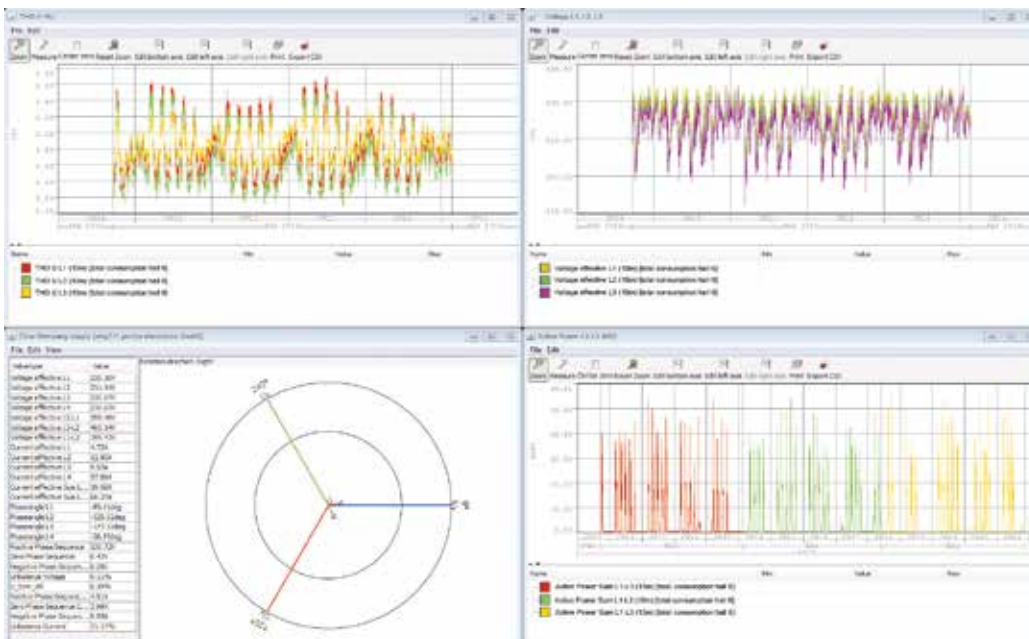
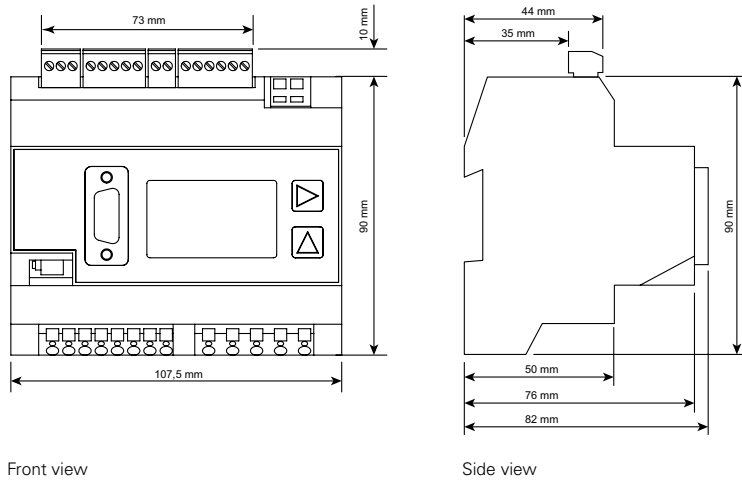


Fig.: GridVis® graphset with THD-U, voltage, phasor diagram and load profile (kW)



## Dimension diagrams

All dimensions in mm

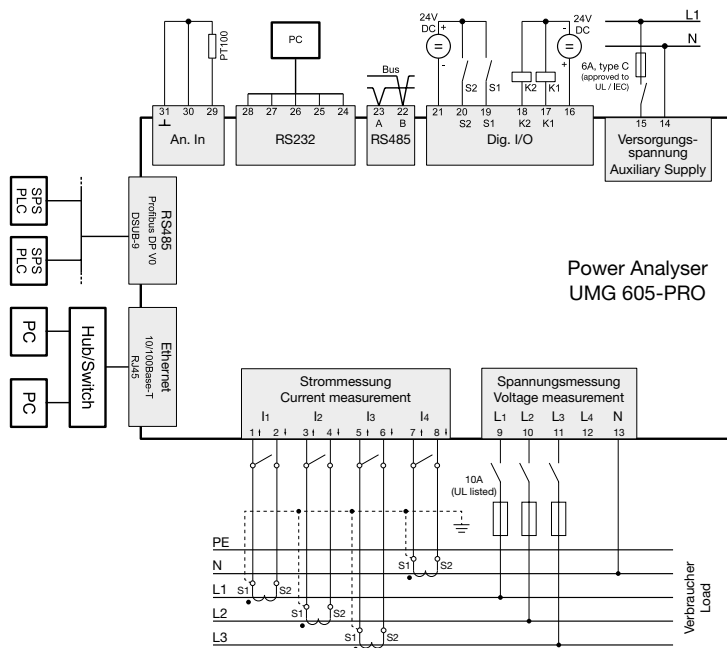


Front view

Side view



## Typical connection





## Device overview and technical data

	UMG 605-PRO		
Item number	52.16.028		
Item number (UL)	52.16.227	-	52.16.229
AC supply voltage	95 to 240 V AC	50 to 110 V AC	20 to 50 V AC
Supply voltage DC	135 to 340 V DC	50 to 155 V DC	20 to 70 V DC
<b>Device options</b>			
BACnet communication	<b>52.16.083</b>	<b>52.16.083</b>	<b>52.16.083</b>

General	
Net weight	350 g (0.77 lb)
Device dimensions (W x H x D)	approx. 90 x 82 x 107.5 mm (3.54 x 3.23 x 4.23 in) (per DIN 43871:1992)
Housing flammability rating	UL 94V-0
Installation position	any
Fastening/assembly	35 mm DIN rail (as per IEC/EN60999-1, DIN EN 50022)
Battery	Type Lithium CR2032, 3 V

Environmental conditions	
The device is intended for weatherproof, fixed installation and meets the operational conditions in accordance with DIN IEC 60721-3-3.	
Working temperature range	-10 °C to +55 °C (14 °F ..to 131 °F)
Relative humidity	5 to 95%, (at +25 °C/77 °F) without condensation
Pollution degree	2
Operating altitude	0 to 2000 m above sea level
Installation position	any
Ventilation	forced ventilation is not required.

Transport and storage	
The following information applies to equipment transported in its original packaging or	
Free fall	1 m
Temperature	-20 °C to +70 °C (-4 °F to 158 °F)

Supply voltage	
The supply voltage must be connected through a UL/IEC approved fuse (6A Char. B) to the	
230 V option: • Nominal range • Operating range • Power consumption • Overvoltage category	95 V to 240 V (50/60 Hz) / DC 135 V to 340 V ±10% of nominal range max. 3.2 W / 9 VA 300 V CAT II
90 V option (without UL approval): • Nominal range • Operating range • Power consumption • Overvoltage category	50 V to 110 V (50/60 Hz) / DC 50 V to 155 V ±10% of nominal range max. 3.2 W / 9 VA 300 V CAT II
24 V option: • Nominal range • Operating range • Power consumption • Overvoltage category	20 V to 50 V (50/60 Hz) / DC 20 V to 70 V ±10% of nominal range max. 5 W / 8 VA 150 V CAT II

Terminal connection capacity (supply voltage)	
Connectable conductors. Only one conductor can be connected per terminal!	
Single core, multi-core, fine-stranded	0.08 - 2.5 mm <sup>2</sup> , AWG 28 - 12
Terminal pins, core end sheath	1.5 mm <sup>2</sup> , AWG 16

<b>Protection class</b>	
Protection class II in accordance with IEC 60536 (VDE 0106, part 1), i.e. a ground wire connection is not required!	
Protection against ingress of solid foreign bodies and water	IP20 in accordance with EN60529 September 2014, IEC60529:2013

<b>Digital inputs</b>	
(Pulse input S0)	
Maximum counter frequency	20 Hz
Switching input	
Input signal present	18 V to 28 V DC (typical 4 mA)
Input signal not present	0 to 5 V DC, current less than 0.5 mA
Response time (Jasic program)	200 ms
Cable length	up to 30 m unshielded, from 30 m shielded

<b>Digital outputs</b>	
2 digital outputs; semiconductor relays, not short-circuit proof	
Switching voltage	max. 60 V DC, 30 V AC
Switching current	max. 50 mAeff AC/DC
Response time (Jasic program)	200 ms
Output of voltage dips	20 ms
Output of voltage exceedance events	20 ms
Switching frequency	max. 20 Hz
Cable length	up to 30 m unshielded; from 30 m shielded

<b>Connectable conductors</b>	
Single core, multi-core, fine-stranded	0.08 - 1.5 mm <sup>2</sup>
Terminal pins, core end sheath	1 mm <sup>2</sup> , only one conductor must be connected per terminal!

<b>Temperature measurement input</b>	
Update time	Approx. 200 ms
Connectable sensors	PT100, PT1000, KTY83, KTY84
Total burden (sensor + cable)	max. 4 kOhm
Cable length	up to 30 m unshielded, from 30 m shielded

Sensor type	Temperature range	Resistor range	Measurement uncertainty
KTY83	-55 °C to +175 °C (-67 °F ..to 347 °F)	500 Ohm to 2.6 kOhm	± 1.5% rng <sup>1)</sup>
KTY84	-40 °C to +300 °C (-40 °F ..to 572 °F)	350 Ohm to 2.6 kOhm	± 1.5% rng <sup>1)</sup>
PT100	-99 °C to +500 °C (-146.2 °F ..to 932 °F)	60 Ohm to 180 Ohm	± 1.5% rng <sup>1)</sup>
PT1000	-99 °C to +500 °C (-146.2 °F ..to 932 °F)	600 Ohm to 1.8 kOhm	± 1.5% rng <sup>1)</sup>

<sup>1)</sup> rng = metering range

<b>Connectable conductors</b>	
Single core, multi-core, fine-stranded	0.08 - 1.5mm <sup>2</sup>
Terminal pins, core end sheath	1 mm <sup>2</sup> , only one conductor must be connected per terminal!

<b>RS232 interface</b>	
Connection	5-pin screw-type terminals
Protocol	Modbus RTU/slave
Transmission rate	9.6 kbps, 19.2 kbps, 38.4 kbps, 57.6 kbps, 115.2 kbps

<b>RS485 interface</b>	
Connection	2-pin screw-type terminals
Protocol	Modbus RTU/slave, Modbus RTU/master
Transmission rate	9.6 kbps, 19.2 kbps, 38.4 kbps, 57.6 kbps, 115.2 kbps, 921.6 kbps

<b>Profibus interface</b>	
Connection	SUB D 9-pole
Protocol	Profibus DP/V0 per EN 50170
Transmission rate	9.6 kBaud to 12 MBaud

<b>Ethernet interface</b>	
Connection	RJ45
Function	Modbus gateway, embedded web server (HTTP)
Protocols	TCP/IP, EMAIL (SMTP), DHCP client (BootP), Modbus/TCP(port 502), ICMP (ping), NTP,TFTP, Modbus RTU over Ethernet (port 8000), FTP SNMP.

<b>Voltage measurement inputs</b>	
Three-phase 4-conductor systems (L-N/L-L)	max. 277 V / 480 V
Three-phase 3-conductor systems (L-L)	max. 480 V
Resolution	0.01 V
Crest factor	2 (related to 480 V <sub>rms</sub> )
Overvoltage category	300 V CAT III
Measurement voltage surge	4 kV
Protection of voltage measurement	1 - 10 A
Impedance	4 MOhm / phase
Power consumption	approx. 0.1 VA
Sampling rate	20 kHz / phase
Transients	> 50 µs
Frequency of the fundamental oscillation	15 Hz to 440 Hz
- Resolution	0.001 Hz

<b>Current measurement inputs</b>	
Rated current	5 A
Rated current	6 A
Protection when measuring directly (without a current transformer)	6 A, char. B (approved i.a.w. UL/IEC)
Resolution on the display	10 mA
Crest factor	2 (related to 6 A <sub>rms</sub> )
Overvoltage category	300 V CAT III
Measurement voltage surge	4 kV
Power consumption	approx. 0.2 VA (Ri = 5 MOhm)
Overload for 1 sec.	100 A (sinusoidal)
Sampling rate	20 kHz

Phase angle accuracy of measurement	0.15 °
-------------------------------------	--------

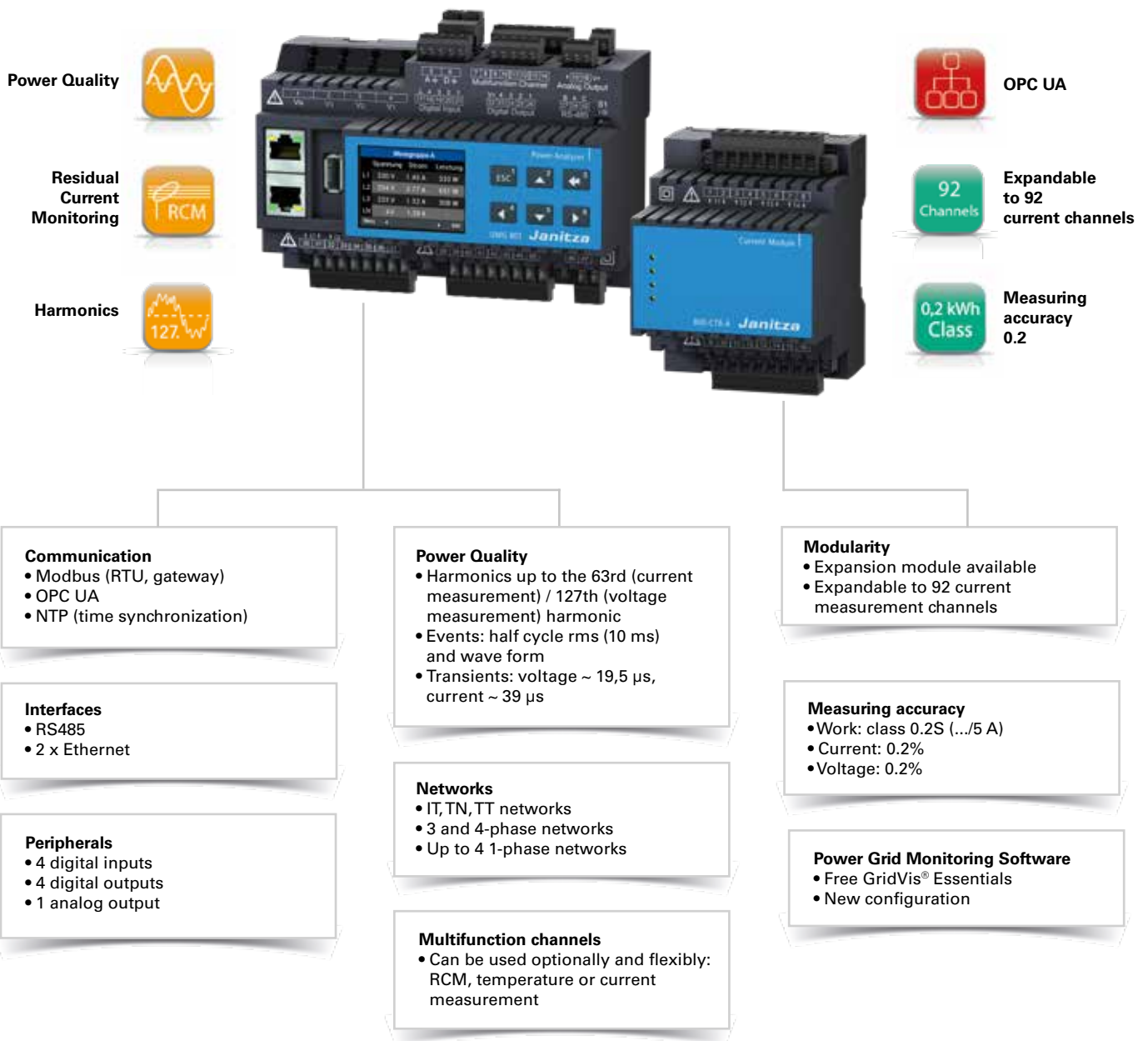
<b>Terminal connection capacity (current measurement and voltage measurement)</b>	
Connectable conductors. Only one conductor can be connected per terminal!	
Single core, multi-core, fine-stranded	0.08 - 4 mm <sup>2</sup> , AWG 28 - 12
Terminal pins, core end sheath	2.5 mm <sup>2</sup> , AWG 14

<b>Firmware</b>	
Firmware update	Please observe the operating instructions

Comment: For detailed technical information please refer to the operation manual and the Modbus address list.

# UMG 801

Modular energy measurement device for the DIN rail





## Areas of application

- Industrial sector
- Data centers
- Commercial buildings
- Building installations on distribution units, circuit breakers and busbar trunking systems
- Energy supplier
- Continuous monitoring of Power Quality (PQ)
- Harmonic analysis at grid anomalies

## Main features



### Power Quality

- Harmonics analysis up to the 127th harmonic
- Unbalance
- Distortion factor THD-U, THD-I
- Measurement of co-system, counter and zero sequence component
- Events: half cycle rms (10 ms) and wave form
- Transients: voltage ~ 19,5  $\mu$ s, current ~ 39  $\mu$ s
- Standardized data format PQ Diff and Comtrade usable in parallel



### Communication

- Fast, cost-optimized and reliable communication through connection to an existing Ethernet system
- Integration in PLC systems and GLT
- High flexibility through the use of open standards
- Simultaneous query of the interfaces possible
- Configuration of the entire measuring system via OPC UA
- Easy integration of measurement data from the base unit and measurement modules into higher-level systems (e.g. building management systems, SCADA systems)
- Cyber security: Integrated security mechanisms to protect against unauthorized access and misuse
- Future-proof software architecture as the OPC UA standard evolves with new applications





### Ethernet Modbus gateway

- Easy integration of the Modbus RTU devices in the Ethernet system through the Modbus gateway function
- Integration of devices with identical file formats and consistent function codes possible via the Modbus RTU interface



### Measurement device with accuracy of 0.2% (V), kWh class = 0.5S

- High sampling rate at 25.6 kHz / 51.2 kHz (current/voltage)
- Reliable measuring accuracy of 0.2% (V)
- Energy class (kWh): 0.2S



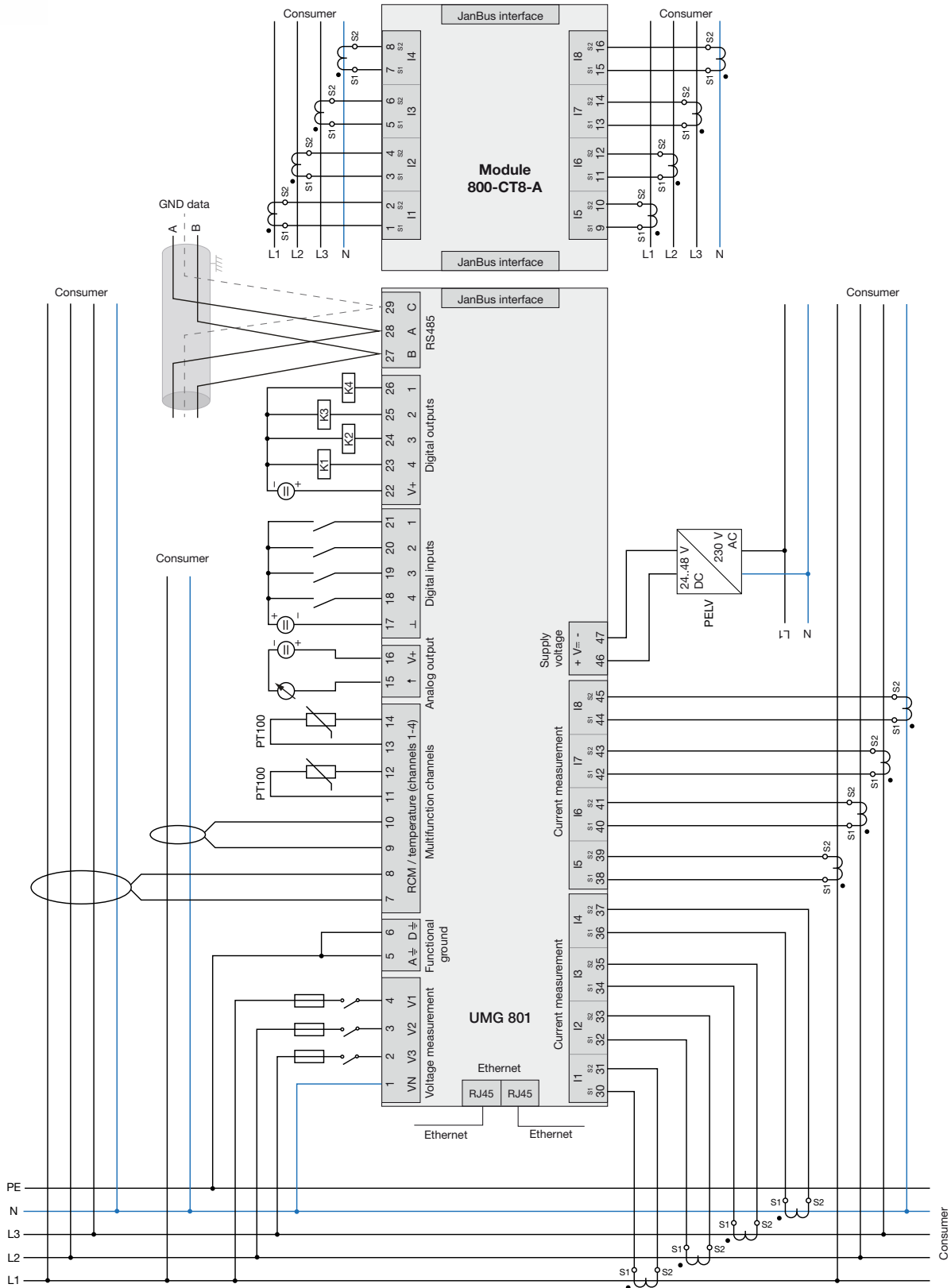
### Modular system expansion

- Easy system expansion due to flexible scaling to 92 current measurement channels
- Up to 10 current measurement modules can be integrated via click system, without external cabling between the basic device and the current measurement modules
- Space optimization through compact design, even with measurement point extension
- No additional power supply required for the measuring modules
- Costs savings through shortened assembly times
- Reduced error sources thanks to Plug & Play solution
- Low costs per additional measurement channel
- No additional voltage measurement necessary
- Measurement distance can be bridged up to a total length of 100 m
- The GridVis® Essentials Power Grid Monitoring Software provides comprehensive options for data preparation, visualization and documentation





# Typical connection variant

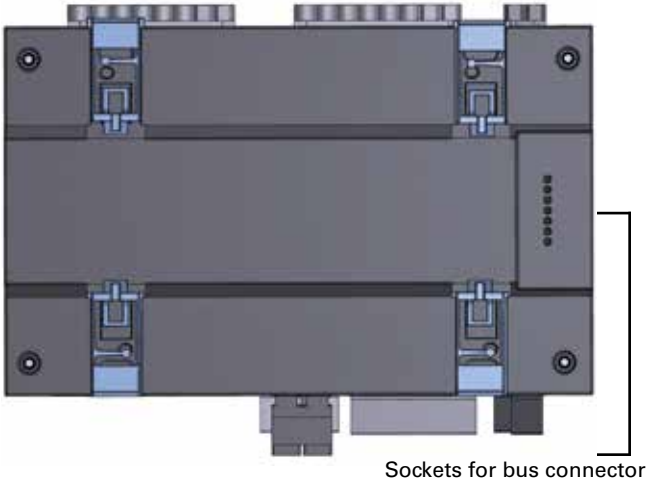




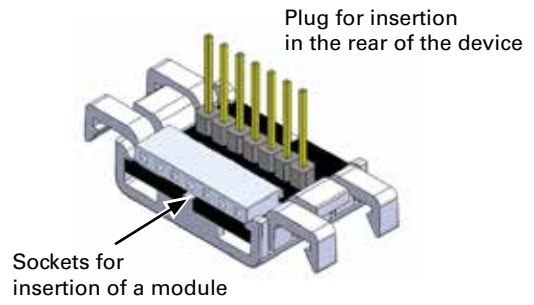
# Dimensional drawings

All specifications in mm

Rear view



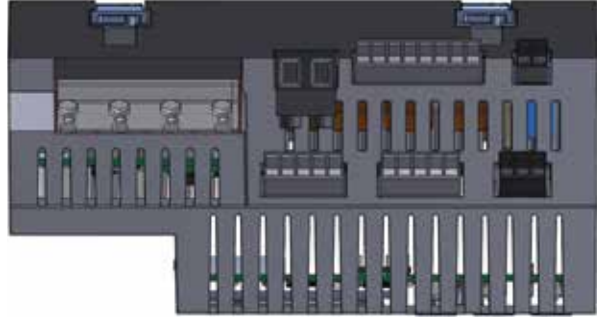
Bus connector



View from below



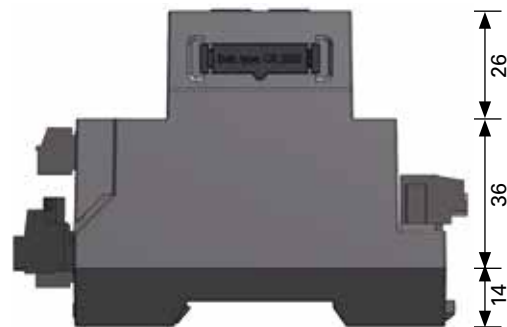
View from above



Front view



View from the left





## Device overview and technical data

UMG 801 <sup>1)</sup>	
Item number	52.31.001
Supply voltage	External 24 ... 48 VDC, PELV

General	
Net weight	420 g (0.93 lb)
Device dimensions (W x H x D)	approx. 144 x 90 x 76 mm (5.67 x 3.54 x 2.99 in)
Battery	Type: Lithium CR2032, 3 V (UL1642 approval)
Integrated memory	4 GB
Backlight service life	40000 h (50% of the start brightness)
Mounting orientation	As desired
Fastening/mounting – suitable DIN rails – 35 mm (1.38 in)	TS 35/7.5 according to EN 60715 TS 35/10 TS 35/15 x 1.5
Impact resistance	IK07 according to IEC 62262

Transport and storage	
The following information apply to devices which are transported and stored in the original packaging.	
Free fall	1 m (39.37 in)
Temperature	-25 °C bis +70 °C (-13 °F ..to 158 °F)
Relative humidity	5 to 95% RH at 25 °C (77 °F) no condensation

Environmental conditions during operation	
The device <ul style="list-style-type: none"> <li>• For weather-protected and stationary use.</li> <li>• Fulfills operating conditions according to DIN IEC 60721-3-3.</li> <li>• Has protection class II according to IEC 60536 (VDE 0106, part 1), a ground wire connection is not required!</li> </ul>	
Rated temperature range	-10 °C bis +55 °C (14 °F to 131 °F)
Relative humidity	5 to 95% at 25 °C (77 °F) no condensation
Operating height/overvoltage category	2000 m (6562 ft) above sea level Voltage measurement: 1000 V CAT III; 600 V CAT IV Current measurement: 300 V CAT II
	4000 m (13123 ft) above sea level Voltage measurement: 600 V CATIII; Current measurement: 300 V CATII
Pollution degree	2
Ventilation	No forced ventilation required
Protection against foreign matter and water	IP20 according to EN60529

Supply voltage	
Nominal range	DC: 24 V – 48 V, PELV
Operating range	± 10% of nominal range
Power consumption	max. 4 W
Maximum power consumption with 10 modules	12 W (UMG 801 with 4 W plus 10 modules with 0.8 W each)
Recommended overcurrent protection device for the line protection	2–6 A (char. B), IEC-/UL approval

1) Separate switching power supply is required, optionally available:  
switching power supply ultraslim, item no. 16.05.012 or  
switching power supply with step shape/DIN rail, item no. 16.05.014

Voltage measurement	
3-phase 4-conductor systems with rated voltages up to	480 V <sub>LN</sub> / 830 V <sub>LL</sub> (± 10%) according to IEC 347 V <sub>LN</sub> / 600 V <sub>LL</sub> (± 10%) according to UL
3-phase 3-conductor systems (grounded) with rated voltages up to	830 V <sub>L-L</sub> (± 10%) according to IEC 600 V <sub>L-L</sub> (± 10%) according to UL
3-phase 3-conductor systems (non-grounded) with rated voltages up to	690 V <sub>L-L</sub> (± 10%) according to IEC 600 V <sub>L-L</sub> (± 10%) according to UL
Overvoltage category	· 1000 V CAT III according to IEC · 600 V CAT III according to UL
Rated surge voltage	8 kV
Protection of the voltage measurement	1–10 A tripping characteristic B (with IEC/UL approval)
Measuring range L-N	0 <sup>1)</sup> ... 720 V <sub>eff</sub> (max. overvoltage 1000 V <sub>eff</sub> )
Measuring range L-L	0 <sup>1)</sup> ... 1000 V <sub>eff</sub> (max. overvoltage 1000 V <sub>eff</sub> )
Measuring range N-PE	up to 100 V
Resolution	16 bit
Crest factor	1.6 (referred to measuring range 600 V L-N)
Impedance	4 MΩ/phase
Power consumption	approx. 0.1 VA
Sampling frequency	51.2 kHz
Frequency of fundamental oscillation	40 Hz ... 70 Hz
- Resolution	0.01 Hz
Harmonics	1 ... 127.

1) ... The device only measures if at least one voltage measurement input has an L-N voltage of >10 V<sub>eff</sub> or an L-L voltage of >18 V<sub>eff</sub> present.

Current measurement (../1 A) (../5 A)	
Nominal current	5 A
Channels	8 · 2 systems – L1, L2, L3, N (optional) · Single channels
Measuring range	0.005 ... 6 A <sub>eff</sub>
Crest factor (based on the rated current)	1.98
Overload for 1 sec.	120 A (sinusoidal)
Resolution	0.1 mA (color graphic display 0.01A)
Overvoltage category	300 V CAT II
Rated surge voltage	2.5 kV
Power consumption	approx. 0.2 VA (R <sub>i</sub> = 5 mΩ)
Sampling frequency	25.6 kHz
Harmonics	1 ... 63.

The device optionally has 4 multifunction channels for use as

- Residual current measuring inputs and/or temperature measuring inputs (mixed),
- Additional system inputs (L1, L2, L3; N)

<b>Residual current monitoring (RCM)</b>	
Nominal current	30 mA <sub>Eff</sub>
Measurement range	0 ... 40 mA <sub>Eff</sub>
Operating current	50 µA
Resolution	1 µA (color graphic display 0.01 A)
Crest factor	1.414 (relative to 80 mA)
Load	4 Ω
Overload for 20 ms	50 A
Overload for 1 s	5 A
Permanent overload	1 A
Standard	IEC/TR 60755 (2008-01), type A + type B and B+ (via corresponding current transformer)

<b>Temperature measurement</b>	
Update time	1 s
Total burden (sensor and lead)	max. 4 kΩ
Cable	Up to 30 m (32.81 yd) not shielded Greater than 30 m (32.81 yd) shielded
Suitable sensor types	KTY83, KTY84, PT100, PT1000

<b>Digital inputs</b> 4 digital inputs, solid state relays, not short-circuit proof.	
Maximum counter frequency	20 Hz
Input signal applied	18 ... 28 V DC (typically 4 mA)
Input signal not applied	0 ... 5 V DC, current less than 0.5 mA

<b>Digital outputs</b> 4 digital outputs, semiconductor relays, not short-circuit proof.	
Switching voltage	max. 60 V DC
Switching current	max. 50 mA <sub>Eff</sub> DC
Response time	approx. 500 ms
Digital output (energy pulses)	max. 20 Hz

<b>Cable length (digital inputs/outputs)</b>	
Up to 30 m (32.81 yd)	Unshielded
Greater than 30 m (32.81 yd)	Shielded

<b>Analog output</b> 1 channel	
External supply	max. 33 V DC
Current	0/4...20 mA DC
Update time	0.2 s
Load	max. 300 Ω
Resolution	10 Bit

<b>RS485 interface</b> 3-conductor connection with A, B, GND	
Protocol	Modbus RTU/Slave Modbus RTU/Gateway
Transmission rate	9.6 kbps, 19.2 kbps, 38.4 kbps, 57.6 kbps, 115.2 kbps
Termination	DIP switches

<b>Ethernet interfaces</b>	
Connection	2 x RJ45
Function	Modbus gateway
Protocols, services and time synchronization	OPC UA, DHCP, Modbus/TCP, NTP

<b>Connecting capacity of the terminals (supply voltage)</b>	
Connectible conductors. Only connect one conductor per terminal point!	
Single core, multi-core, fine-stranded	0.2 – 2,5 mm <sup>2</sup> , AWG 26-12
Wire ferrules (non-insulated) – Recommended stripping length	0.2 – 2,5 mm <sup>2</sup> , AWG 26-12 – 10 mm (0.3937 in)
Wire ferrules (insulated) – Recommended stripping length	0.2 – 2.5 mm <sup>2</sup> , AWG 26-12 – 13 mm (0.5118 in)
Wire ferrules: Length of the contact sleeve	10 mm (0.3937 in)

<b>Connecting capacity of the terminals (current measurement)</b>	
Connectible conductors. Only connect one conductor per terminal point!	
Single core, multi-core, fine-stranded	0.2 – 2,5 mm <sup>2</sup> , AWG 26-12
Wire ferrules (non-insulated) – Recommended stripping length	0.2 – 2,5 mm <sup>2</sup> , AWG 26-12 – 10 mm (0.3937 in)
Wire ferrules (insulated) – Recommended stripping length	0.2 – 2.5 mm <sup>2</sup> , AWG 26-12 – 13 mm (0.5118 in)
Screw flange tightening torque	0.4 – 0.5 Nm (3.54 - 4.43 lbf in)
Wire ferrules: Length of the contact sleeve	10 mm (0.3937 in)

<b>Connecting capacity of the terminals (voltage measurement)</b>	
Connectible conductors. Only connect one conductor per terminal point!	
Single core, multi-core, fine-stranded	0.08 – 4.0 mm <sup>2</sup> , AWG 28-12
Wire ferrules (insulated/non-insulated)	0.25 – 2.5 mm <sup>2</sup> , AWG 24-14
Strip length	8 – 9 mm (0.3150 - 0.3543 in)

<b>Connecting capacity of the terminals (functional earth A/D)</b>	
Connectible conductors. Only connect one conductor per terminal point!	
Single core, multi-core, fine-stranded	0.2 – 4.0 mm <sup>2</sup> , AWG 24-12
Wire ferrules (non-insulated)	0.2 – 4.0 mm <sup>2</sup> , AWG 24-12
Wire ferrules (insulated)	0.2 – 2.5 mm <sup>2</sup> , AWG 26-14
Tightening torque	0.4 – 0.5 Nm (3.54 - 4.43 lbf in)
Strip length	7 mm (0.2756 in)

<b>Connecting capacity of the terminals - Multifunction channels (RCM, Temp.)</b>	
Connectible conductors. Only connect one conductor per terminal point!	
Single core, multi-core, fine-stranded	0.2 – 1.5 mm <sup>2</sup> , AWG 24-16
Wire ferrules (non-insulated)	0.2 – 1.5 mm <sup>2</sup> , AWG 26-16
Wire ferrules (insulated)	0.2 – 1 mm <sup>2</sup> , AWG 26-18
Tightening torque	0.2 – 0.25 Nm (1.77 - 2.21 lbf in)
Strip length	7 mm (0.2756 in)

<b>Connecting capacity of the terminals (digital inputs/outputs, analog output)</b>	
Single core, multi-core, fine-stranded	0.2 – 1.5 mm <sup>2</sup> , AWG 24-16
Wire ferrules (non-insulated)	0.2 – 1.5 mm <sup>2</sup> , AWG 26-16
Wire ferrules (insulated)	0.2 – 1 mm <sup>2</sup> , AWG 26-18
Tightening torque	0.2 – 0.25 Nm (1.77 - 2.21 lbf in)
Strip length	7 mm (0.2756 in)

<b>Connecting capacity of the terminals (RS485)</b>	
Single core, multi-core, fine-stranded	0.2 – 1.5 mm <sup>2</sup> , AWG 24-16
Wire ferrules (non-insulated)	0.2 – 1.5 mm <sup>2</sup> , AWG 26-16
Wire ferrules (insulated)	0.2 – 1 mm <sup>2</sup> , AWG 26-18
Tightening torque	0.2 – 0.25 Nm (1.77 - 2.21 lbf in)
Strip length	7 mm (0.2756 in)

<b>Firmware</b>	
Firmware update	Please observe the operating instructions

Remark: For detailed technical information, please refer to the operation manual and Modbus address list.

**Potential isolation and electrical safety of the interfaces**

The interfaces (RS-485, Ethernet) have:

- Double insulation to the inputs of the voltage and current measurement.
- Functional insulation relative to each other, to the supply voltage, to the measuring inputs for residual current and temperature, to the digital inputs/outputs and to the analog output.

The interfaces of the connected devices require double or reinforced insulation against mains voltages (according to IEC 61010-1: 2010).

**Potential isolation and electrical safety of the multifunction channels (RCM, Temp.)**

The inputs of the multifunction channels have:

- Double insulation to the inputs of the voltage and current measurement.
- No insulation to each other or to the supply voltage.
- Functional isolation to the Ethernet, RS-485 interfaces, to the digital inputs/outputs and to the analog output.

External sensors and/or transformers require double insulation relative to system components with dangerous touch voltages (according to IEC61010-1:2010).

**Potential isolation and electrical safety of the digital inputs and outputs (I/Os) and the analog output**

The digital inputs and outputs as well as the analog output are equipped with:

- Double insulation to the inputs of the voltage and current measurement.
- Functional isolation relative to each other, to the supply voltage, to the Ethernet, RS-485 and multifunction channel interfaces.





## Module 800-CT8-A technical data



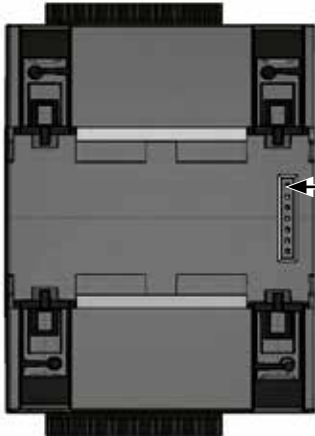
Module 800-CT8-A	
Item number	52.31.201
<b>General</b>	
Net weight	Approx. 220 g (0.49 lbs)
Device dimensions (W x H x D)	Approx. 72 x 90 x 76 mm (2.83 x 3.54 x 2.99 in)
Mounting orientation	As desired
Fastening/mounting – Suitable DIN rails (35 mm / 1.38 in)	<ul style="list-style-type: none"> <li>· TS 35/7.5 according to EN 60715</li> <li>· TS 35/10</li> <li>· TS 35/15 x 1.5</li> </ul>
Impact resistance	IK07 according to IEC 62262
<b>Transport and storage</b>	
The following specifications apply for devices transported and stored in the original packaging.	
Free fall	1 m (39.37 in)
Temperature	K55: –25 °C up to +70 °C (–13 °F up to 158 °F)
Relative humidity	5 to 95% at 25 °C (77 °F), no condensation
<b>Environmental conditions during operation</b>	
The device:	
– Is for weather-protected and stationary use.	
– Fulfills operating conditions according to DIN IEC 60721-3-3.	
– Has protection class II according to IEC 60536 (VDE 0106, part 1), a ground wire connection is not required!	
Rated temperature range	–10 °C up to +55 °C (14 °F up to 131 °F)
Relative humidity	5 to 95% at 25 °C (77 °F), no condensation
Pollution degree	2
Ventilation	No forced ventilation required
Protection against foreign matter and water	IP20 according to EN60529
<b>Interface and energy supply</b>	
JanBus (proprietary)	<ul style="list-style-type: none"> <li>· Via bus connector</li> <li>· The maximum bus length of the JanBus is 100 m.</li> </ul>
<b>Current measurement module 800-CT8-A</b>	
Nominal current	5 A
Channels	<ul style="list-style-type: none"> <li>· 2 systems (L1, L2, L3, N)</li> <li>· Single channels</li> </ul>
Measurement range	0.005 .. 6 A
Crest factor	2 (relative to 6 A <sub>eff</sub> )
Overload for 1 s	120 A (sinusoidal)
Resolution	0.1 mA (color graphic display 0.01A)
Overvoltage category	300 V CAT II
Rated surge voltage	2.5 kV
Power consumption	approx. 0.2 VA (R <sub>i</sub> = 5 mΩ)
Sampling frequency	8.3 kHz
Frequency of the fundamental oscillation	40 Hz ... 70 Hz
Harmonics	1 ... 9. (only odd)
<b>Connecting capacity of the terminals – 800-CT8-A module</b>	
Connectible conductors. Only connect one conductor per terminal point!	
Single core, multi-core, fine-stranded	0.2 – 2.5 mm <sup>2</sup> , AWG 26-12
Wire ferrules (non-insulated) – recommended stripping length	0.2 – 2.5 mm <sup>2</sup> , AWG 26-12 – 10 mm (0.3937 in)
Wire ferrules (insulated) – recommended stripping length	0.2 – 2.5 mm <sup>2</sup> , AWG 26-12 – 13 mm (0.5118 in)
Screw flange tightening torque	0.2 Nm (1.77 lbf in)
Wire ferrules: length of the contact sleeve	10 mm (0.3937 in)



## Dimensional drawings

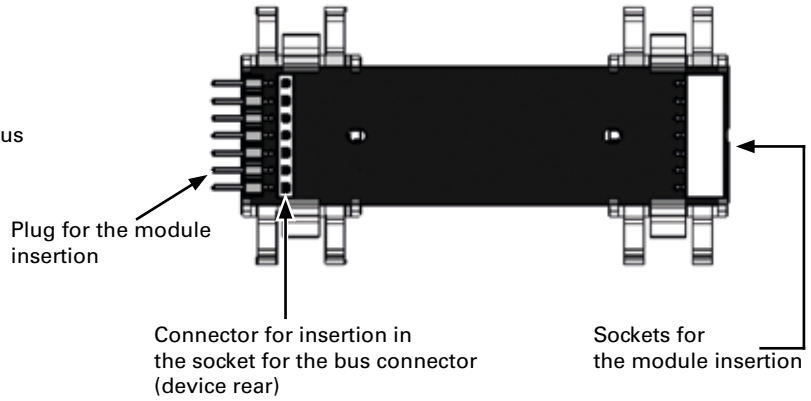
All specifications in mm

Rear view



Socket for bus connector

Bus connector for current measurement module

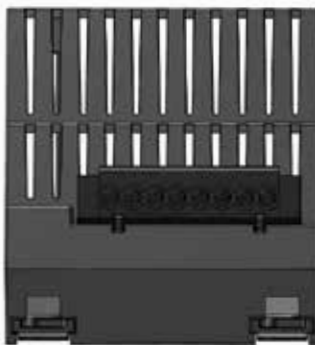


Plug for the module insertion

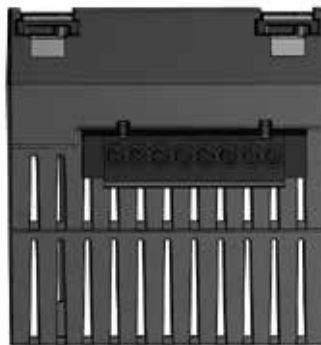
Connector for insertion in the socket for the bus connector (device rear)

Sockets for the module insertion

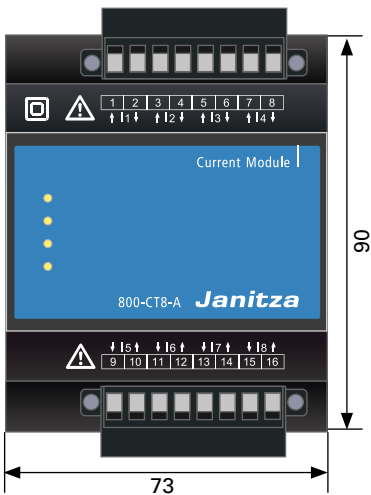
View from below



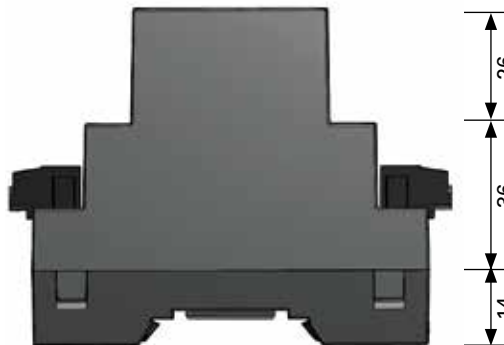
View from above



Front view



View from the left





## Module 800-CON technical data



Module 800-CON <sup>1</sup>	
Item number	52.31.210
<b>General</b>	
Net weight (with plug-in terminals)	Approx. 55 g (0.12 lb) – 1 device
Device dimensions (W x H x D)	Approx. 18 x 90 x 76 mm (0.71 x 3.54 x 2.99 in)
Mounting orientation	As desired
Fastening/mounting – Suitable DIN rails – (35 mm / 1.38 in)	<ul style="list-style-type: none"> <li>· TS 35/7.5 according to EN 60715</li> <li>· TS 35/10</li> <li>· TS 35/15 x 1.5</li> </ul>
Impact resistance	IK07 according to IEC 62262
<b>Transport and storage</b>	
The following specifications apply for devices transported and stored in the original packaging.	
Free fall	1 m (39.37 in)
Temperature	K55: –25 °C up to +70 °C (–13 °F to 158 °F)
Relative humidity	5 to 95% at 25 °C (77 °F), no condensation
<b>Environmental conditions during operation</b>	
The device:	
– Is for weather-protected and stationary use.	
– Fulfills operating conditions according to DIN IEC 60721-3-3.	
– Has protection class II according to IEC 60536 (VDE 0106, part 1), a ground wire connection is not required!	
Rated temperature range	–10 °C up to +55 °C (14 °F up to 131 °F)
Relative humidity	5 to 95% at 25 °C (77 °F), no condensation
Pollution degree	2
Ventilation	No forced ventilation required
Protection against foreign matter and water	IP20 according to EN60529
<b>Interface</b>	
JanBus (proprietary)	– Via bus connector to device and module series
<b>NOTE!</b> To connect the transfer modules, use a twisted pair, stranded, shielded data cable (cable connection 1:1)!	– Via shield clamps between the transfer modules with twisted pair, shielded data cable (cable connection 1:1) – The maximum bus length of the JanBus is 100 m.
<b>Terminal connection capacity</b>	
Connectible conductors Only connect one conductor per terminal point!	
Single core, multi-core, fine-stranded	0.2–1.5 mm <sup>2</sup> , AWG 24-16
Wire ferrules (non-insulated)	0.2–1.5 mm <sup>2</sup> , AWG 26-16
Wire ferrules (insulated)	0.2–1 mm <sup>2</sup> , AWG 26-18
Tightening torque	0.2–0.25 Nm (1.77 - 2.21 lbf in)
Strip length	7 mm (0.2756 in)

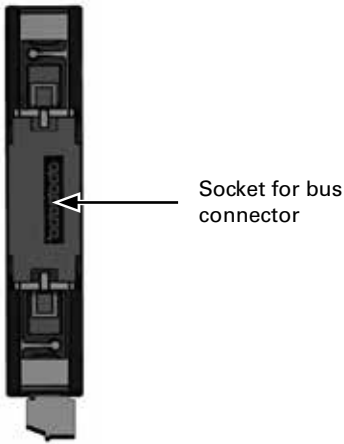
<sup>1</sup> Connection cable not included in the content of a set, optionally available as an accessory.  
Cable length 22.5 cm, item no. 08.02.452  
Cable length 100 cm, item no. 08.02.451



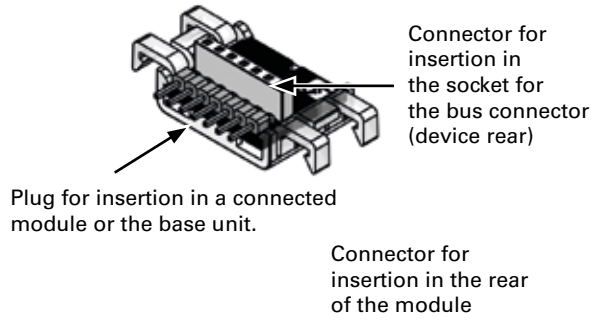
## Dimensional drawings

All specifications in mm

Rear view



Bus connector for transfer module - **output**



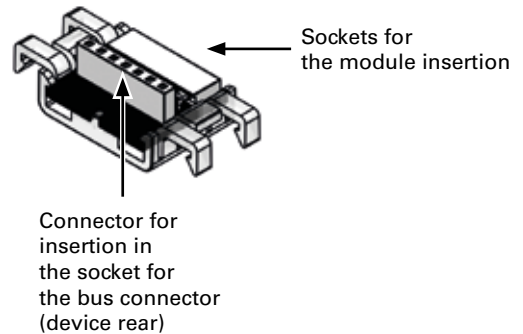
View from below



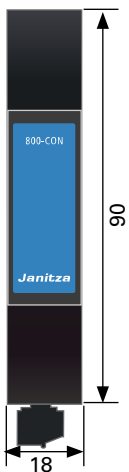
View from above



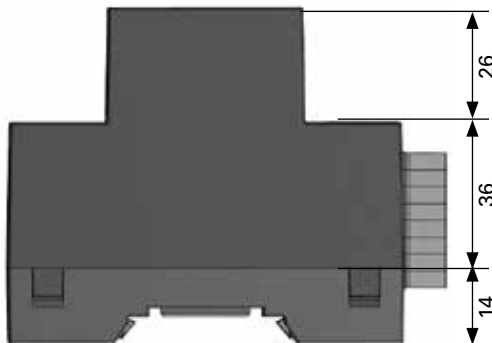
Bus connector for transfer module - **input**



Front view



View from the left



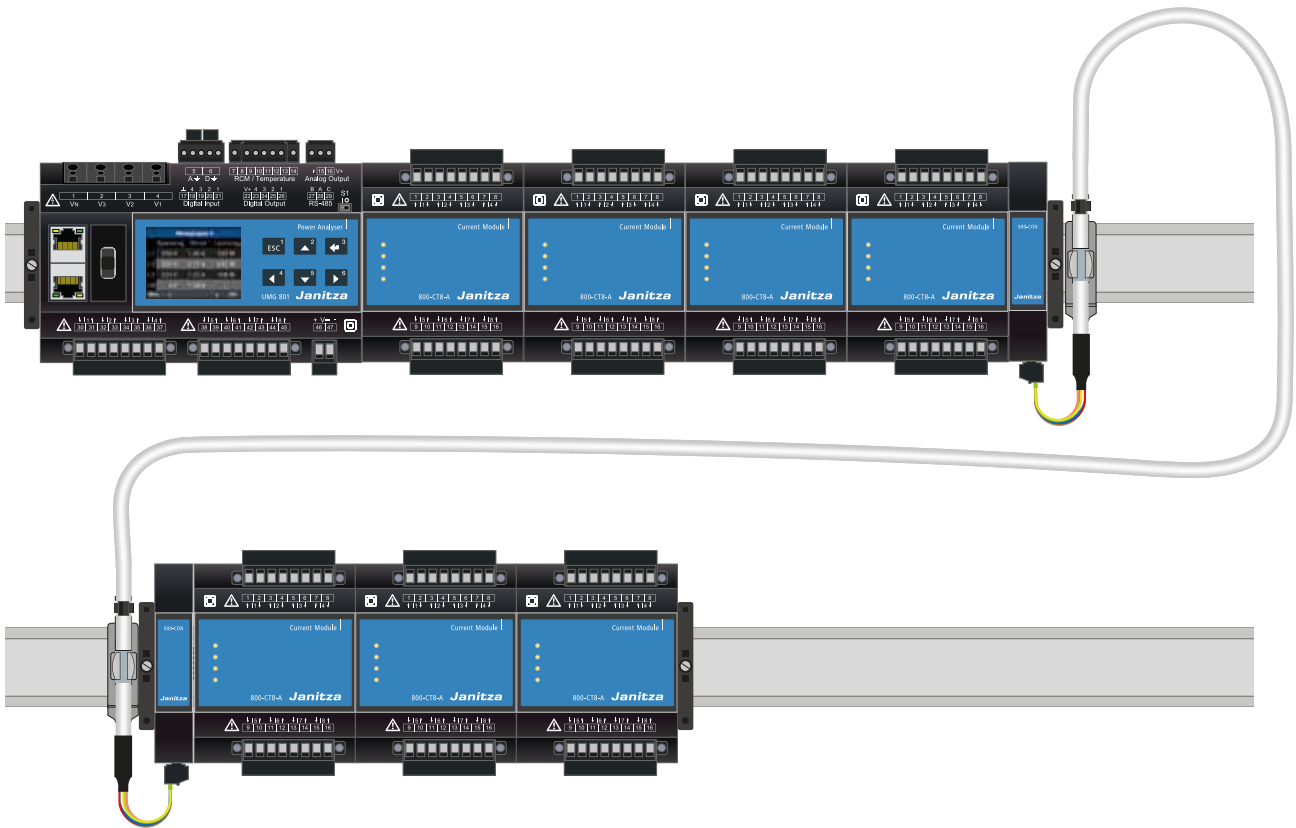


Fig.: Example structure of UMG 801 and modules



## Technical Data Remote Display



	RD 96 <sup>*1</sup>
<b>Item number</b>	<b>52.31.212</b>

<b>Allgemein</b>	
Net weight	approx. 140 g (0.31 lbs)
Package weight (incl. accessories)	approx. 440 g (0.97 lbs)
Dimensions W x H x D without mounting clamps	96 mm x 96 mm x 30 mm (3.78 in x 3.78 in x 1.18 in)
Backlight service life	40000 h (after 40000 h the backlight goes down to approx. 50%)
Impact resistance	IK07 according to IEC 62262

<b>Serial interface (USB)</b>	
USB 2.0 (type A)	1x
USB 2.0 (type B)	1x
Supply voltage	DC 5 V
Nominal current	200 mA
Operating range	+5% of nominal range
Power consumption	1 W

<b>Transport and storage</b>	
The following specifications apply for devices transported and stored in the original packaging.	
Free fall	1 m (39.37 in)
Temperature	-25 °C (-13 °F) bis +70° C (158 °F)
Relative air humidity (non-condensing)	0 to 90% RH

<b>Environmental conditions during operation</b>	
Install the device in a weather-protected and stationary location. Protection class II according to IEC 60536 (VDE 0106, Part 1).	
Rated temperature range	-10 °C (14 °F) to +55 °C (131 °F)
Relative air humidity (non-condensing)	0 to 75% RH
Operating elevation	0 – 2000 m (6562 ft) above sea level
Pollution degree	2
Mounting orientation	As desired
Ventilation	No forced ventilation required
Protection against foreign matter and water	
- Front	IP40 according to EN60529
- Rear	IP20 according to EN60529
- Front with seal	IP54 according to EN60529

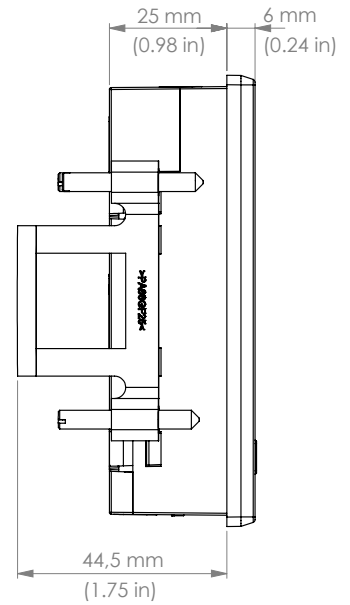
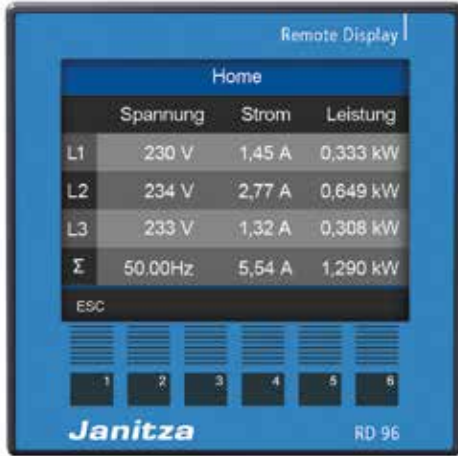
<b>USB cable</b> (included in delivery)	
USB 2.0 (type A to type B connector)	1,8 m (1.97 yd)

<sup>\*1</sup> The USB cable is included in the scope of delivery. The RD 96 works exclusively with the UMG 801.

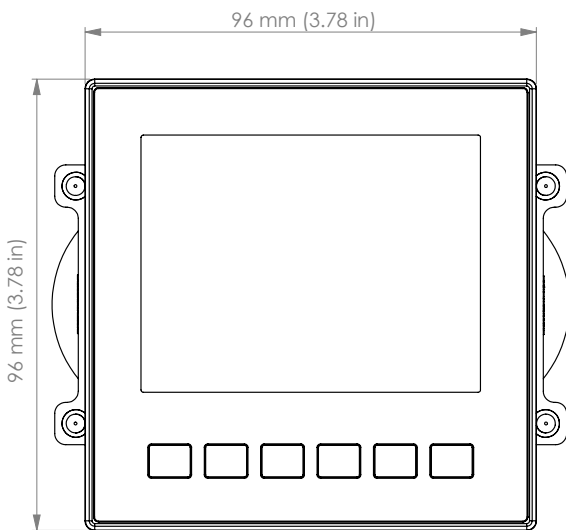


# Dimensional drawings

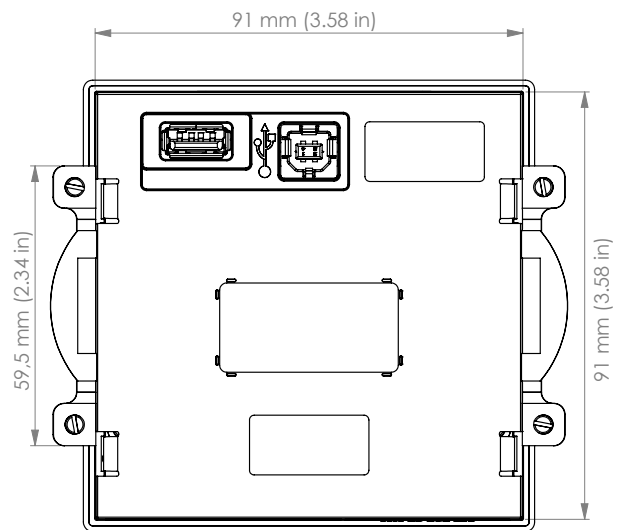
All specifications in mm



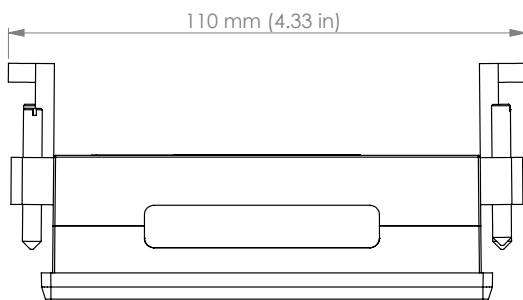
Side view



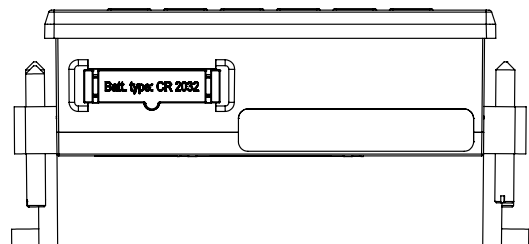
Front view



Rear view



View from above



View from below





# UMG 804

Modular power analyzer for branch circuits

Power quality



Modbus interface



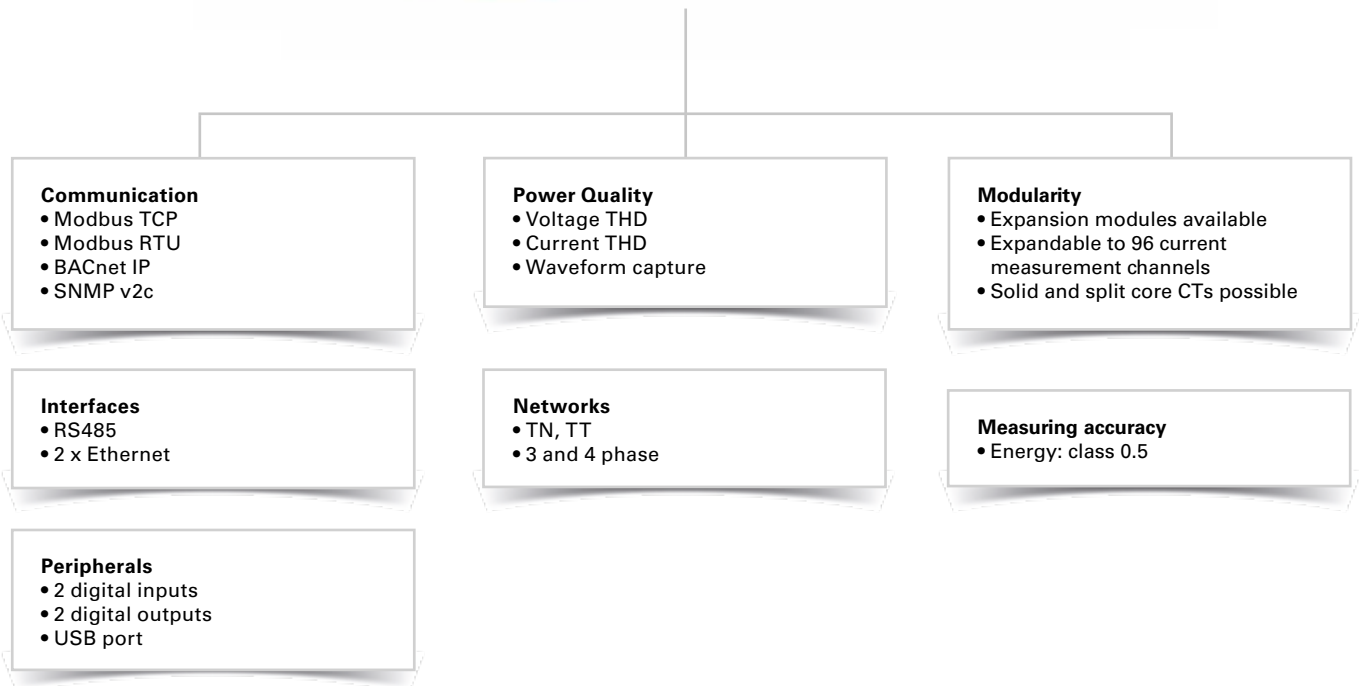
Measurement accuracy 0.5



Expandable to 96 current channels



Homepage



## Areas of application

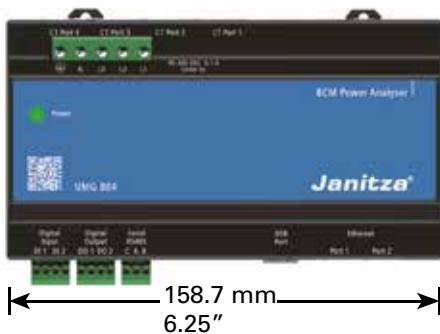


- **Collocation Data Centers:** collocation data center often must monitor the health and energy usage of each branch circuit
- **Lighting/HVAC Energy Optimization:** sub-metering is required to provide the needed resolution to initiate and verify most energy efficiency upgrades
- **Demand Management:** sub-metering identifies energy use by specific loads allowing them to be managed to avoid peak demand charges
- **Tenant Sub-Metering:** commercial facilities are increasingly using sub-metering to allocate costs
- **Switchgear/Power Distribution:** economically identify energy and power use per breaker
- **Circuit/Load Health:** facilities use sub-metering to verify performance of critical loads
- **Energy Use Allocation:** larger buildings and campuses require a means of allocating energy usage for costing purposes
- **High-End Residential:** high end residential automation systems can utilize branch circuit sub-metering to enhance reliability and efficiency

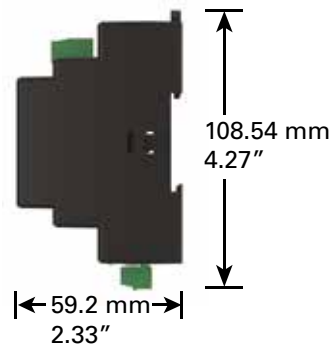


## Dimensional drawings

All specifications in mm



Front view



Side view

## Main features



### Power quality

- Distortion factor THD-U / THD-I
- Waveform capture



### Modular system expansion

- Easy system expansion due to flexible scaling to 96 current measurement channels
- Up to 4 current measurement modules can be connected to the basic device in parallel
- Space optimization through compact design
- No additional power supply required for the measuring modules
- Costs savings through shortened assembly times
- Reduced error sources thanks to Plug & Play solution
- Low costs per additional measurement channel



### Convenient homepage

- Information can be received conveniently via the device's homepage
- Access to powerful device homepage via web browser
- Easy configuration and data management is available direct from the homepage



### Modern communications architecture via Ethernet

- Rapid, cost-optimised and reliable communication through integration into an existing Ethernet architecture
- Integration in PLC systems and building management systems
- High flexibility due to the use of open standards

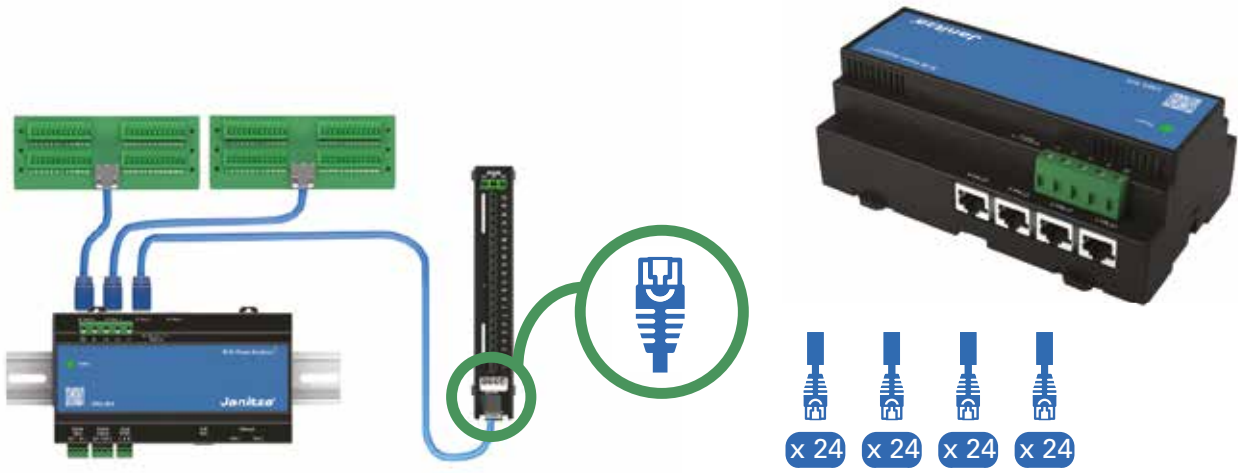


Fig.: DIN Rail CT Interface Boards connect to the Smart Ports on the UMG 804 using network cables.

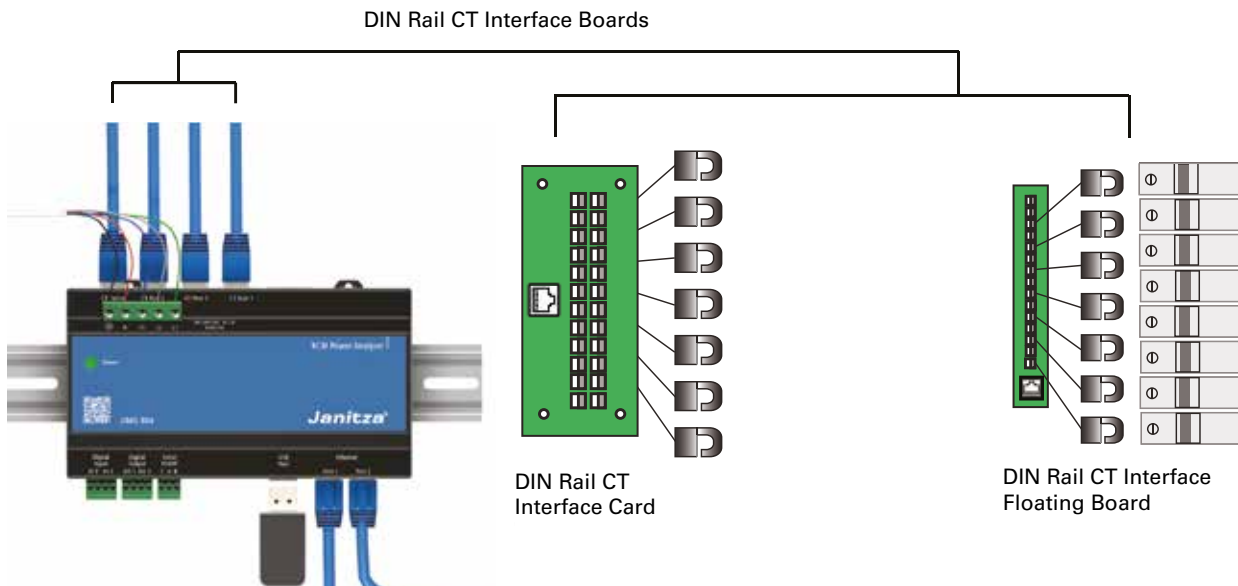


Fig.: DIN Rail CT Interface Boards connect to the Smart Ports on the UMG 804 using network cables.



## Device overview and technical data

Type	Supply voltage	Item number
UMG 804	Supply voltage 90 to 300 V AC	14.02.001
UMG 804 Advanced	Supply voltage 90 to 300 V AC	14.02.002
UMG 804 24 V DC	Supply voltage 12 to 24 V DC	14.02.009
UMG 804 Advanced 24 V DC	Supply voltage 12 to 24 V DC	14.02.010
DIN Rail CT Interface Card	via UMG 804	14.02.003
DIN Rail CT Interface Floating Board	via UMG 804	14.02.004

Current transformer	Primary current in A	Item number
CT-SC-010-50-JZ	50	15.03.170
CT-SC-010-50	50	15.03.133
CT-SC-010-75-JZ	75	15.03.130
CT-SC-010-75	75	15.03.134
CT-SC-012-100-JZ	100	15.03.131
CT-SC-012-100	100	15.03.172
CT-SC-024-100	100	15.03.135
CT-SC-024-200	200	15.03.136
CT-SC-024-250	250	15.03.137
CT-SC-036-400	400	15.03.138
CT-SC-036-600	600	15.03.139

General	
Device dimensions (approx.)	w=158.7 mm, h=108.5 mm, d=59.2 mm (w=6.248 in, h=4.271 in, d=2.330 in)

Transport and storage	
The following information applies to devices which are transported or stored in the original packaging.	
Temperature	-40 °C to 70 °C (-40 °F to 158° F)

Ambient conditions during operation	
The device is intended for weatherproof, fixed installation and must be connected to the ground wire connection! Protection class I in acc. with IEC 60536 (VDE 0106, Part 1).	
Working temperature range	0 °C to 60 °C (32 °F to 140 °F)
Relative humidity	< 95 % RH (without condensation)
Operating altitude	0 .. 2000 m (1.24 mi ) max.
Pollution degree	pollution degree 2
Mounting position	any orientation
Ventilation	not required; 3 W heat rejection
Protection against ingress of solid foreign bodies and water	requires secondary enclosure

<b>AC Power Supply</b>	
Installations of overvoltage category	internally fused; install external fuse as required by code
Protection of the supply voltage (fuse)	1 A @ 300 V AC
Overvoltage category	II, degree 2
Operating range	90 .. 300 V AC (50-60 Hz)
Power consumption	<0.1 A @ 277 VAC (< 3 W)

<b>24 V DC Power Supply</b>	
Installations of overvoltage category	internally fused; install external fuse as required by code
Protection of the supply voltage (fuse)	0.5 A @ 24 V DC
Overvoltage category	III, degree 2
Operating range	12 .. 24 V DC
Power consumption	< 0.5 A @ 12 .. 24 V (< 3 W)

<b>Terminal connection capacity (AC supply voltage)</b>	
Connectable conductors. Only one conductor can be connected per terminal!	
Single core, multi-core, fine-stranded	24-12 AWG / 0.205-3.31 mm <sup>2</sup>
Terminal pins, core end sheath	slot screw type
Tightening torque	5.0 Lb-In / 0.56 Nm
Stripping length	5.5 mm (0.22 in) max.

<b>Terminal connection capacity (DC supply voltage)</b>	
Rigid/flexible	22-16 AWG / 0.324-1.31 mm <sup>2</sup>
Flexible with core end sheath without plastic sleeve	22-16 AWG / 0.324-1.31 mm <sup>2</sup>
Flexible with core end sheath with plastic sleeve	22-16 AWG / 0.324-1.31 mm <sup>2</sup>
Tightening torque	5.0 Lb-In / 0.56 Nm
Stripping length	5 mm (0.20 in) recommended

<b>Current measurement on modules</b>	
Rated current	0 .. 600 A (external current transducer dependant)
Resolution	0.01 A
Crest factor	3.75 @ 100 % of 0.333 V signal
Overload for 1 s	200 %

<b>Voltage measurement</b>	
The voltage measurement inputs are suitable for measurements in the following power supply systems	
Three-phase 4-conductor systems with nominal voltages up to	480 V AC
Three-phase 3-conductor systems, unearthed, with nominal voltages up to	277 V AC
From a safety and reliability perspective, the voltage measurement inputs are designed as follows	
Overvoltage category	230 V: Cat II      24 V: CAT III
Protection of voltage measurement	Impedance limited plus clamping diodes / MOV
Measurement range L-N	0 .. 277 V AC
Measurement range L-L	0 .. 480 V AC
Resolution	0.01 V AC
Crest factor	1.9 @ 240 V AC
Impedance	2.5 M $\Omega$
Power consumption	<0.1 A @ 277 V AC (< 3 W)
Sampling rate	40 kHz
Frequency range of the fundamental oscillation - Resolution	40 .. 70 Hz.

<b>Digital inputs</b>	
Quantity	2

**Note:** two inputs for dry contacts

<b>Digital outputs</b>	
Quantity	2
Switching voltage	30 V DC
Switching current	100 mA
Cable length	screw in terminal block

<b>Terminal connection capacity (digital inputs and outputs)</b>	
Rigid/flexible	22-16 AWG / 0.324-1.31 mm <sup>2</sup>
Flexible with core end sheath without plastic sleeve	22-16 AWG / 0.324-1.31 mm <sup>2</sup>
Flexible with core end sheath with plastic sleeve	22-16 AWG / 0.324-1.31 mm <sup>2</sup>
Tightening torque	5.0 Lb-In / 0.56 Nm
Stripping length	5 mm (0.20 in) recommended

<b>RS485 interface</b> x-wire connection	
Protocol	MODBUS-RTU
Transmission rate	9600, 19200, 38400, 57600, 115200 Baud
Termination resistor	120 $\Omega$ (consult manual on master device)

<b>Ethernet interface</b>	
Connection	10/100
Function	Supports Modbus output as well as direct polling of HTML web pages from onboard server
Protocols	Modbus TCP/IP, BACnet IP

**Note:** dual Ethernet ports to allow for connection of multiple devices without the requirement of switch. REST protocols is supported.

<b>Accuracy</b>	
Measurement uncertainty on the device applies when using the following metering ranges. The measured value must be within the specified limits. The measurement uncertainty is not specified outside of these limits.	
Power/ Energy CT Strip	IEC 62053-21 Class 0.5* <sup>1</sup> , ANSI C12.1-2008
Power/ Energy Floating Strip/ Din Rail Board	IEC 62053-21 Class 0.5* <sup>1</sup> , ANSI C12.1-2008
Voltage	± 0.5 % of reading 90 to 277 VAC line-to-neutral
Current L	Subject to external CT accuracy
Minimum ON Current	50 mA
Circuit capacity	24 x 4 channels (96 circuits total)

\*<sup>1</sup> in combination with the AC Split Core Current Transformers CT-SC-010, CT-SC-012, CT-SC-024, CT-SC-036

<b>AC Split Core Current Transformers Specifications</b>
Voltage outputs @ 0.333 V
Frequency 50 Hz - 400 Hz
Operating temperature -40 °C to 70 °C (-40 °F to 158 °F)
Storage temperature -45 °C to 85 °C (-49 °F to 185 °F)
UL certified

Module	Art. no.	Input current	Ø mm (in)	Cable length m (in)	Accuracy class	Usable for interface
CT-SC-010-50-JZ	15.03.170	50 A	10 (0.394)	0.25 (9.84)	0.5* <sup>2</sup>	Floating
CT-SC-010-50	15.03.133	50 A	10 (0.394)	2,0 (78.74)	0.5* <sup>2</sup>	DIN-Rail
CT-SC-010-75-JZ	15.03.130	75 A	10 (0.394)	0.25 (9.84)	0.5* <sup>2</sup>	Floating
CT-SC-010-75	15.03.134	75 A	10 (0.394)	2,0 (78.74)	0.5* <sup>2</sup>	DIN-Rail
CT-SC-012-100-JZ	15.03.131	100 A	12 (0.472)	0.25 (9.84)	0.5* <sup>2</sup>	Floating
CT-SC-012-100	15.03.172	100 A	12 (0.472)	2,0 (78.74)	0.5* <sup>2</sup>	DIN-Rail
CT-SC-024-100	15.03.135	100 A	24 (0.945)	2,0 (78.74)	0.5* <sup>2</sup>	DIN-Rail
CT-SC-024-200	15.03.136	200 A	24 (0.945)	2,0 (78.74)	0.5* <sup>2</sup>	DIN-Rail
CT-SC-024-250	15.03.137	250 A	24 (0.945)	2,0 (78.74)	0.5* <sup>2</sup>	DIN-Rail
CT-SC-036-400	15.03.138	400 A	36 (1.420)	2,0 (78.74)	0.5* <sup>2</sup>	DIN-Rail
CT-SC-036-600	15.03.139	600 A	36 (1.420)	2,0 (78.74)	0.5* <sup>2</sup>	DIN-Rail

\*<sup>2</sup> In combination with the UMG 804 and the DIN Rail CT Interface Floating Board / DIN Rail CT Interface Card.

Further information can be found in the separate data sheet for the current transformers.



# UMG 806

Modular universal measurement device



## Areas of application

- Data centres
- Industrial energy distribution systems
- Building installation on distribution boards, circuit breakers and busbar systems

## Main features



### Power quality

- Harmonics current up to the 31st harmonic
- Unbalance
- Distortion factor THD-U / THD-I



### Communication

- Fast, cost-optimized and reliable communication through connection to an existing Ethernet architecture
- High flexibility through use of open standards
- Easy integration of measurement data from the basic device



### Ethernet-Modbus-Gateway

- Easy integration of Modbus-RTU devices into an Ethernet architecture through the modbus-gateway-function
- Integration of devices with identical file format and matching function codes through Modbus-RTU-interface possible



### Measurement devices with an accuracy of 0.2% (V), kWh-class 0.5S

- Sampling rate 8 kHz/Phase (V)
- Reliable measuring accuracy of 0.2% (I)
- Active energy class (kWh): 0.5S

### Modular plant expansion

- Easy plant expansion through modules with additional in- and outputs
- Space optimization through compact structure



## Technical data basic device

	<b>UMG 806</b>
<b>Item number</b>	<b>14.02.025</b>
Supply voltage	80 ... 270 V AC; 80 ... 270 V DC

General	
Net weight	300 g (0.66 lb)
Device dimensions	approx. B = 90 mm (3.54 in), H = 90 mm (3.54 in), D = 63.5 mm (2.5 in)
Battery	Type Li-Mn CR2032, 3 V
Backlight service life	45000 h (50 % of the initial brightness)
Mounting orientation	As desired
Impact resistance	IK04 according to IEC 62262

Transport and storage	
The following specifications apply for devices transported and stored in the original packaging.	
Free fall	1 m (39.37 in)
Temperature	-30° C (-17.2 °F) to +80° C (176 °F)
Relative humidity	5 to 95% RH at 77 °F (25 °C), non-condensing

Environmental conditions during operation	
The device:	
<ul style="list-style-type: none"> <li>• For weather-protected and stationary use.</li> <li>• Fulfills operating conditions according to DIN IEC 60721-3-3.</li> <li>• Has protection class II according to IEC 60536 (VDE 0106, part 1), a ground wire connection is not required!</li> </ul>	
Rated temperature range	-25 °C (-13 °F) to +70 °C (158 °F)
Relative humidity	5 to 95 % at 77 °F (25 °C), non-condensing
Operating elevation/overvoltage category	< 2500 m (13123 ft) above sea level
Pollution degree	2
Ventilation	No forced ventilation required.
Protection against foreign matter and water	IP20 according to EN60529

Supply voltage	
Nominal range	AC/DC: 80 V - 270 V
Operating range	+/-10 % of nominal range
Power consumption	max. 7 VA
Recommended overcurrent protective device for line protection	5 A, (Char. B), IEC-/UL approval

Voltage measurement	
3-phase 4-conductor systems with rated voltages up to	230 V <sub>LN</sub> / 400 V <sub>LL</sub> (+/-10 %) acc. to IEC
3-phase 3-conductor systems (grounded) with rated voltages up to	400 V <sub>LL</sub> (+/-10 %) acc. to IEC
Overvoltage category	300 V CAT III according to IEC
Rated surge voltage	4 kV
Protection of the voltage measurement	1 - 10 A tripping characteristic B (with IEC/UL approval)
Measuring range L-N	0.. 230 V <sub>eff</sub> (max. overvoltage 277 V <sub>eff</sub> )
Measuring range L-L	0.. 400 V <sub>eff</sub> (max. overvoltage 480 V <sub>eff</sub> )
Resolution	0.1 V
Crest factor	2 (referred to measuring range 230 V L-N)
Impedance	>1.7 MΩ/Phase
Power consumption	approx. 0.1 VA / phase
Sampling frequency	8 kHz / phase
Frequency of fundamental oscillation	45 Hz .. 65 Hz
- Resolution	0.01 Hz
Harmonics	1 .. 31.

<b>Current measurement (../1 A) (../5 A)</b>	
Nominal current	5 A
Channels	4
Measuring range	0.005 .. 6 A <sub>eff</sub>
Crest factor (relative to the nominal current)	2
Overload for 1 s	100 A (sinusoidal)
Resolution	1 mA
Overvoltage category	300 V CATII
Rated surge voltage	4 kV
Power consumption	approx. 0.2 VA
Sampling frequency	8 kHz
Harmonics	1 .. 31.

<b>Current measurement (measuring range 0 .. 40 mA, AC)</b>	
Channel I5	1

<b>Digital outputs</b>	
<b>Energy pulse output</b>	
Switching voltage	max. 35 V DC
Switching current	max. 10 mA <sub>eff</sub> DC
Response time	approx. 500 ms
Pulse width	80 ms ±20 %
Digital output (energy pulses)	max. 10 Hz

<b>Temperature measurement</b>	
Update time	1 s
Total load (sensor and cable)	max. 0.35 kΩ
Suitable sensor types	PT100

<b>Cable length (digital output, temperature measurement)</b>	
Up to 30 m (32.81 yd)	Unshielded
Greater than 30 m (32.81 yd)	Shielded

<b>RS-485 interface</b>	
<b>2-wire connection</b>	
Protocol	Modbus RTU
Transmission rate	up to 115.2 kbps

<b>Connecting capacity of the terminals (supply voltage)</b>	
Connectible conductors. Only connect one conductor per terminal point!	
Single core, multi-core, fine-stranded	0.14 - 2.5 mm <sup>2</sup> , AWG 26-14
Wire ferrules (non-insulated)	0.25 - 2.5 mm <sup>2</sup> , AWG 23-14
Wire ferrules (insulated)	0.25 - 1.5 mm <sup>2</sup> , AWG 23-16
Tightening torque	0.5 - 0.6 Nm (4.43 - 5.31 lbf in)
Strip length	7 mm (0.2756 in)

Connecting capacity of the terminals (current measurement)	
Connectible conductors. Only connect one conductor per terminal point!	
Single core, multi-core, fine-stranded	0.2 - 4 mm <sup>2</sup> , AWG 24-12
Wire ferrules (non-insulated)	0.25 - 2.5 mm <sup>2</sup> , AWG 23-14
Wire ferrules (insulated)	0.25 - 1.5 mm <sup>2</sup> , AWG 23-16
Tightening torque	0.5 - 0.6 Nm (4.43 - 5.31 lbf in)
Strip length	7 mm (0.2756 in)

Connecting capacity of the terminals (voltage measurement)	
Connectible conductors. Only connect one conductor per terminal point!	
Single core, multi-core, fine-stranded	0.2 - 4 mm <sup>2</sup> , AWG 24-12
Wire ferrules (insulated/non-insulated)	0.25 - 2.5 mm <sup>2</sup> , AWG 23-14
Strip length	7 mm (0.2756 in)

Connection capacity of the terminals (RS-485, digital output, temperature measurement)	
Single core, multi-core, fine-stranded	0.2 - 4 mm <sup>2</sup> , AWG 24-12
Wire ferrules (non-insulated)	0.25 - 2.5 mm <sup>2</sup> , AWG 23-14
Wire ferrules (insulated)	0.25 - 1.5 mm <sup>2</sup> , AWG 23-16
Tightening torque	0.5 - 0.6 Nm (4.43 - 5.31 lbf in)
Strip length	7 mm (0.2756 in)

Firmware	
Firmware update	Please observe the operating instructions

Remark: For detailed technical information, please refer to the operation manual and Modbus address list.



Fig.: The basic device is compatible with every type 806 module



## Technical data of the modules

General			
	806-EC1	806-EI1	806-ED1
Net weight	82g (0.18 lb)	91g (0.20 lb)	82 g (0.18 lb)
Device dimensions	B = 36 mm (1.42 in), H = 90 mm (3.54 in), T = 63.5 mm (2.5 in)		
Mounting orientation	As desired		
Installation - suitable DIN rails - 35 mm (1.38")	According to EN 60715		
Impact resistance	IK04 according to IEC 62262		

Transport and storage	
The following specifications apply for devices transported and stored in the original packaging.	
Free fall	1 m (39.37 in)
Temperature	-40° C (-40 °F) to +85° C (185 °F)
Relative humidity	5 to 95% RH at 77 °F (25 °C), non-condensing

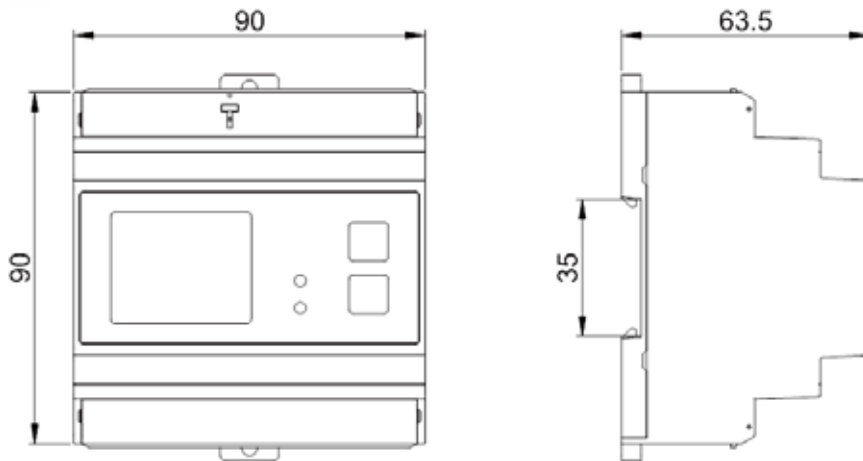
Environmental conditions during operation	
The device:	
<ul style="list-style-type: none"> <li>• For weather-protected and stationary use.</li> <li>• Fulfills operating conditions according to DIN IEC 60721-3-3.</li> <li>• Has protection class II according to IEC 60536 (VDE 0106, part 1), a ground wire connection is not required!</li> </ul>	
Rated temperature range	-40 °C (-40 °F) to +70 °C (158 °F)
Relative humidity	5 to 95 % at 77 °F (25 °C), non-condensing
Operating elevation	< 2500 m (13123 ft) above sea level
Pollution degree	2
Ventilation	No forced ventilation required.
Protection against foreign matter and water	IP20 according to EN60529

806-EC1 module	
Ethernet communication module	
Interface	RJ45 (10M)
Transmission technology	IEE 802.3
Operating mode	Server
MAC	IEEE certification
IP	Static
Protocol	Modbus/TCP, SNMP V2c
Function	Modbus Gateway
Isolation voltage	1.5 kV AC



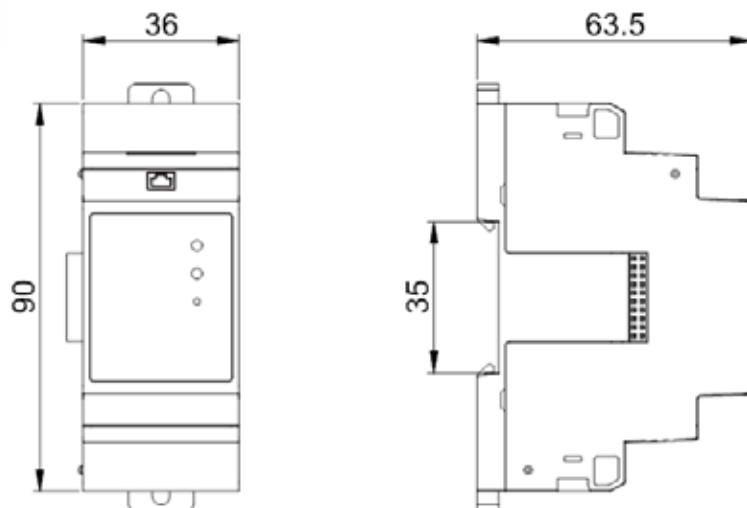
## Dimensional diagrams basic device

All dimensions in mm



## Dimensional diagrams modul 806-EC1

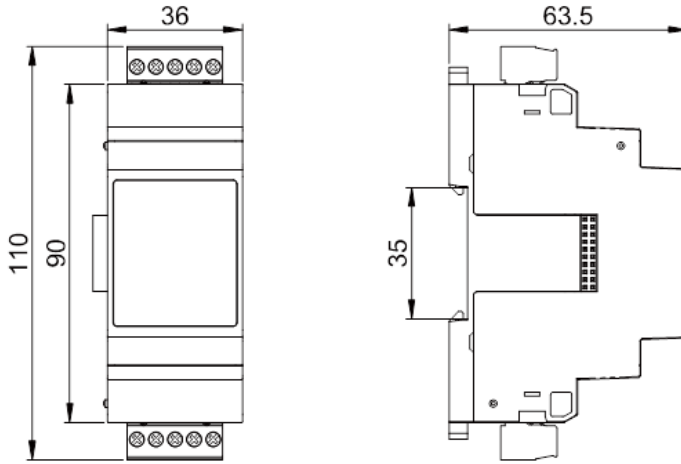
All dimensions in mm





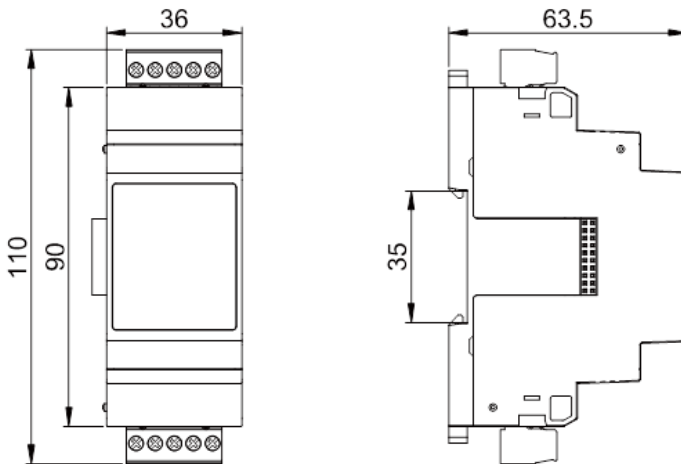
## Dimensional diagrams modul 806-ED1

All dimensions in mm



## Dimensional diagrams modul 806-EI1

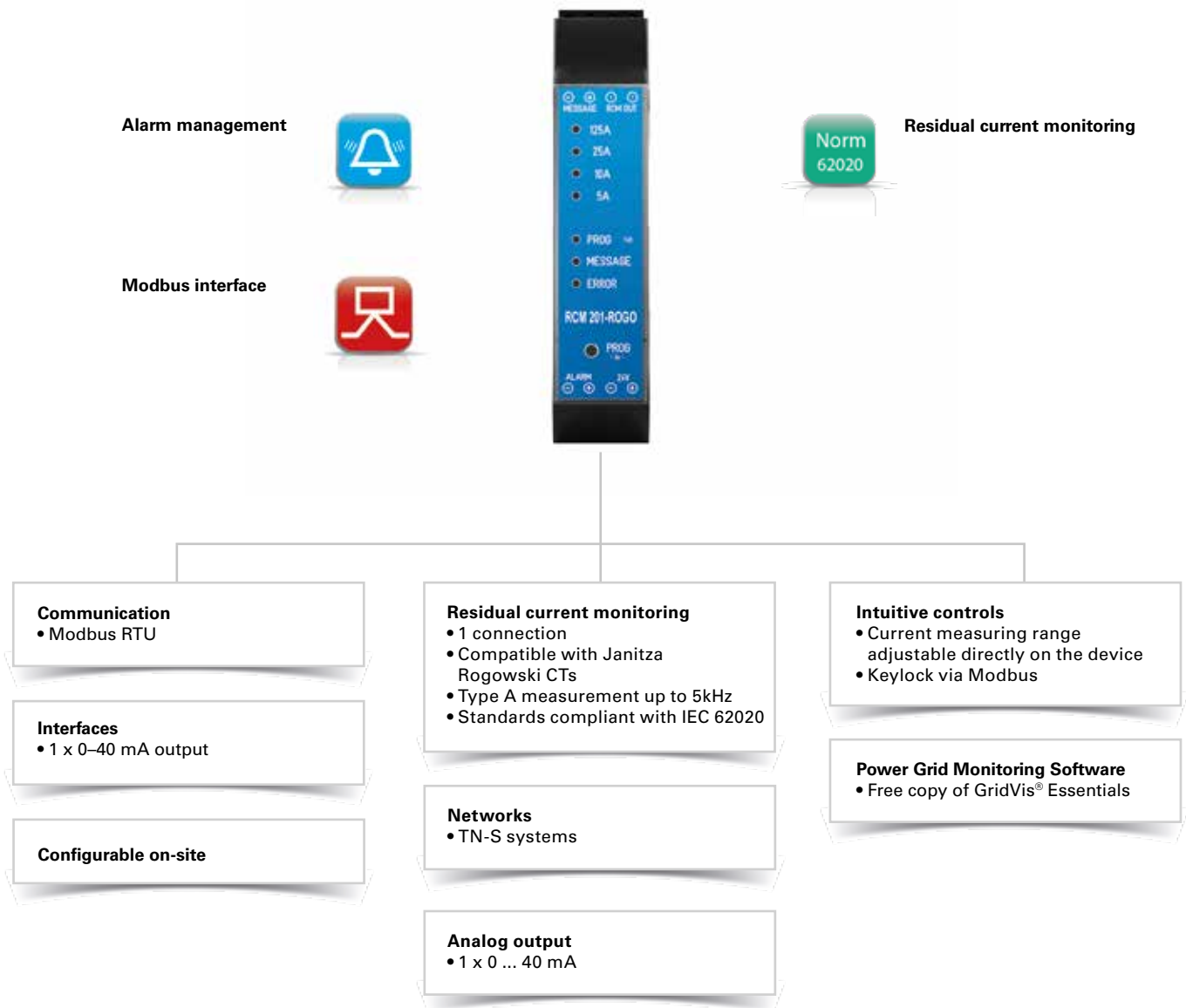
All dimensions in mm





# RCM 201-ROGO

Residual current monitoring device, type A,  
for Rogowski CTs



## Areas of application



- Residual current monitoring in:
  - Industrial plants
  - Data centres
  - Hospitals
- Standards compliant measurement to minimize DGUV V3

## Main features



### High measurement accuracy

- From 2% to final value
- Measurement of residual currents in the measurement ranges 5 / 10 / 25 / 125 A



### Standards – compliant to IEC 62020

- Recording, evaluation and monitoring of type A residual currents

### Retrofittable

- Rogowski RCM current transformers for large cable cross sections and busbars up to 4000 A



### Alarm function

- Configurable limit values and alarm output via digital output and Modbus



### Communication

- RS485 interface (protocol Modbus RTU)
- Compatible with all communication-enabled Janitza Modbus master devices





## Device overview and technical specifications

Rogowski coils	
Item number (Ø 120 mm, coil length 350 mm / Ø 4.72 in, coil length 13.78 in)	15.03.615
Item number (Ø 200 mm, coil length 600 mm) / Ø 7.87 in, coil length 23.62 in)	15.03.616
Item number (Ø 290 mm, coil length 900 mm) / Ø 11.42 in, coil length 35.43 in)	15.03.617
Item number (Ø 390 mm, coil length 1200 mm) / Ø 15.35 in, coil length 47.24 in)	15.03.618
Item number (Ø 580 mm, coil length 1800 mm) / Ø 22.83 in, coil length 70.87 in)	15.03.619
Cable length connection line	3.0 m
Lock	Bayonet
Operating temperature	-30 °C to +80 °C (-22 °F ... 176 °F)
Storage temperature	-40 °C to +80 °C (-40 °F ... 176 °F)
Secondary voltage	100 mV/1kA @ 50 Hz
Overvoltage category	1000 Veff CAT III 600 Veff CAT IV
Protection class	IP67

RCM 201-ROGO	
Item number	15.03.614
Dimensions	22.5 x 100 x 110 mm (W x H x D) 0.89 x 3.94 x 4.33 in (w x h x d)
Weight	approx. 0.2 kg (0.44 lb)
Power supply	24 V <sub>DC</sub> / 0.1 A
Connections	Screw terminal (max. 2,5 mm <sup>2</sup> )
Rogowski loop connection	Mini-Din 4-pole
Rated response differential current measuring ranges	2.5 A – 125 A 0.5 A – 25 A 0.2 A – 10 A 0.1 A – 5 A
Current measuring range setting	Manually using the key (> 3 sec) or Modbus (measuring range selection via micro-controller and PGA)
Signal and alarm output test	Manually using the key (> 6 sec) or Modbus
Operation and measuring range display	Measuring range display: LED green Measuring range selection: LED yellow Signal output: LED yellow Alarm output: LED red
Nominal input voltage	100 µV / A
Current output	0 – 40 mA ~
Max. current output for load = 0 Ω	70 mA ~
Overload current (duration)	50 kA
Overload current (max. 1 sec)	100 kA
Transmission error	40 Hz ... 60 Hz < 2% 60 Hz ... 5 kHz < 5%
Rated frequency	40 Hz – 5 kHz
Load (40 mA output)	0 – 10 Ω
Operating lock	via MODBUS
Alarm output potential-free (Opto) (Programming via MODBUS)	Transistor output 24 V <sub>DC</sub> / 100 mA
Output	Alarm normal (NO) Alarm inverted (NC)
Alarm functions	Residual current level Measurement loop circuit Overtemperature Undervoltage (24 V) Internal error
Response differential current alarm output	10 % – 100 % (0.5 % steps)
Hysteresis response differential current level	5 % (0 – 30 %)
Response time alarm output	10 s (1 – 255 s)

## Chapter 02

### RCM 201-ROGO

Alarm output potential-free (Opto)	Transistor output 24 V <sub>DC</sub> / 100 mA
Signal output functions	Residual current level normal (NO) Residual current inverted (NC)
Response residual current signal output	5% – 100% (0.5% steps)
Signal output hysteresis	5% (0 – 30%)
Signal output response time	5 s (1 s – 255 s)

Interface	RS485 (electrically isolated)
Communication protocol	MODBUS RTU
Baud rate	9600 – 250000; programmable via Modbus
Address	1 (1 – 255); programmable via Modbus

Note: in order to ensure smooth operation of the Rogowski coils, a combination of the coil and the Janitza measurement transducer "RCM 201-ROGO" is always necessary! Additionally a 24 V DC power supply is needed. The combination of the coil and the measurement transducer is not compatible with the UMG 20CM.

Comment: For detailed technical information please refer to the operation manual and the Modbus address list.

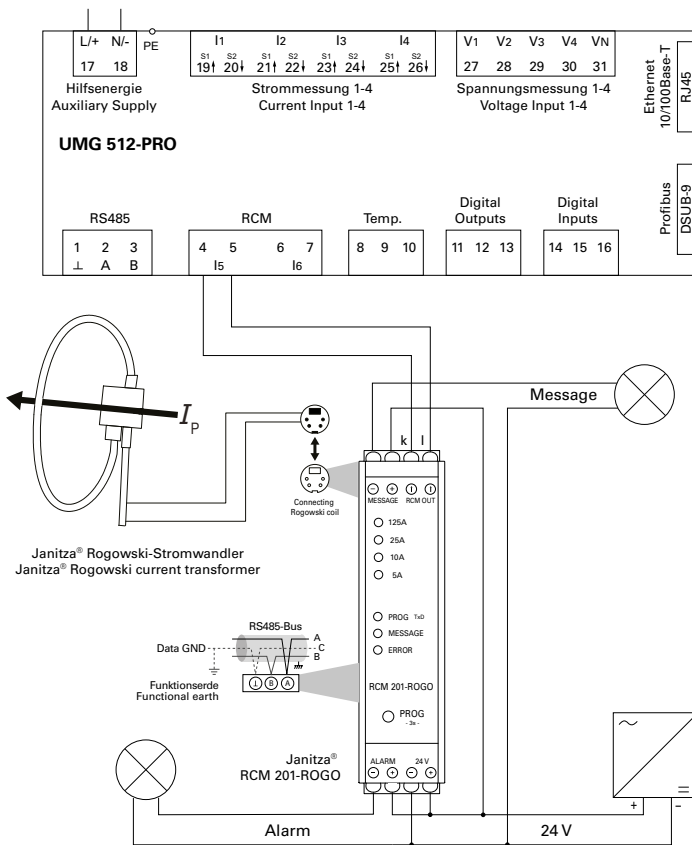


Fig.: Connection example to an UMG 512-PRO

# RCM 202-AB

Residual current monitoring device, type AB

Alarm management



Modbus interface



Norm  
62020

Residual current monitoring

**Communication**

- Modbus RTU

**Interfaces**

- 2 x 4-20 mA outputs
- 2 digital outputs

**RCM – Residual Current Monitoring**

- 2 residual current inputs

**Residual current monitoring**

- 2 channels
- Compatible with all Janitza residual current transformers
- Universally current sensitive up to 20 kHz
- IEC 62020 compliant

**Completely configurable on site**

**Display**

- LCD display
- Display of the momentarily measured current values
- Errors and alarms

**Networks**

- TN, TT networks

**Power Grid Monitoring Software**

- Free copy of GridVis® Essentials

## Areas of application



- Residual current monitoring in industrial installations
- Computing centers
- Hospitals
- Standards compliant measurement to minimize DGUV V3

## Main features

The RCM 202-AB is employed with current transformers connected for the measurement and monitoring of residual currents of the types A, B and B+ in TN and TT systems (grounded AC systems).

- Residual current measurement using up to two connected current transformers (compatible with all Janitza residual current transformers)
- Transformer connection monitoring for wire break or short circuits per channel
- Acquisition, evaluation and monitoring of residual currents of types A, B and B+ to IEC 62020
- Acquisition of sinusoidal AC fault currents with frequencies of up to 20 kHz (type B+)
- Acquisition of purely DC currents
- Measured and extreme values memory with time stamp

### Measuring channels

- Two current transformer connections (compatible with all Janitza residual current transformers)
- AC/DC measurement range: 10 mA ... 20 A

### Measuring display and operation

- Two-color LED display (128 x 64 pixels)
- 3-button control
- Self test and check indicator
- German, English and Spanish user guidance can be selected

### RCM analysis variables

- Individual limit values can be set for type A, type B, and type B+
- Individual frequencies for 1-2000 Hz
- Spectrum display for 2-20 kHz

### Peripherals

- 2 digital alarm outputs, 2 freely scalable analog outputs

### Communication

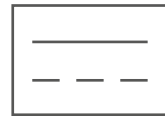
- RS485 interface (protocol: Modbus RTU)
- Compatible with all communications-capable Janitza Modbus master devices



**A Sensitive to pulsed current**  
Sinusoidal alternating current  
pulsed direct current



**B Universally current sensitive**  
All currents up to 2 kHz

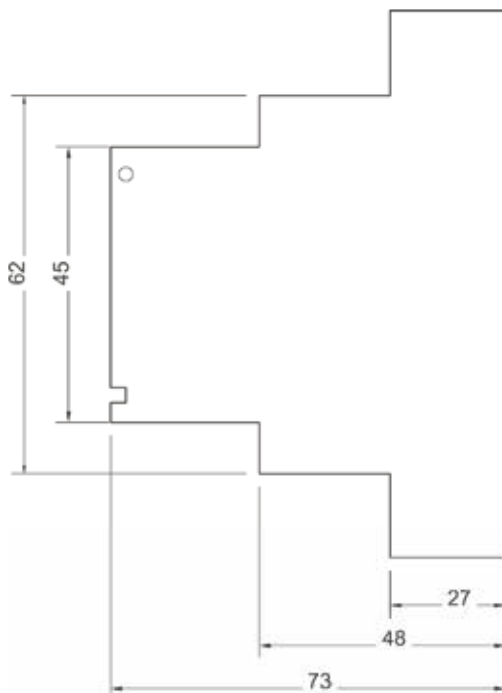


**B+ Universally current sensitive**  
All currents up to 20 kHz



## Dimensional drawings

All dimensions in mm



Side view



Front view



## Device overview and technical specifications

	RCM 202-AB
<b>Part number</b>	<b>14.01.627</b>
<b>General</b>	
Supply voltage $U_s$	AC 90 ... 276 V, 50/60 Hz
Required external back-up fuse for the power supply	Circuit breaker 1 pole, 3 A, AC 230 V
Operating mode	Continuous operation
Power consumption (internal consumption)	8 W
<b>Isolation coordination according to IEC 60664-1</b>	
Rated current $I_b$	4 kA
Rated surge voltage	4 kV
Pollution degree	3
Rated voltage	AC 250 V, 50 ... 60 Hz
<b>Monitored system</b>	
<b>Measurement transformer types/transformation ratio:</b>	
Residual current measuring transducer	See Tab. 5 on page 64
Current measurement transformer rated voltage	AC 20 ... 720 V
Current measurement transformer rated frequency	0 ... 20 kHz
Current measurement transformer rated current	(depending on the type)
<b>Measurement channels</b>	
Number of measuring channels	2 (connectable current measurement transformers)
Measured value recording	Parallel, effective value measurement (true RMS)
Evaluation	Residual currents Type A and B according to IEC 62020
Measurement response residual current $I_{An}$	parameterizable, 30 mA ... 20 A
Response delay time of the warning and alarm messages $t_{vr}$	parameterizable, 10 ms ... 10 s
Reset delay time $t_{vr}$	parameterizable, 10 ms ... 10 s
<b>Transformer connections</b>	
Connection to the current measurement transformers	Line resistance max. 2 $\Omega$
Line/transformer	2-wire
<b>Line length:</b>	
Single wires (0.75 to 1.5 mm <sup>2</sup> )	max. 1 m
Twisted single wires (0.75 to 1.5 mm <sup>2</sup> )	max. 10 m
Shielded cable (0.75 to 1.5 mm <sup>2</sup> )	max. 10 m
<b>Displays, messages and memory</b>	
Full graphics display (LCD)	128 x 64 pixel with backlight
Status LED	3-color
Controls	3 keys
Menu languages	German, English, Spanish
Date and time	with RTC, stored in the non-volatile memory
Parameterization	on RCM 202-AB in the configuration menu
Messages	Display, LED, Modbus, digital outputs
Measured value memory	18,725 datasets (circular buffer) with date and time
<b>Examples:</b>	
Shielded cable 0.75 mm <sup>2</sup> (shield on I)	Max. length 20 m (21.87 yd)
Cable type J-Y(ST)Y $\varnothing$ 0.6 mm	Max. length 15 m (16.4 yd)
<b>Analog outputs</b>	
Interface	4 ... 20 mA
Quantity	2
Supply voltage of the analog outputs	DC 12 ... 24 V
<b>Digital outputs</b>	
Number of digital outputs	2
Switching voltage	max. DC 60 V, AC 30 V
Maximum current	350 mA
Start-up resistance	2 $\Omega$
Maximum cable length	up to 30 m (32.8 yd) unshielded, above 30 m (32.8 yd) shielded



<b>RS485 interface</b>	
Protocol	Modbus-RTU (RCM 202-AB as the slave)
Interface	RS485
Baud rate	parameterizable, 9.6 ... 115.2 kbaud
Address range	1 ... 247
max. cable length (38.4 kbaud)	1200 m (1212.3 yd)
Cable (shielded, shield one-sided on PE)	Unitronic Li2YCY(TP) 2x2x0.22 (Lapp cable)
Termination resistor	120 Ω (can be activated on the device)
<b>Device safety</b>	
Safety regulations for electrical measurement, control, regulation and laboratory devices	
Part 1: General requirements	IEC/EN 61010-1
Part 2-030: Particular requirements for equipment having testing or measuring circuits	IEC/EN 61010-2-030
<b>Electromagnetic compatibility (EMC)</b>	
<b>Immunity from interference</b>	
Class A: Industrial sector	IEC/EN 61326-1
Electrostatic discharges	IEC/EN 61000-4-2
Voltage dips	IEC/EN 61000-4-11
<b>Emissions</b>	
Class B: Residential sector	IEC/EN 61326-1
RFI field strength 30 ... 1000 MHz	IEC/CISPR11/EN 55011
Radiated interference voltage 0.15 ... 30 MHz	IEC/CISPR11/EN 55011
<b>Standards</b>	
The RCM 202-AB fulfills the requirements according to EN 62020:1998+A1:2005 (VDE 0663):2005	
<b>Ambient conditions</b>	
Ambient temperature during operation	-5 ... +55 °C (23 °F .. 131 °F)
Ambient temperature during storage	-25 ... +70 °C (-13 °F .. 158 °F)
Ambient temperature during transport	-25 ... +70 °C (-13 °F .. 158 °F)
Altitude	0 ... 2000 m (0 ... 1.24 mi)
Climate category according to IEC 60721-3-3 (operation)	3K5
<b>Installation conditions</b>	
Installation position	Horizontal/vertical
Assembly	Top hat rail per DIN EN 60715
Device dimensions in mm (H x W x D)	71 x 90 x 73
Protection class according to EN 60259	IP 20
Protection class	II
Flammability rating	UL94V-0
Weight	approx. 170 g (0.375 lb)
Connection type/cable	Series terminal/copper
Connection cross section single-wire/finely stranded	0,2 ... 4 mm <sup>2</sup> /0,2 ... 1,5 mm <sup>2</sup> (AWG 24-15)

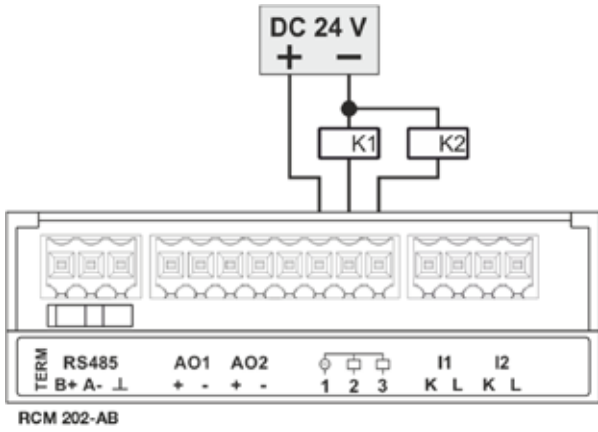


Fig.: Application example RCM 202-AB in stand-alone mode – connection of two relays to the digital outputs

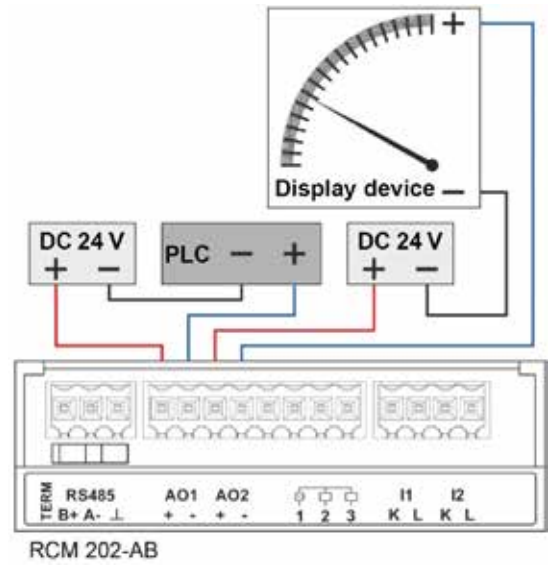


Fig.: Application example analog outputs (interface 4 ... 20 mA) – connection of a display device and a PLC to the analog outputs

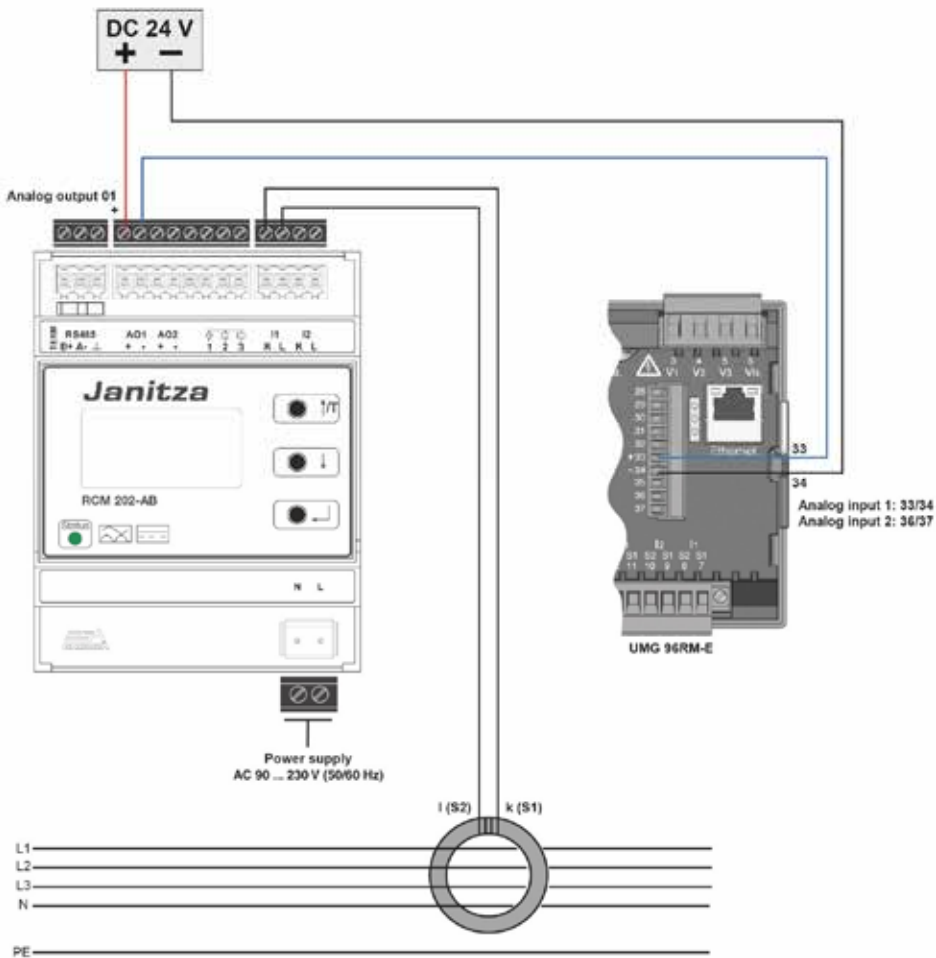
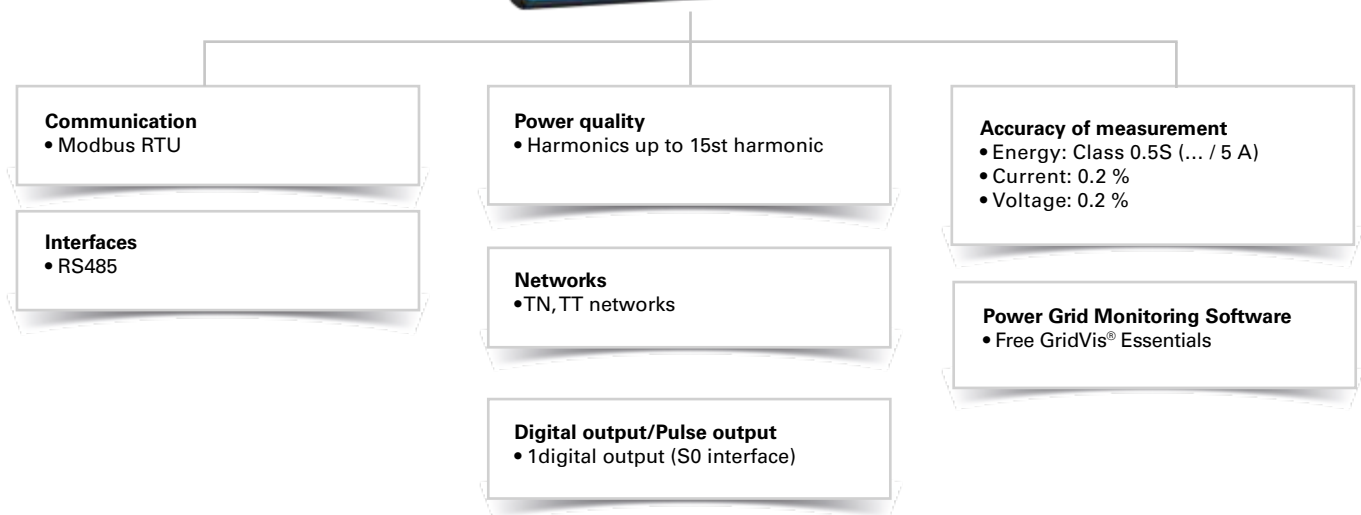


Fig.: Application example analog outputs and UMG 96RM-E

# UMG 96-S2

Universal energy measurement device



## Areas of application



- Measurement and checking of electrical characteristics and energy consumption in energy distribution systems
- Cost centre management
- Threshold value monitoring, measured value transducer for building management systems or PLC
- Monitoring of harmonics



UMG 96-S2 rear view

## Main features



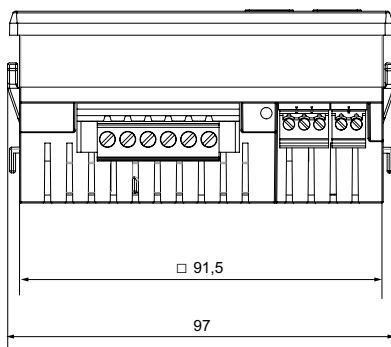
### Leistungsmerkmale

- 4 Voltage measurement inputs (300 V CATIII)
- 3 Current measurement inputs
- Continuous sampling of voltage and current measurement inputs
- Sampling frequency 8 kHz
- Transfer of the measured values via a serial interface
- Harmonics analysis up to 15th harmonic

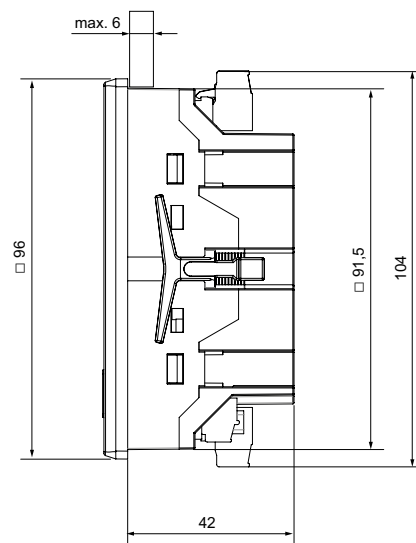


## Dimension diagrams

All dimensions in mm



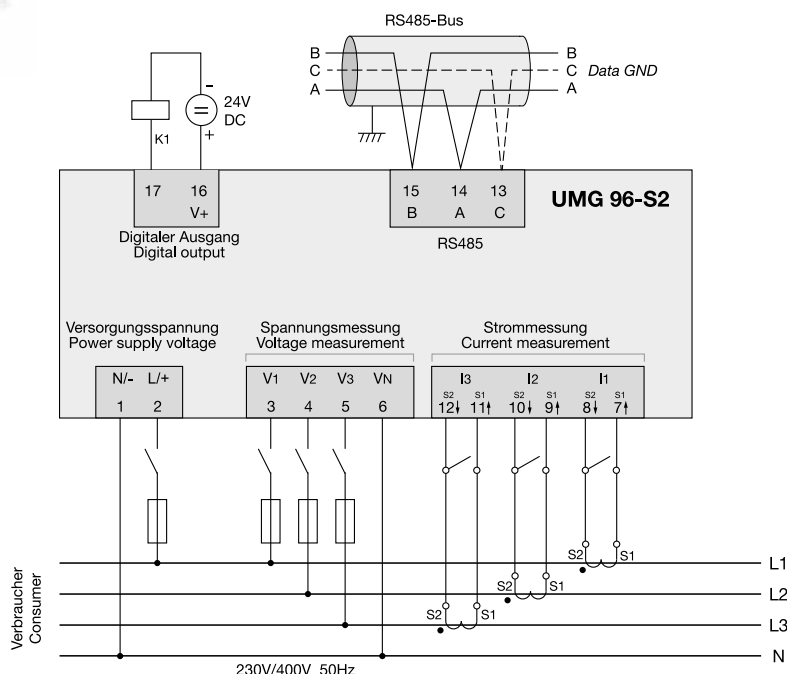
UMG 96-S2 bottom view



UMG 96-S2 side view



## Typical connection variant



## Device overview and technical data module

UMG 96-S2	52.34.002
<b>General information</b>	
Net weight (with attached connectors)	approx. 250 g (0.55 lb)
Packaging weight (including accessories)	approx. 500 g (1.1 lb)
Impact resistance	IK07 according to IEC 62262
<b>Transport and storage</b> (The following information applies to devices which are transported and stored in the original packaging.)	
Free fall	1 m (39.37 in)
Temperature	K55 (-25 °C to +70 °C) (-13 °F ..to 158 °F)
Relative humidity	0 to 90% RH
<b>Ambient conditions during operation</b>	
Use the UMG 96-S2 in a weather-protected, stationary application. Protection class II in accordance with IEC 60536 (VDE 0106, Part 1).	
Operating temperature range	K55 (-10 °C to +55 °C) (50 °F ..to 131 °F)
Relative humidity	0 to 75% RH
Operating altitude	0 to 2000 m above sea level
Degree of pollution	2
Installation position	discretionary
Ventilation	no external ventilation required
Protection against foreign bodies and water	
- Front	IP40 i.a.w. EN60529
- Rear	IP20 i.a.w. EN60529
- Front side with sealing	IP54 i.a.w. EN60529



## Device overview and technical data module

Supply voltage	
Nominal range	AC 90 V – 265 V (50/60 Hz) or DC 90 V – 250 V, 300 V CAT III
Operating range	± 10% of nominal range
Power consumption	max. 1.5 VA / 0.5 W
Internal fuse, not exchangeable	Type T1A / 250 V DC / 277 V AC according to IEC 60127
Recommended overcurrent protection device for the line protection	6-16 A (Char. B, IEC-/UL approval)

Voltage measurement	
Three-phase 4-conductor systems with nominal voltages up to	230 V/400 V (± 10%) according to IEC
Overvoltage category	300 V CAT III
Measurement voltage surge	4 kV
Fuse for the voltage measurement	1 – 10 A (with IEC-/UL approval)
Measuring range L-N	0 <sup>1)</sup> ... 300 Vrms (max. overvoltage 400 Vrms )
Measuring range L-L	0 <sup>1)</sup> ... 425 Vrms (max. overvoltage 620 Vrms )
Measurement range exceedance L-N	$U_{L-N} > 300 \text{ Vrms}$
Resolution	0.01 V
Crest factor	1.9 (related to the measurement range)
Impedance	3 MΩ/phase
Power consumption	approx. 0.1 VA
Sampling frequency	8 kHz
Frequency of the basic oscillation – resolution	45 Hz to 65 Hz – 0.01 Hz

Current measurement	
Rated current	x/1 and x/5 A
Metering range	0.005 .. 6 Arms
Measurement range exceedance	$I > 7 \text{ Arms}$
Crest factor (based on the rated current)	2
Resolution	1 mA (display 0.01 A) at .../5 A; 1/4 mA at .../1 A
Overvoltage category	300 V CAT II
Measurement voltage surge	2 kV
Power consumption	approx. 0.2 VA ( $R_i = 5 \text{ m}\Omega$ )
Overload 1 s	60 A (sinusoidal)
Sampling frequency	8 kHz

Serial interface	
RS485 - Modbus RTU/Slave	9.6 kbps, 19.2 kbps, 38.4 kbps

Digital output 1 digital output, semiconductor relay, not short-circuit proof.	
Switching voltage	max. 60 V DC
Switching current	max. 50 mAeff DC
Pulse output (energy pulse)	max. 12.5 Hz

Terminal connection capacity (supply voltage/voltage measurement/current measurement) Connectable conductor (Connect only one conductor per terminal!):	
Single core, multi-core, fine-stranded	0.2 – 4 mm <sup>2</sup> , AWG 28 – 12
Cable end sleeve (not insulated)	0.2 – 4 mm <sup>2</sup> , AWG 26 – 12
Cable end sleeve (insulated)	0.2 - 2.5 mm <sup>2</sup> , AWG 26 - 14
Tightening torque	0.4 - 0.5 Nm (3.54-4.43 lbf in)
Stripping length	7 mm (0.2756 in)

Terminal connection capacity (serial interface/digital interface)	
Single core, multi-core, fine-stranded	0.2 - 1.5 mm <sup>2</sup> , AWG 28 - 16
Cable end sleeve (not insulated)	0.2 - 1.5 mm <sup>2</sup> , AWG 26 - 16
Cable end sleeve (insulated)	0.2 - 1.5 mm <sup>2</sup> , AWG 26 - 16
Tightening torque	0.2 - 0.25 Nm (1.77-2.21lbf in)
Stripping length	7 mm (0.2756 in)

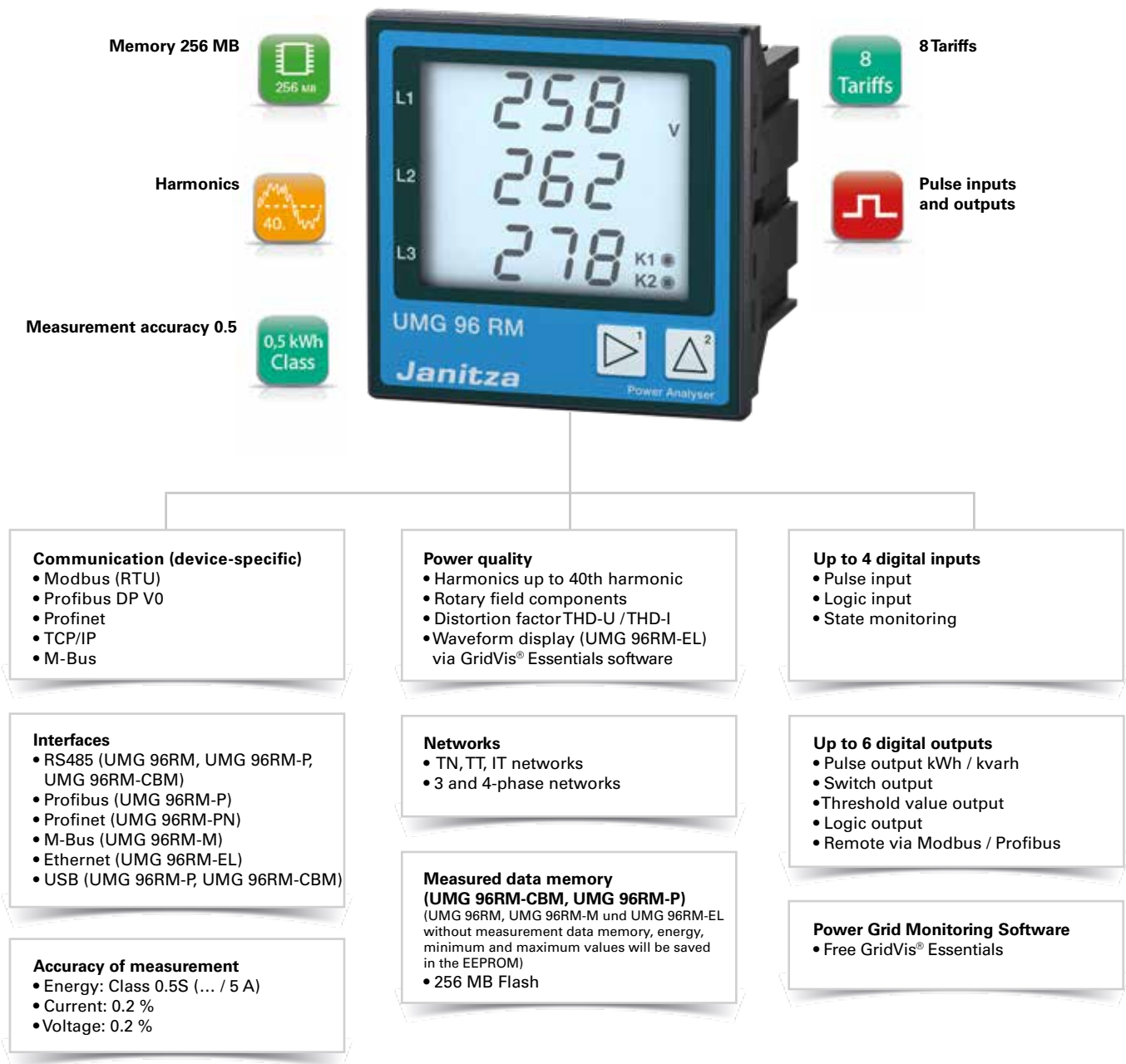
Firmware	
Firmware update	Please observe the operating instructions

Remark: For detailed technical information, please refer to the operation manual and Modbus address list.

<sup>1)</sup>The device only determines the measured values if voltage L1-N is greater than 20 Veff (4-conductor measurement) or voltage L1-L2 is greater than 34 Veff (3-conductor measurement) on voltage measurement input V1.

# UMG 96RM

## Multifunctional power analyzer





## Areas of application



- Measurement, monitoring and checking of electrical characteristics in energy distribution systems
- Recording of load profiles for energy management systems (e.g. ISO 50001)
- Acquisition of the energy consumption for cost centre analysis
- Measured value transducer for building management systems or PLC (Modbus)

## Main features

### Particular advantages

- Compact construction saves space and costs during installation
- Seamless and sustained recording thanks to large measured data memory or via the online data acquisition
- High data security and redundancy
- Comprehensive communications options and protocols
- Multifaceted, pre-defined reports for power quality and energy consumption analysis
- Simple report generation at the press of a button or automatically in accordance with defined time plans
- Precision measurement results provide an effective infrastructure as well as high production availability
- Generic Modbus profile: Arbitrary Modbus-capable devices and systems from other manufacturers can be incorporated and visualised in the monitoring solutions
- Long-term availability of the measurement devices guarantees simple retrofitting with system expansions

### Energy data acquisition & load profile

- Detailed acquisition of the energy data and the load profile
- More transparency in energy supply through energy analyses
- Safer design of the power distribution systems

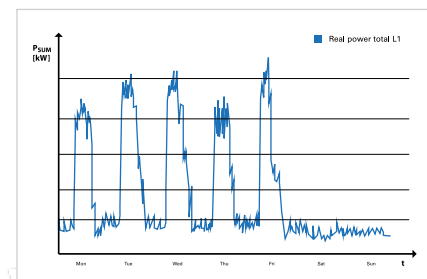


Fig.: Load profiles are the basis for energy management



### Cost centre analysis

- Determination of energy costs
- Breakdown and allocation of energy consumers

### Energy management systems (ISO 50001)

- Continuous increase in energy efficiency
- Cost reduction
- UMG 96RM series multifunctional power analysers are an important part of energy management systems

### Transparency of energy supply

- More transparency through a multi-stage, scalable measurement system
- Acquisition of individual events through continuous measurement with high resolution

	January	February	March	April	December	Total
HICA Water	2480	1240	160	380	240	4500 €
Boiler Heating	12 kWh	6 kWh	0,8 kWh	1,9 kWh	1,2 kWh	21,9 kWh
HICA Water Total	737	386	790	506	454	2873 €
	3,7 m <sup>3</sup>	1,9 m <sup>3</sup>	3,9 m <sup>3</sup>	2,5 m <sup>3</sup>	2,3 m <sup>3</sup>	14,3 m <sup>3</sup>
Hall 1 Final assembly	166	155	183	174	171	859 €
	831 kWh	776 kWh	920 kWh	871 kWh	856 kWh	4254 kWh
Hall 2 Painting	155	171	166	195	191	878 €
	776 kWh	856 kWh	831 kWh	980 kWh	956 kWh	4399 kWh
<b>Total</b>	<b>3538 €</b>	<b>1952 €</b>	<b>1299 €</b>	<b>1255 €</b>	<b>1056 €</b>	<b>9100 €</b>

Fig.: Cost centre analysis

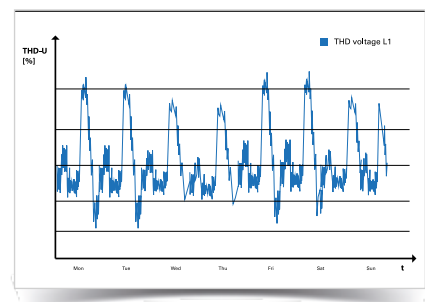


Fig.: Transparency of energy supply



### Power quality monitoring

- Notification of inadequate power quality
- Introduction of measures to address network problems
- Prevention of production downtimes
- Significantly longer service life for equipment
- Improved sustainability



### Measurement accuracy of 0.2 % (V), kWh class = 0.5S

- High sampling rate at 21.3 kHz
- Reliable measurement accuracy of 0.2 % (V)
- Effective energy class (kWh): 0.5S



### Energy meter with 8 tariffs, effective and reactive energy

- Energy measurement in 4 quadrants, each with 8 tariffs for effective and reactive energy
- Safe and precise acquisition of operational values for individual electrical loads



### Communications options: Ethernet, Profibus, Modbus, M-Bus, ...

- Numerous interfaces and protocols, guaranteeing an easy system connection (energy management system, PLC, SCADA, BMS)

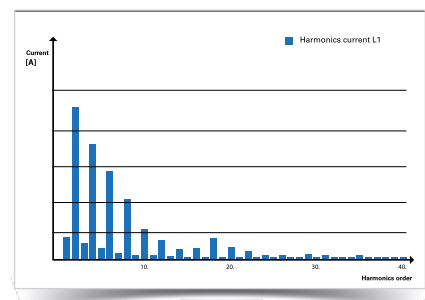


Fig.: Power quality monitoring (Harmonics analysis for the current up to 40th order harmonics)



**Large measurement data memory**

- Saving of measurement data possible over very long periods of time
- Recording freely user configurable



**Harmonics analyser**

- Harmonics analysis up to 40th harmonic
- Information about power quality, grid disturbances and possible "network polluters"

**Pluggable screw terminals**

- Convenient installation even where spaces are tight

**Backlight**

- Large, high-contrast LCD display with backlighting
- Very good readability and intuitive operation, even in poor lighting conditions

**Basic device**

- RS485 interface with Modbus protocol and 2 digital outputs enable quick and low-cost monitoring of power quality and energy consumption

**Profibus and digital IOs**

- The Profibus connection is used in systems where the UMG 96RM-P is to be incorporated into the automation environment (PLC controllers)



**M-Bus**

- The UMG 96RM-M can be simply and cost-effectively integrated into consumption data acquisition systems via the M-Bus connection.
- The M-Bus is primarily used for the acquisition of consumption data collection from various different consumption meters, such as water, gas, heat or electrical current.

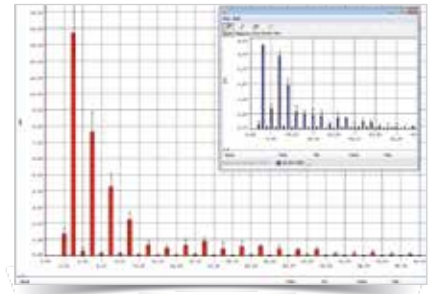


Fig.: GridVis® Power Grid Monitoring Software: Harmonics analysis



Fig.: Pluggable screw terminals for easy connection



Fig.: LCD Display backlight

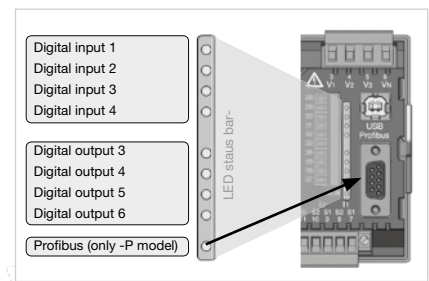


Fig.: LED status bar for the inputs and outputs (UMG 96RM-CBM and UMG 96RM-P)



### Ethernet (TCP/IP) with the UMG 96RM-EL

- Simple integration into the Ethernet (LAN) network
- Fast and reliable data communication

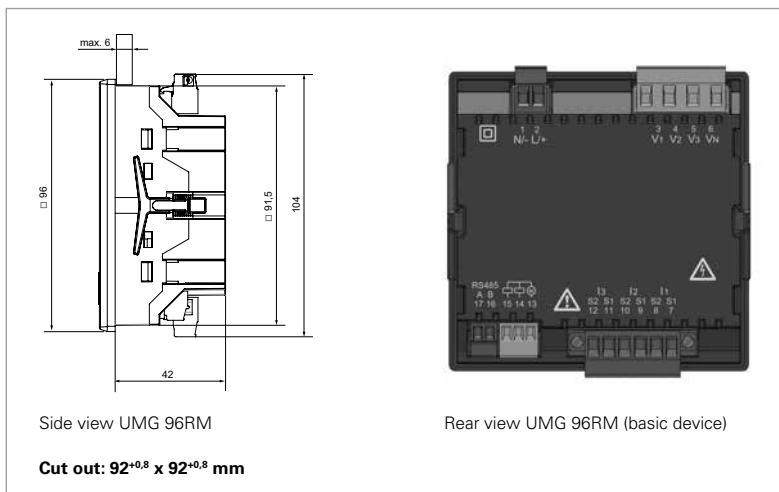
### 4th current transformer input

- Continuous monitoring of the N-conductor by means of the 4th current input
- Available with variants UMG 96RM-P and UMG 96RM-CBM



## Dimension diagrams

All dimensions in mm

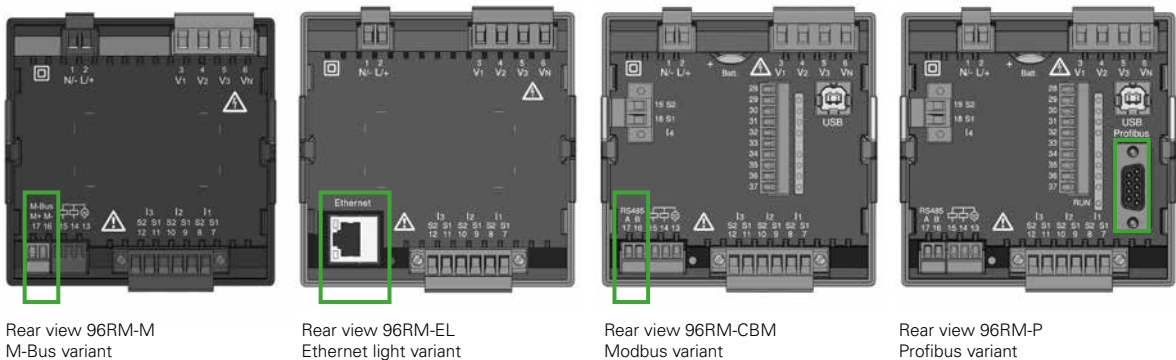


Side view UMG 96RM

Rear view UMG 96RM (basic device)

Rear view UMG 96RM-PN  
Profinet variant

**Cut out: 92<sup>+0,8</sup> x 92<sup>+0,8</sup> mm**



Rear view 96RM-M  
M-Bus variant

Rear view 96RM-EL  
Ethernet light variant

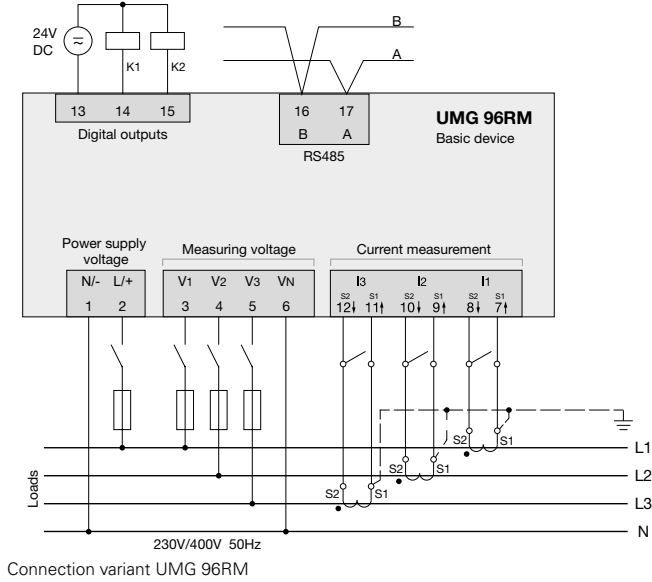
Rear view 96RM-CBM  
Modbus variant

Rear view 96RM-P  
Profibus variant

The illustrations shown here are examples. Further dimensional drawings and connection diagrams are available on request or can be viewed on our homepage.



## Typical connection



The illustration shown here is an example. Further connection diagrams are available on request or can be viewed on our homepage.



Fig.: Battery insertion on the rear (UMG 96RM-CBM and UMG 96RM-P)



Fig.: UMG 96RM-PN with Profinet interface



## Device overview and technical data

	UMG 96RM <sup>*1</sup>	UMG 96RM-M <sup>*1</sup>	UMG 96RM-EL <sup>*1</sup>	UMG 96RM-CBM <sup>*1</sup>	UMG 96RM-P <sup>*1</sup>	UMG 96RM-PN <sup>*1</sup>
Item no. (90–277 V AC/90–250 V DC)	52.22.061	52.22.069	52.22.068	52.22.066	52.22.064	52.22.090
Item no. (24–90 V AC/24–90 V DC)	52.22.070	52.22.073	52.22.072	52.22.067	52.22.065	52.22.091
Interfaces	RS485	M-Bus	Ethernet	RS485, USB	RS485, Profibus, USB	RS485, Ethernet, Profinet
<b>Protocols</b>						
Modbus RTU	•	-	-	•	•	•
Modbus TCP	-	-	•	-	-	•
Profibus DP V0	-	-	-	-	•	-
Profinet	-	-	-	-	-	•
M-Bus	-	•	-	-	-	-
DHCP or DCP	-	-	•	-	-	•
ICMP (Ping)	-	-	•	-	-	•
<b>Measurement data recording</b>						
Current measurement channels	3	3	3	4	4	4 (+2)
Memory (Flash)	-	-	-	256 MB	256 MB	-
Battery	-	-	-	Type CR2032 3 V, Li-Mn	Type CR2032 3 V, Li-Mn	-
Clock	-	-	-	•	•	-
<b>Digital inputs and outputs</b>						
Digital inputs	-	-	-	4	4	3 <sup>*3</sup>
Digital outputs (as switch or pulse output)	2	2	-	6	6	2 (+3) <sup>*3</sup>
<b>Mechanical properties</b>						
Device dimensions in mm (W x H x D) <sup>*2</sup>	96 x 96 x approx. 48	96 x 96 x approx. 48	96 x 96 x approx. 48	96 x 96 x approx. 78	96 x 96 x approx. 78	96 x 96 x approx. 78

Comment: For detailed technical information, please refer to the operation manual and the Modbus address list.

• = included - = not included

\*1 UL certification included.

\*2 Accurate device dimensions can be found in the operation manual.

\*3 Optional 3 digital inputs or outputs (no pulse output)

General	
Service life of backlight	40000 h (50% of the initial brightness)

Transport and storage	
The following information applies to devices which are transported or stored in the original packaging.	
Free fall	1 m
Temperature	K55 (-25 °C to +70 °C) (-13 °F ..to 158 °F)
Relative humidity	0 to 90% RH

Ambient conditions during operation	
The UMG 96RM is intended for weather-protected, stationary use. Protection class II in acc. with IEC 60536 (VDE 0106, Part 1).	
Rated temperature range	K55 (-10 °C to +55 °C) (14 °F ..to 131 °F)
Relative humidity	0 to 75% RH
Operating altitude	0 to 2000 m above sea level
Pollution degree	2
Installation position	any
Ventilation	forced ventilation is not required.
Protection against ingress of solid foreign bodies and water - Front - Rear - Front with seal	IP40 in acc. with EN60529 IP20 in acc. with EN60529 IP54 in acc. with EN60529

Supply voltage		
230 V option	Nominal range	90 V - 277 V (50/60 Hz) or DC 90 V - 250 V; 300 V CAT III
	Power consumption	max. 4.5 VA / 2 W (RM-M) max. 5.5 VA / 3 W (RM) max. 5 VA / 2 W (RM-EL) max. 6 VA / 3 W (RM-CBM) max. 7.5 VA / 4 W (RM-P) max. 8.5 VA / 5 W (RM-PN)
24 V option	Nominal range	24 V - 90 V AC / DC; 150 V CAT III
	Power consumption	max. 2.5 VA / 2 W (RM-M) max. 3.5 VA / 2 W (RM-EL) max. 4.5 VA / 3 W (RM) max. 5 VA / 3 W (RM-CBM) max. 6.5 VA / 5 W (RM-P) max. 7 VA / 5 W (RM-PN)
Operating range	±10% of nominal range	
Internal fuse, not replaceable	Type T1A / 250 V/277 V according to IEC 60127	
Recommended overcurrent protection device for line protection (certified under UL)	230 V option: 6 - 16 A 24 V option: 1 - 6 A (Char. B)	

Terminal connection capacity (supply voltage)	
Connectable conductors. Only one conductor can be connected per terminal!	
Single core, multi-core, fine-stranded	0.2 - 2.5 mm <sup>2</sup> , AWG 26 - 12
Terminal pins, core end sheath	0.2 - 2.5 mm <sup>2</sup>
Tightening torque	0.4 - 0.5 Nm (3.54 - 4.43 lbf in)
Stripping length	7 mm (0.2756 in)

Voltage measurement	
Three-phase 4-conductor systems with rated voltages up to	277 V/480 V (±10%)
Three-phase 3-conductor systems, ungrounded, with rated voltages up to	IT 480 V (±10%)
Overvoltage category	300 V CAT III
Measurement voltage surge	4 kV
Metering range L-N	0 <sup>1)</sup> to 300 V <sub>rms</sub> (max. overvoltage 520 V <sub>rms</sub> )
Metering range L-L	0 <sup>1)</sup> to 520 V <sub>rms</sub> (max. overvoltage 900 V <sub>rms</sub> )
Resolution	0.01 V
Crest factor	2.45 (related to the measurement range)
Impedance	3 MΩ/phase
Power consumption	approx. 0.1 VA
Sampling rate	21.33 kHz (50 Hz), 25.6 kHz (60 Hz) for each measurement channel
Frequency of the fundamental oscillation - Resolution	45 Hz to 65 Hz 0.01 Hz

<sup>1)</sup> The UMG 96RM can only determine measured values if a voltage L1-N greater than 20 V<sub>eff</sub> (4-wire measurement) or a voltage L1-L2 greater than 34 V<sub>eff</sub> (3-wire measurement) is applied at the voltage measurement input V1.

Current measurement	
Rated current	5 A
Metering range	0 to 6 A <sub>rms</sub>
Crest factor	1.98
Resolution	0.1 mA (display 0.01 A)
Overvoltage category	300 V CAT II
Measurement voltage surge	2 kV
Power consumption	approx. 0.2 VA (R <sub>i</sub> = 5 mΩ)
Overload for 1 sec.	120 A (sinusoidal)
Sampling rate	21.33 kHz (50 Hz), 25.6 kHz (60 Hz) for each measurement channel

Firmware	
Firmware update	Please observe the operating instructions

Remark: For detailed technical information, please refer to the operation manual and Modbus address list.

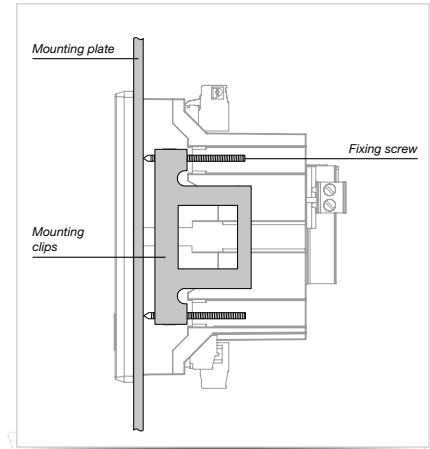


Fig.: The fastening into a switchboard is implemented via the side-mounted fastening clamps (UMG 96RM-P / UMG 96RM-CBM)

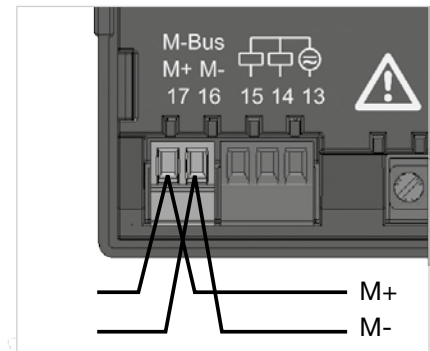


Fig.: M-Bus interface with 2-pole plug contact



Fig.: 2-pole plug contact with cable connection (cable type: 2 x 0.75 mm<sup>2</sup>) via twin core end sheaths

# UMG 96 RM-E

Multifunctional power analyzer with Ethernet and RCM



Memory 256 MB



Residual current measurement



Ethernet-Modbus gateway



Alarm management



Homepage



BACnet (optional)

**Communication**

- Modbus (RTU, TCP, Gateway)
- TCP/IP
- HTTP (configurable homepage)
- FTP (file transfer)
- SNMP
- NTP (time synchronisation)
- SMTP (email function)
- DHCP
- SNTP
- TFTP
- BACnet (optional)

**Interfaces**

- RS485
- Ethernet

**Accuracy of measurement**

- Energy: Class 0.5S (... / 5 A)
- Current: 0.2 %
- Voltage: 0.2 %

**Power quality**

- Harmonics up to 40th harmonic
- Rotary field components
- Distortion factor THD-U / THD-I

**Networks**

- TN, TT, IT networks
- 3 and 4-phase networks
- Up to 4 single-phase networks

**Measured data memory**

- 256 MB Flash

**Temperature measurement**

- PT100, PT1000, KTY83, KTY84

**2 digital outputs**

- Pulse output kWh / kvarh
- Switch output
- Threshold value output
- Logic output
- Remote via Modbus / Profibus

**3 digital inputs/outputs**

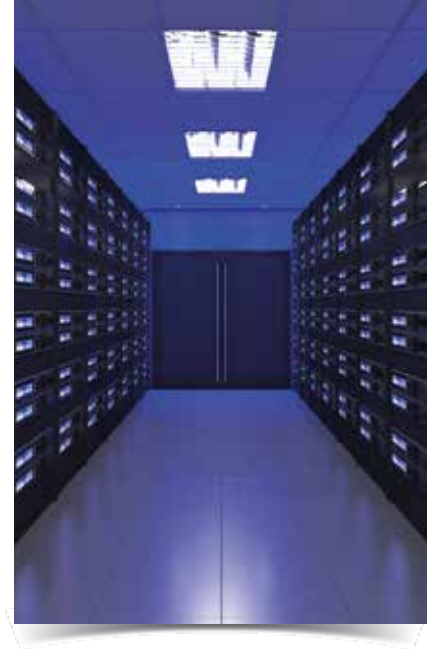
- Usable as either inputs or outputs

**2 analogue inputs**

- Analogue, temperature or residual current input (RCM)

**Power Grid Monitoring Software**

- Free GridVis® Essentials



## Areas of application



- Measurement, monitoring and checking of electrical characteristics in energy distribution systems
- Recording of load profiles in energy management systems (e.g. ISO 50001)
- Acquisition of the energy consumption for cost centre analysis
- Measured value transducer for building management systems or PLC (Modbus)
- Monitoring of power quality characteristics, e.g. harmonics up to 40th harmonic
- Residual current monitoring (RCM)

## Main features

### Universal meter

- Operating current monitoring for general electrical parameters
- High transparency through a multi-stage and scalable measurement system in the field of energy measurement
- Acquisition of events through continuous measurement with 200 ms high resolution



### RCM device

- Continuous monitoring of residual currents (Residual Current Monitor, RCM)
- Alarming in case a preset threshold fault current reached
- Near-realtime reactions for triggering countermeasures
- Permanent RCM measurement for systems in permanent operation without the opportunity to switch off

### Energy measurement device

- Continuous acquisition of the energy data and load profiles
- Essential both in relation to energy efficiency and for the safe design of power distribution systems



### Harmonics analyser / event recorder

- Analysis of individual harmonics for current and voltage
- Prevention of production downtimes
- Significantly longer service life for equipment
- Rapid identification and analysis of power quality fluctuations by means of user-friendly tools (GridVis®)

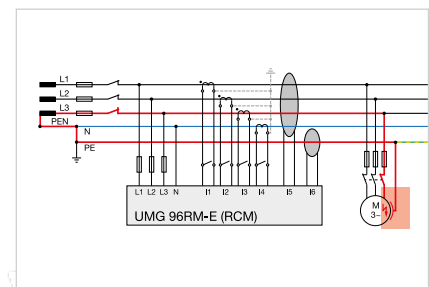


Fig.: UMG 96RM-E with residual current monitoring via measuring inputs I5 / I6

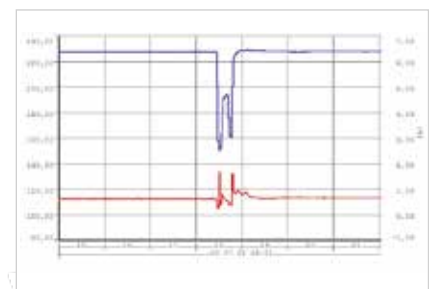


Fig.: Event logger: Voltage dip in the low voltage distribution system



7  
Tariffs

**Extensive selection of tariffs**

- 7 tariffs each for effective energy (consumption, delivery and without backstop)
- 7 tariffs each for reactive energy (inductive, capacitive and without backstop)
- 7 tariffs for apparent energy
- L1, L2 and L3, for each phase

**Highest possible degree of reliability**

- Continuous leakage current measurement
- Historical data: Long-term monitoring of the residual current allows changes to be identified in good time, e.g. insulation faults
- Time characteristics: Recognition of time relationships
- Prevention of neutral conductor carryover
- RCM threshold values can be optimized for each individual case: Fixed, dynamic and stepped RCM threshold value
- Monitoring of the CGP (central ground point) and the sub-distribution panels

**Analysis of fault current events**

- Event list with time stamp and values
- Presentation of fault currents with characteristic and duration
- Reproduction of phase currents during the fault current surge
- Presentation of the phase voltages during the fault current surge

**Analysis of the harmonic fault current components**

- Frequencies of the fault currents (fault type)
- Current peaks of the individual frequency components in A and %
- Harmonics analysis up to 40th harmonic
- Maximum values with real-time bar display

**Digital IOs**

- Extensive configuration of IOs for intelligent integration, alarm and control tasks

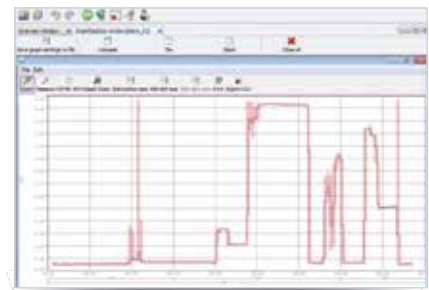


Fig.: Continuous leakage current measurement

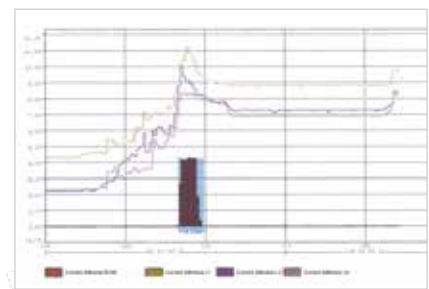


Fig.: Analysis of fault current events

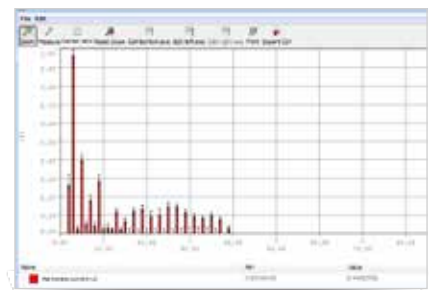


Fig.: Analysis of the harmonic fault current components



### Ethernet (TCP/IP)- / Homepage- / Ethernet-Modbus gateway functionality

- Simple integration into the network
- More rapid and reliable data transfer
- Modern homepage
- World-wide access to measured values by means of standard web browsers via the device's inbuilt homepage
- Access to measurement data via various channels
- Reliable saving of measurement data possible over a very long periods of time in the 256 MByte measurement data memory
- Connection of Modbus slave devices via Ethernet-Modbus gateway



Fig.: Ethernet-Modbus gateway functionality



### Measuring device homepage

- Webserver on the measuring device, i.e. device's own homepage
- Remote operation of the device display via the homepage
- Comprehensive measurement data incl. PQ
- Online data directly available via the homepage, historic data optional via the APP measured value monitor, 51.00.246

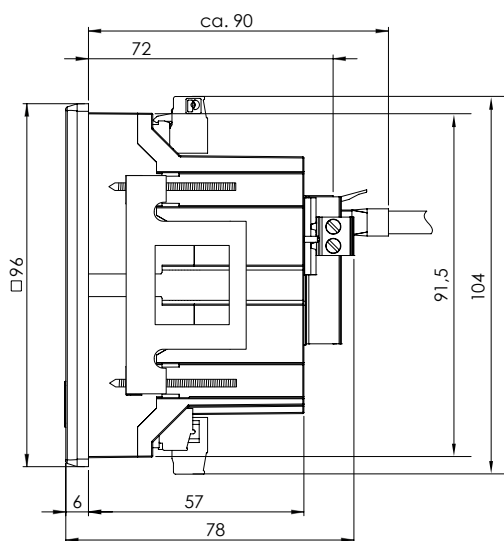


Fig.: Illustration of the online data via the device's inbuilt homepage



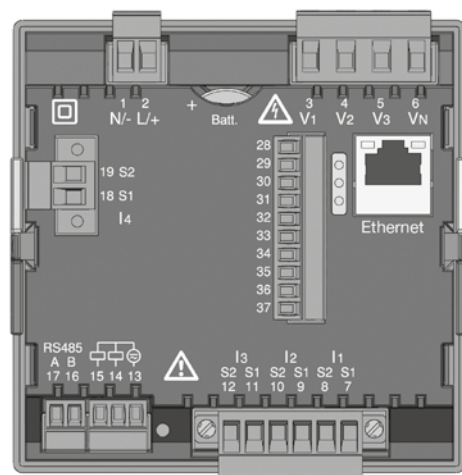
### Dimension diagrams

All dimensions in mm



Side view

Cut out: 92<sup>+0,8</sup> x 92<sup>+0,8</sup> mm



Rear view



## Typical connection

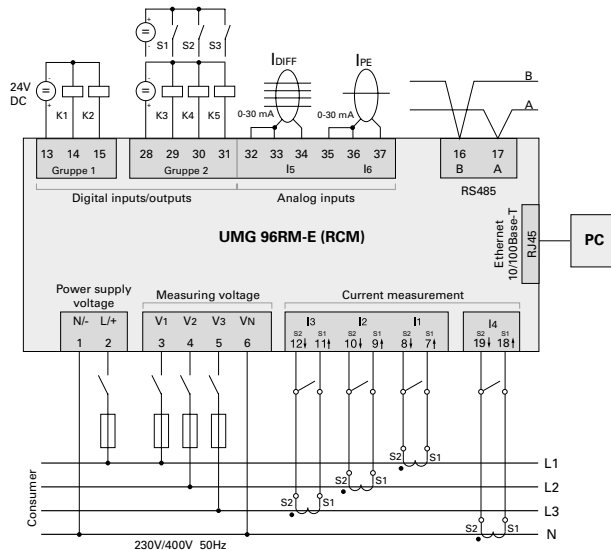


Fig.: Connection example with temperature and residual current measurement

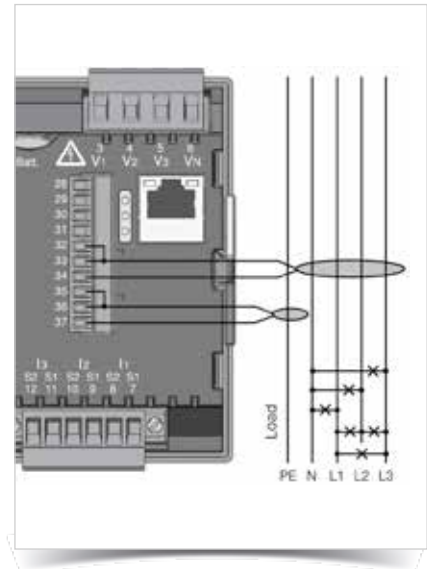


Fig.: Connection example residual current measurement and PE monitoring



## Device overview and technical data

UMG 96RM-E	
Item no. (90–277 V AC / 90–250 V DC)	52.22.062
Item no. (24-90 V AC / 24-90 V DC)	52.22.063
BACnet communication	52.22.081
<b>General</b>	
Net weight (with attached connectors)	approx. 370 g (0.82 lb)
Package weight (incl. accessories)	approx. 950 g (2.09 lb)
Battery	Lithium battery CR2032, 3V (approval i.a.w. UL 1642)
Service life of backlight	40000 h (after this period of time the background lighting efficiency will reduce by approx. 50 %)
<b>Transport and storage</b>	
The following information applies to devices which are transported or stored in the original packaging.	
Free fall	1m
Temperature	K55 (-25° C to +70° C) (-13 °F ..to 158 °F)
Relative humidity	0 to 90% RH

<b>Ambient conditions during operation</b>	
The UMG 96RM is intended for weather-protected, stationary use. Protection class II in acc. with IEC 60536 (VDE 0106, Part 1).	
Operating temperature range	K55 (-10° C to +55° C) (14 °F ..to 131 °F)
Relative humidity	0 to 75% RH
Operating altitude	0 to 2000 m above sea level
Degree of pollution	2
Mounting position	vertical
Ventilation	forced ventilation is not required.
Protection against ingress of solid foreign bodies and water - Front - Rear - Front with seal	IP40 in acc. with EN60529 IP20 in acc. with EN60529 IP54 in acc. with EN60529

<b>Supply voltage</b>		
Option 230V	Nominal range	90 V - 277 V (50/60 Hz) or DC 90 V - 250 V; 300 V CAT III
	Power consumption	max. 7.5 VA / 4 W
Option 24V	Nominal range	24 V - 90 V AC / DC; 150 V CAT III
	Power consumption	max. 7.5 VA / 5 W
Operating range	±10% of nominal range	
Internal fuse, not replaceable	Type T1A / 250 V/277 V according to IEC 60127	
Recommended overcurrent protection device for line protection (certified under UL)	Option 230V: 6 - 16A Option 24V: 1 - 6A (Char. B)	

Recommendation for a maximum number of devices on a circuit breaker:

Option 230V: Circuit breaker B6A: max. 4 devices / Circuit breaker B16A: max. 11 devices

Option 24V : Circuit breaker B6A: max. 3 devices / Circuit breaker B16A: max. 9 devices

<b>Digital outputs</b>	
2 and 3 optional additional digital outputs, semiconductor relay, not short-circuit proof	
Switching voltage	Max. 33 V AC, 60 V DC
Switching current	max. 50 mAeff AC/DC
Response time	10/12 periods + 10 ms *
Pulse output (energy pulses)	max. 50 Hz

\* Response time, e.g. at 50 Hz: 200 ms + 10 ms = 210 ms

<b>Digital inputs</b>	
3 optional additional digital outputs, semiconductor relay, not short-circuit proof	
Maximum counter frequency	20 Hz
Input signal present	18 V to 28 V DC (typical 4 mA)
Input signal not present	0 to 5 V DC, current less than 0.5 mA

<b>Temperature measurement input</b>	
2 optional inputs	
Update time	1 second
Connectable sensors	PT100, PT1000, KTY83, KTY84
Total burden (sensor + cable)	max. 4 kOhm

Sensor type	Temperature range	Resistor range	Measurement uncertainty
KTY83	-55° C ... +175° C (-67 °F ..to 347 °F)	500 Ohm to 2.6 kOhm	±1.5% rng
KTY84	-40° C ... +300° C (-40 °F ..to 572 °F)	350 Ohm to 2.6 kOhm	±1.5% rng
PT100	-99° C ... +500° C (-146.2 °F ..to 932 °F)	60 Ohm to 180 Ohm	±1.5% rng
PT1000	-99° C ... +500° C (-146.2 °F ..to 932 °F)	600 Ohm to 1.8 kOhm	±1.5% rng



<b>Cable length (digital inputs / outputs, temperature measurement input)</b>	
Up to 30 m	unshielded
More than 30 m	shielded

Serial interface	
RS485 to Modbus RTU/Slave	9.6 kbps, 19.2 kbps, 38.4 kbps, 57.6 kbps, 115.2 kbps
Stripping length	7 mm

Voltage measurement	
Three-phase 4-conductor systems with rated voltages up to	277 V/480 V ( $\pm 10\%$ )
Three-phase 3-conductor systems, unearthed, with rated voltages up to	IT 480V ( $\pm 10\%$ )
Overvoltage category	300 V CAT III
Measurement voltage surge	4 kV
Metering range L-N	0 <sup>1)</sup> to 300 V <sub>rms</sub> (max. overvoltage 520 V <sub>rms</sub> )
Metering range L-L	0 <sup>1)</sup> to 520 V <sub>rms</sub> (max. overvoltage 900 V <sub>rms</sub> )
Resolution	0.01 V
Crest factor	2.45 (related to the measurement range)
Impedance	3 M $\Omega$ /phase
Power consumption	approx. 0.1 VA
Sampling rate	21.33 kHz (50 Hz), 25.6 kHz (60 Hz) for each measurement channel
Frequency of the fundamental oscillation	45 Hz to 65 Hz
- Resolution	0.01 Hz

<sup>1)</sup> The UMG 96RM-E can only determine measured values if a voltage L1-N greater than 20 Veff (4-wire measurement) or a voltage L1-L2 greater than 34 Veff (3-wire measurement) is applied at the voltage measurement input V1.

Current measurement I1 - I4	
Rated current	5 A
Metering range	0 to 6 A <sub>rms</sub>
Crest factor	1.98
Resolution	0.1 mA (display 0.01 A)
Overvoltage category	300 V CAT II
Measurement voltage surge	2 kV
Power consumption	approx. 0.2 VA (Ri = 5 m $\Omega$ )
Overload for 1 sec.	120 A (sinusoidal)
Sampling rate	20 kHz

Residual current monitoring I5 / I6	
Rated current	30 mA <sub>rms</sub>
Metering range	0 to 40 mA <sub>rms</sub>
Triggering current	50 $\mu$ A
Resolution	1 $\mu$ A
Crest factor	1.414 (related to 40 mA)
Burden	4 Ohm
Overload for 1 sec.	5 A
Sustained overload	1 A
Overload for 20 ms	50 A
Residual current monitoring	as per IEC/TR 60755 (2008-01), Type A  Type B 

Ethernet connection	
Connection	RJ45
Functions	Modbus gateway, embedded web server (HTTP)
Protocols	TCP/IP, DHCP-Client (BootP), Modbus/TCP (Port 502), ICMP (Ping), NTP, Modbus RTU over Ethernet (Port 8000), FTP, SNMP

Terminal connection capacity (supply voltage)	
Connectable conductors. Only one conductor can be connected per terminal!	
Single core, multi-core, fine-stranded	0.2 - 2.5 mm <sup>2</sup> , AWG 26 - 12
Terminal pins, core end sheath	0.2 - 2.5 mm <sup>2</sup>
Tightening torque	0.4 - 0.5 Nm (3.54 - 4.43 lbf in)
Stripping length	7 mm (0.2756 in)

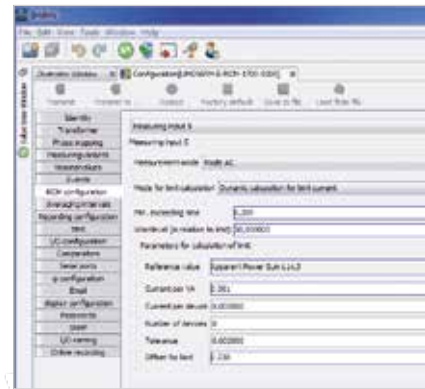


Fig.: RCM configuration, e.g. dynamic threshold value formation, for load-dependent threshold value adaptation



Fig.: Residual current transformer for the acquisition of residual currents. Wide range with different configurations and sizes allow use in almost all applications

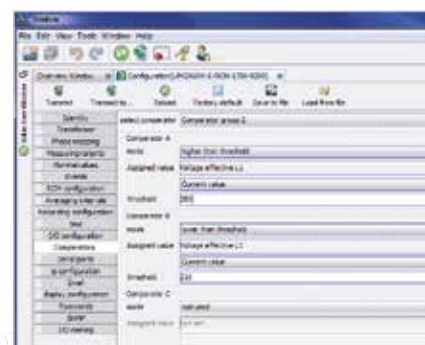


Fig.: GridVis® Power Grid Monitoring Software, configuration menu

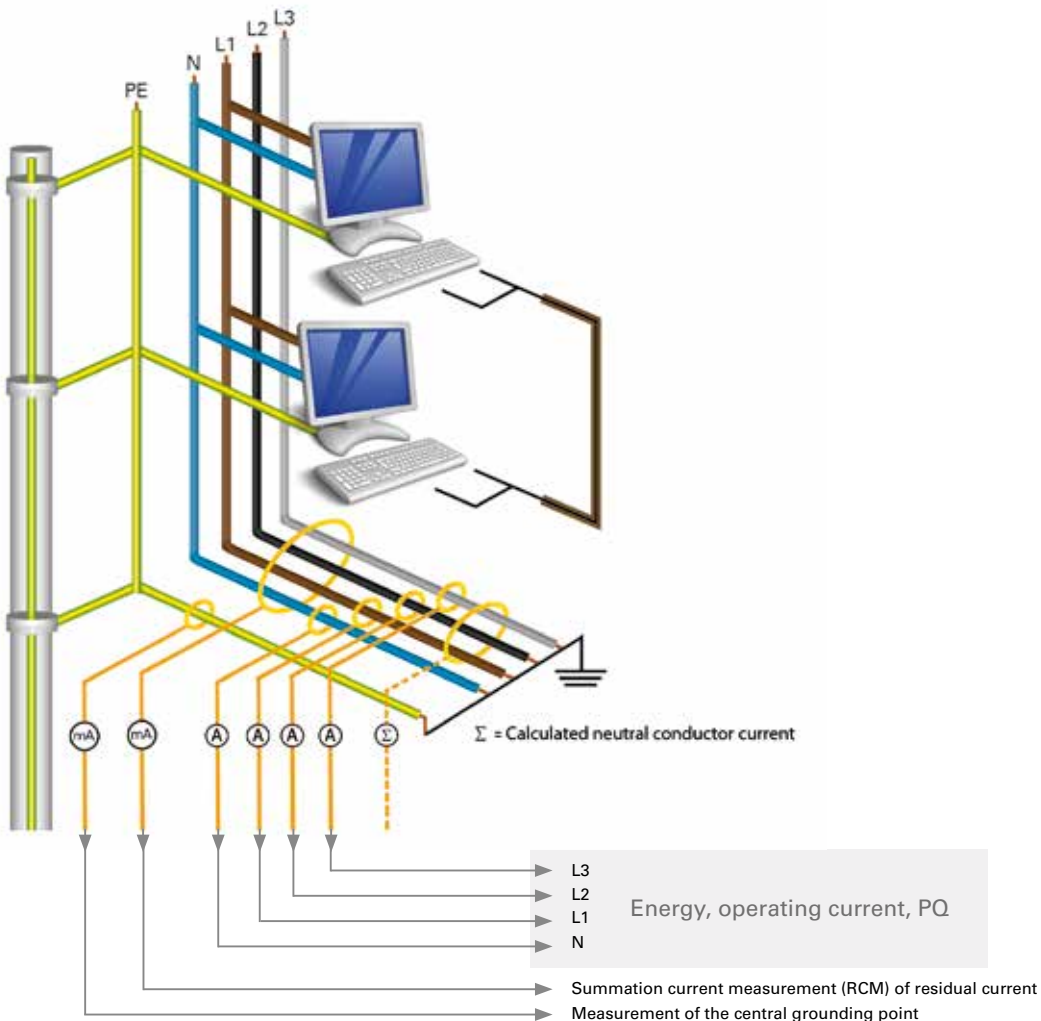
<b>Terminal connection capacity (voltage and current measurement)</b>		
Connectable conductors. Only one conductor can be connected per terminal!		
	<b>Current</b>	<b>Voltage</b>
Single core, multi-core, fine-stranded	0.2 - 2.5 mm <sup>2</sup> , AWG 26-12	0.08 - 4.0 mm <sup>2</sup> , AWG 28-12
Terminal pins, core end sheath	0.2 - 2.5 mm <sup>2</sup>	0.2 - 2.5 mm <sup>2</sup>
Tightening torque	0,4 - 0,5 Nm (3.54 - 4.43 lbf in)	0,4 - 0,5 Nm (3.54 - 4.43 lbf in)
Stripping length	7 mm (0.2756 in)	7 mm (0.2756 in)

<b>Terminal connection capacity (residual current and temperature measurement inputs and digital inputs/outputs)</b>	
Rigid/flexible	0.14 - 1.5 mm <sup>2</sup> , AWG 28-16
Flexible with core end sheath without plastic sleeve	0.20 - 1.5 mm <sup>2</sup>
Flexible with core end sheath with plastic sleeve	0.20 - 1.5 mm <sup>2</sup>
Tightening torque	0,20 - 0,25 Nm (1.77 - 2.21 lbf in)
Stripping length	7 mm (0.2756 in)

<b>Terminal connection capacity (serial interface)</b>	
Single core, multi-core, fine-stranded	0.20 - 1.5 mm <sup>2</sup>
Terminal pins, core end sheath	0.20 - 1.5 mm <sup>2</sup>
Tightening torque	0,20 - 0,25 Nm (1.77 - 2.21 lbf in)
Stripping length	7 mm (0.2756 in)

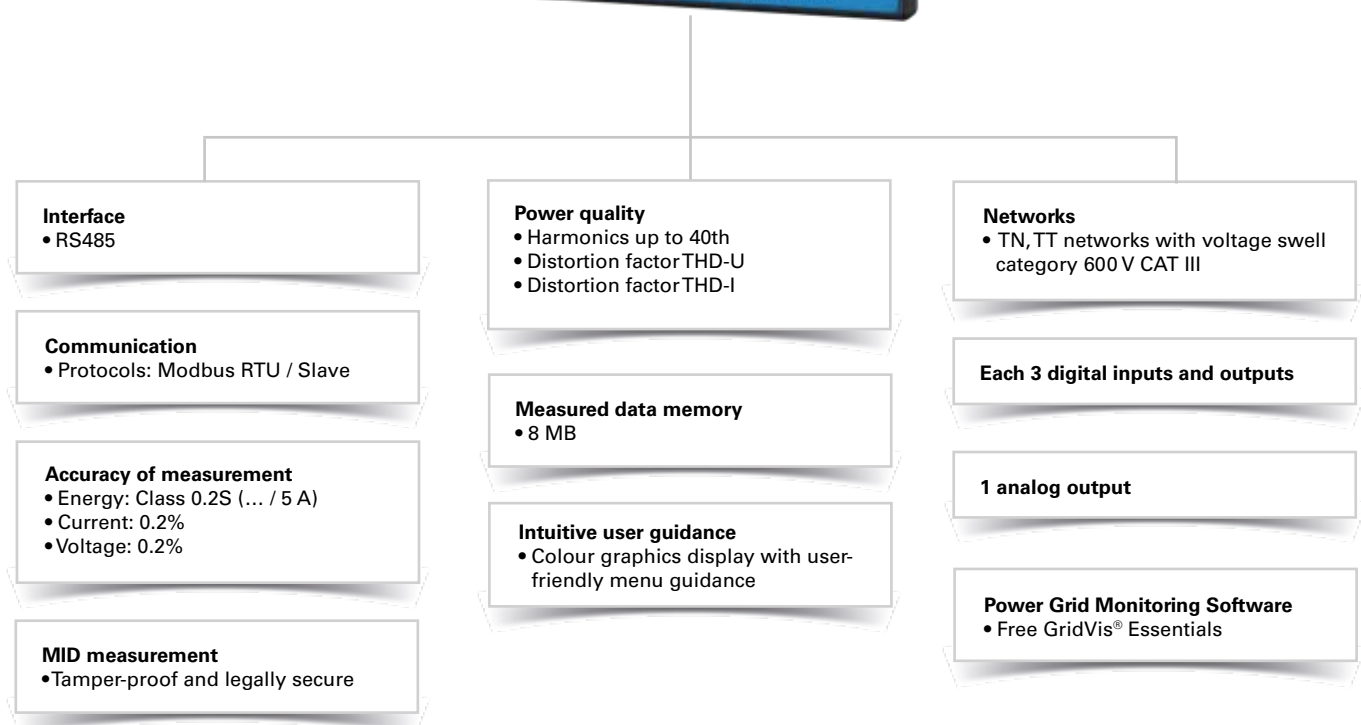
<b>Firmware</b>	
Firmware update	Please observe the operating instructions

Remark: For detailed technical information, please refer to the operation manual and Modbus address list.



# UMG 96-PA

Modular energy measurement device (MID)





## Areas of application



- Measurement, monitoring and checking of electrical characteristics in energy distribution systems
- Recording of load profiles in energy management systems (e.g. ISO 50001)
- Acquisition of the energy consumption for cost centre analysis
- Measured value transducer for building management systems or PLC (Modbus)
- As MID variant, suitable for accounting applications
- Optional module-based extension for residual and leakage current measurement
- Near-realtime reactions for triggering countermeasures
- Permanent RCM measurement for systems in permanent operation without the opportunity to switch off

## Main features



### Power quality

- Harmonics analysis up to 40th harmonic
- Distortion factor THD-U / THD-I
- Minimum and maximum values
- Measurement of positive, negative and zero sequence component

### Features

- 3 Voltage measurement inputs (600 V CATIII)
- 3 Current measurement inputs
- Continuous sampling of the voltage and current measurement inputs
- Measurement of the reactive distortion power
- Sampling rate 8.33 kHz
- Transfer of the measured values via a serial interface



### Extension of functions by add-on modules

- 2 analogue inputs – can be selected as 0–20 mA analogue inputs or as RCM measuring inputs with detection of cable breaks and additional temperature measurement
- Module – selectable with Ethernet interface
- Continuous monitoring of residual currents (Residual Current Monitoring, RCM)



Fig.: UMG 96-PA energy measurement device



Fig.: UMG 96-PA incl. module with Ethernet connection



### Digital IOs

- Additional application options with comprehensive peripherals (three digital inputs and outputs and an analogue output)
- Extensive configuration of IOs for intelligent integration for monitoring of limit values and message upon exceedance



### User-friendly, colour graphical display with intuitive user guidance

- High resolution colour graphical display 320 x 240 pixels, 6 buttons
- User-friendly, self-explanatory and intuitive operation
- Illustration of measured values in numeric form, as a bar graph or line graph



### MID-compliant measurement (only UMG 96-PA-MID+)

- Certified and tamper-proof measurement
- Legally secure accounting & energy acquisition (EEG [German renewable energy sources] law, StromStG [German electricity tax law])
- Fulfilment of legal stipulations

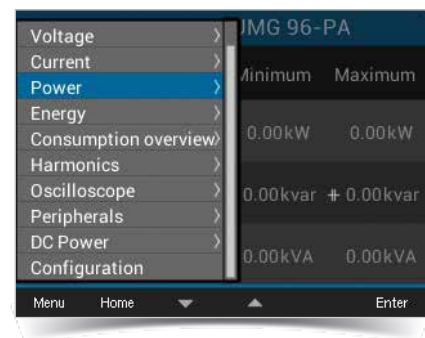
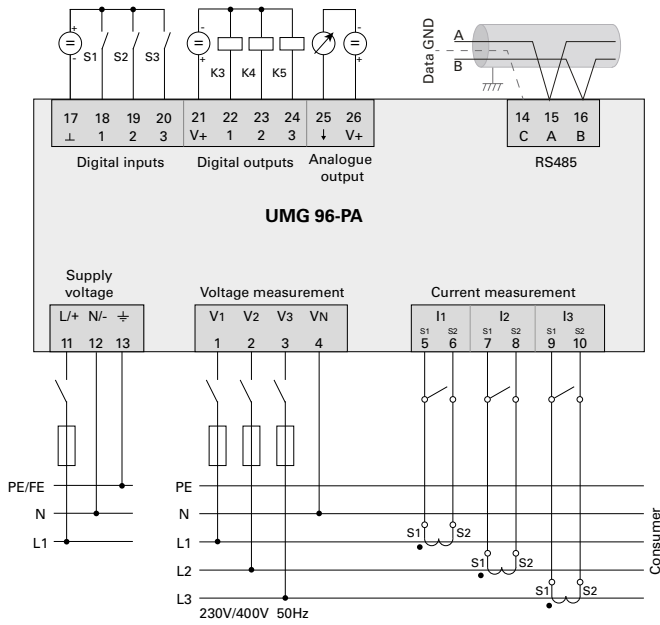


Fig.: UMG 96-PA colour graphics display

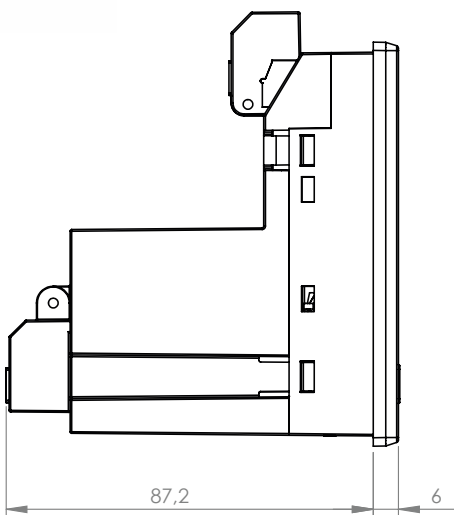


## Typical connection variant

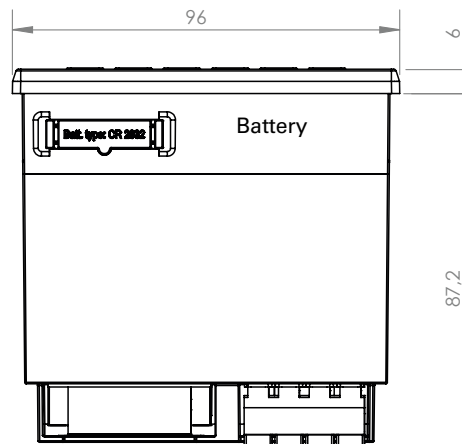


## Dimension diagrams

All dimensions in mm



Side view



View from below

Cut-out size:  $92^{+0,8} \times 92^{+0,8}$  mm



## Device overview and technical data, basic device

Basic device <u>without</u> MID	UMG 96-PA
Item no. (90–277 V AC / 90–250 V DC)	52.32.001
Item no. (24-90 V AC / 24-90 V DC)	52.32.002
Basic device <u>with</u> MID and national certification according to PTB-A 50.7	UMG 96-PA-MID+
Item no. (90–277 V AC / 90–250 V DC)	52.32.004

General	
Net weight (with attached plug-in connectors)	approx. 250 g (0.55 lbs)
Package weight (incl. accessories)	approx. 500 g (1.1 lbs)
Battery	Type Lithium CR2032, 3 V, (UL 1642 approved)
Data memory	64 MB
Backlight service life	40000 h (backlight reduces to approx. 50% over this period)
Impact resistance	IK07 according to IEC 62262

Transport and storage	
The following information applies to devices that are transported or stored in their original packaging.	
Free fall	1 m (39.37 in)
Temperature	-25 °C (-13 °F) to +70 °C (158 °F)
Relative air humidity (non-condensing)	0 to 90% RH

Environmental conditions during operation	
Install the device in a weather-protected and stationary location. Protection class II according to IEC 60536 (VDE 0106, Part 1).	
Rated temperature range	-10 °C (14 °F) ... +55 °C (131 °F)
Relative air humidity (non-condensing)	0 to 75% RH
Operating elevation	0 .. 2000 m (6562 ft) above sea level
Pollution degree	2
Mounting orientation	As desired
Ventilation	No forced ventilation required.
Protection against foreign matter and water	
- Front	IP40 according to EN60529
- Rear	IP20 according to EN60529
- Front with seal	IP54 according to EN60529 (mandatory for the MID device!)

Supply voltage		
Option 230 V	Nominal range	AC 90 V - 277 V (50/60 Hz) or DC 90 V - 250 V, 300 V CATIII
	Power consumption	max. 4.5 VA / 2 W
Option 24 V *	Nominal range	AC 24 V - 90 V (50/60Hz) or DC 24 V - 90 V, 150 V CATIII
	Power consumption	max. 4.5 VA / 2 W
Operating range	±10% of nominal range	
Internal fuse, not replaceable	Type T1A / 250 V DC / 277 V AC according to IEC 60127	
Recommended overcurrent protective device for the line protection (UL approval)	Option 230 V: 6 - 16 A (Char. B) Option 24 V *: 1 - 6 A (Char. B)	

\* The 24 V option only applies to the UMG 96-PA!

Recommendation for the maximum number of devices on a line circuit breaker:  
 Option 230 V: Line circuit breaker B6A: max. 4 devices / line circuit breaker B16A: max. 11 devices  
 Option 24 V: Line circuit breaker B6A: max. 3 devices / line circuit breaker B16A: max. 9 devices

<b>Voltage measurement</b>	
3-phase 4-conductor systems with rated voltages up to	417 V / 720 V (+-10%) according to IEC 347 V / 600 V (+-10%) according to UL MID: see table „ <b>Technical data for the MID+ certified measurement device</b> “.
Three-phase 3-conductor system with rated voltages up to	600 V (+-10%)
Single-phase 2-conductor system with rated voltages up to	480 V (+-10%)
Overvoltage category	600 V CAT III
Rated surge voltage	6 kV
Protection of the voltage measurement	1 - 10 A (with IEC/UL approval)
Measuring range L-N	0 <sup>1)</sup> ... 600 Vrms (max. overvoltage 800 Vrms)
Measuring range L-L	0 <sup>1)</sup> ... 1040 Vrms (max. overvoltage 1350 Vrms)
Resolution	0.01 V
Crest factor	2.45 (related to the measuring range)
Impedance	3 MΩ/phase
Power consumption	approx. 0.1 VA
Sampling frequency	8.13 kHz
Frequency of the fundamental oscillation	45 Hz .. 65 Hz
- Resolution	0.01 Hz
Fourier analysis	1st-40th harmonic

1) The device only determines measured values if a voltage L1-N of greater than 20 Veff (4-conductor measurement) or a voltage L1-L2 of greater than 34 Veff (3-conductor measurement) is applied to voltage measurement input V1.

<b>Current measurement</b>	
Nominal current	5 A
Measurement range	0.005 .. 6 Arms
Crest factor	2 (relative to 6 Arms)
Overvoltage category	300 V CAT II
Rated surge voltage	2.5 kV
Power consumption	approx. 0.2 VA (Ri=5 mΩ)
Overload for 1 s	60 A (sinusoidal)
Resolution	0.1 mA (display 0.01 A)
Sampling frequency	8.13 kHz
Fourier analysis	1st-40th harmonic

<b>Serial interface</b>	
RS-485 - Modbus RTU/Slave	9.6 kbps, 19.2 kbps, 38.4 kbps, 57.6 kbps, 115.2 kbps

<b>Digital outputs</b>	
3 digital outputs, solid state relays, not short-circuit proof.	
Switching voltage	max. 33 V AC, 40 V DC
Switching current	max. 50 mAeff AC/DC
Response time	approx. 200 ms
Pulse output	max. 50 Hz (energy pulses)

Digital output 1 (terminal 21/22) of the **UMG 96-PA MID+** provides the active energy (applied/delivered) measured value!

<b>Digital inputs</b>	
3 digital inputs, solid state relays, not short-circuit proof.	
Maximum counter frequency	20 Hz
Input signal applied	18 V ... 28 V DC (typically 4 mA)
Input signal not applied	0 .. 5 V DC, current less than 0.5 mA

<b>Cable length (digital inputs/outputs)</b>	
Up to 30 m (32.81 yd)	Unshielded
Greater than 30 m (32.81 yd)	Shielded

Analog outputs	
External power supply	max. 33 V
Current	0 .. 20 mA
Update time	1 s
Load	max. 300 $\Omega$
Resolution	10 bit

Connecting capacity of the terminals (supply voltage)	
Connectible conductors. Only connect one conductor per terminal point!	
Single core, multi-core, fine-stranded	0.2 - 4.0 mm <sup>2</sup> , AWG 28-12
Wire ferrules (non-insulated)	0.2 - 2.5 mm <sup>2</sup> , AWG 26-14
Wire ferrules (insulated)	0.2 - 2.5 mm <sup>2</sup> , AWG 26-14
Tightening torque	0.4 - 0.5 Nm (3.54 - 4.43 lbf in)
Strip length	7 mm (0.2756 in)

Connecting capacity of the terminals (voltage measurement)	
Connectible conductors. Only connect one conductor per terminal point!	
Single core, multi-core, fine-stranded	0.2 - 4.0 mm <sup>2</sup> , AWG 28-12
Wire ferrules (non-insulated)	0.2 - 2.5 mm <sup>2</sup> , AWG 26-14
Wire ferrules (insulated)	0.2 - 2.5 mm <sup>2</sup> , AWG 26-14
Tightening torque	0.4 - 0.5 Nm (3.54 - 4.43 lbf in)
Strip length	7 mm (0.2756 in)

Connecting capacity of the terminals (current measurement)	
Connectible conductors. Only connect one conductor per terminal point!	
Single core, multi-core, fine-stranded	0.2 - 4 mm <sup>2</sup> , AWG 28-12
Wire ferrules (non-insulated)	0.2 - 4 mm <sup>2</sup> , AWG 26-12
Wire ferrules (insulated)	0.2 - 2.5 mm <sup>2</sup> , AWG 26-14
Tightening torque	0.4 - 0.5 Nm (3.54 - 4.43 lbf in)
Strip length	7 mm (0.2756 in)

Terminal connection capacity (serial interface)	
Connectible conductors. Only connect one conductor per terminal point!	
Single core, multi-core, fine-stranded	0.2 - 1.5 mm <sup>2</sup> , AWG 28-16
Wire ferrules (non-insulated)	0.2 - 1.5 mm <sup>2</sup> , AWG 26-16
Wire ferrules (insulated)	0.2 - 1.5 mm <sup>2</sup> , AWG 26-16
Tightening torque	0.2 - 0.25 Nm (1.77 - 2.21 lbf in)
Strip length	7 mm (0.2756 in)

Connecting capacity of the terminals (digital inputs/outputs, analog output)	
Connectible conductors. Only connect one conductor per terminal point!	
Single core, multi-core, fine-stranded	0.2 - 1.5 mm <sup>2</sup> , AWG 28-16
Wire ferrules (non-insulated)	0.2 - 1.5 mm <sup>2</sup> , AWG 26-16
Wire ferrules (insulated)	0.2 - 1.5 mm <sup>2</sup> , AWG 26-16
Tightening torque	0.2 - 0.25 Nm (1.77 - 2.21 lbf in)
Strip length	7 mm (0.2756 in)

Firmware	
Firmware update	Please observe the operating instructions

Comment: For detailed technical information please refer to the operation manual and the Modbus address list.

Technical data for the MID+ certified measurement device	
Voltage measurement Three-phase 4-conductor systems with rated voltages up to	3 x 57.7/100 V ... 3 x 289/500 V <sup>1)</sup>
Current measurement (metering range)	0.002 ... 6 A
Frequency range	45–65 Hz
Reference frequency	50 Hz
Accuracy class	B
Pulse value S0 (pulse constant)	10.000 Impulse/kWh <sup>2)</sup>
Electromagnetic environments	Class E2 (MID 2014/32/EU)
Mechanical environments	Class M1 (MID 2014/32/EU)
Suitable grid systems	1p2w, 3p3w, 3p4w

- 1) When measuring voltage using a voltage transformer, the following applies to the UMG 96-PA-MID+:  
Use calibrated voltage transformers for a MID-compliant measurement (secondary: 3 x 57.7 / 100 V - 3 x 289/500 V).
- 2) The pulse value S0 is automatically adjusted to the set voltage transformer ratio.  
The current pulse value S0 appears in the active energy measured value display.



Fig.:UMG 96-PA basic device without module

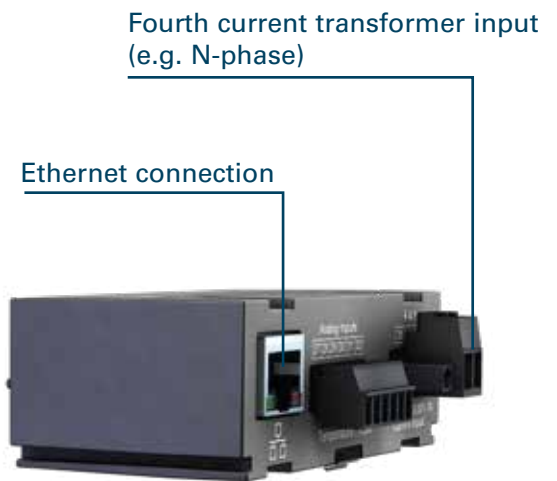
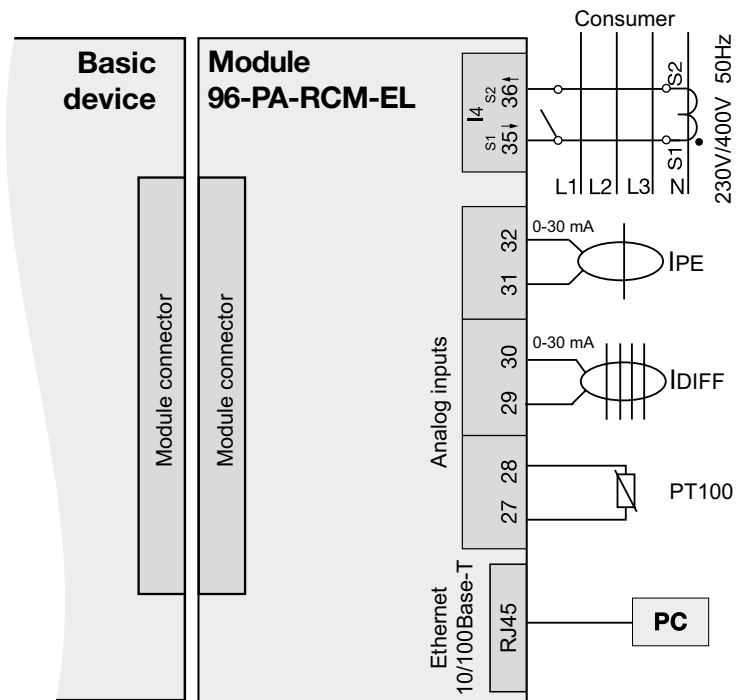


Fig.:UMG 96-PA with Ethernet connection



## Typical connection variant



Both modules can be used in conjunction with the UMG 96-PA, item no. 52.32.001 and 52.32.002



## Device overview and technical data modules



<b>Modules for the UMG 96-PA</b>	
<b>Module 96-PA-RCM-EL with Ethernet connection</b>	<b>52.32.010</b>

General	
Net weight of <b>module</b> (with attached plug-in connectors)	78 g (0.17 lbs)
Impact resistance	IK07 according to IEC 62262

Transport and storage	
The following specifications apply for devices transported and stored in the original packaging.	
Free fall	1 m (39.37 in)
Temperature	K55 -25° C (-13 °F) to +70° C (158 °F)
Relative air humidity (non-condensing)	0 to 90% RH

Environmental conditions during operation, see the usage information for your basic device.

Analog inputs	
Differential or current signals	2x
Temperature measurement	1x

Residual current input	
Nominal current	30 mA <sub>rms</sub>   0...20 mA   4...20 mA
Measurement range	0 .. 30 mA <sub>rms</sub>
Operating current	50 µA
Resolution	1 µA
Cable break detection (failure monitoring)	Can be activated
Crest factor	1.414 (relative to 30 mA)
Load	4 Ω
Overload for 1 s	1 A
Constant overloaded	200 mA
Measurement of residual currents	According to IEC/TR 60755 (2008-01):  <div style="display: flex; justify-content: space-around; align-items: center;"> <div>Type A</div>  </div> <div style="display: flex; justify-content: space-around; align-items: center;"> <div>Type B and B+</div>  </div>

Temperature measurement	
Update time	200 ms
Suitable thermal sensor	PT100, PT1000, KTY83, KTY84
Total burden (thermal sensor and lead)	max. 4 kΩ

Thermal sensor type	Temperature range	Resistance range	Measurement uncertainty
PT100	-99 °C (-146.2 °F) ... +500 °C (932 °F)	60 Ω ... 180 Ω	±1.5% rng
PT1000	-99 °C (-146.2 °F) ... +500 °C (932 °F)	600 Ω ... 1.8 kΩ	±1.5% rng
KTY83	-55 °C (-67 °F) ... +175 °C (347 °F)	500 Ω ... 2.6 kΩ	±1.5% rng
KTY84	-40 °C (-40 °F) ... +300 °C (572 °F)	350 Ω ... 2.6 kΩ	±1.5% rng



Current measurement I4	
Nominal current	5 A
Measurement range	0.005 .. 6 A <sub>RMS</sub>
Crest factor	2 (relative to 6 A <sub>RMS</sub> )
Overvoltage category	300 V CAT II
Power consumption	approx. 0.2 VA (Ri = 5 mΩ)
Sampling frequency	8.33 kHz
Resolution	16 bit
Rated surge voltage	2.5 kV
Overload for 1 s	60 A (sinusoidal)

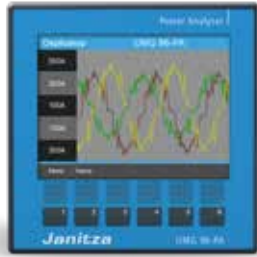
Ethernet interface (only module 96-PA-RCM-EL)		
Connection	RJ45	
Functions	Modbus gateway	
Protocols	ARP, IPv4, ICMP (ping)	
	TCP, UDP	Port: Application specific
	ModbusTCP	Port: 502
	Modbus UDP	Port: 502
	DHCP/BootP	Port: 67/68 (UDP)
	DNS server	Port: 53 (UDP)
	NTP server	Port: 123 (UDP)

Terminal connection capacity – Analog inputs (residual current, current signals, temperature)	
Connectible conductors Connect one conductor per terminal position!	
Single core, multi-core, fine-stranded	0.2 - 1.5 mm <sup>2</sup> , AWG 28-16
Wire ferrules (non-insulated)	0.2 - 1.5 mm <sup>2</sup> , AWG 26-16
Wire ferrules (insulated)	0.2 - 1.5 mm <sup>2</sup> , AWG 26-16
Tightening torque	0.2 - 0.25 Nm (1.77 - 2.21 lbf in)
Strip length	7 mm (0.2756 in)

Terminal connection capacity (current measurement I4)	
Connectible conductors Connect one conductor per terminal position!	
Single core, multi-core, fine-stranded	0.2 - 4 mm <sup>2</sup> , AWG 28-12
Wire ferrules (non-insulated)	0.2 - 4 mm <sup>2</sup> , AWG 26-12
Wire ferrules (insulated)	0.2 - 2.5 mm <sup>2</sup> , AWG 26-14
Tightening torque	0.4 - 0.5 Nm (3.54 - 4.43 lbf in)
Strip length	7 mm (0.2756 in)

Cable lengths for analog input, residual current input, temperature measurement input, current measurement input I4	
Up to 30 m (32.81 yd)	Unshielded
Greater than 30 m (32.81 yd)	Shielded

Potential isolation and electrical safety of the temperature measurement input
<p>The temperature measurement input has:</p> <ul style="list-style-type: none"> <li>· Double insulation relative to the current measurement inputs, voltage measurement inputs and the supply voltage.</li> <li>· No insulation relative to the residual current input (RCM).</li> <li>· A functional isolation relative to the Ethernet interface.</li> </ul> <p>The external temperature sensor must have double insulation relative to hazardous contact voltage (according to IEC 61010-1:2010).</p>



**UMG 96-PA**

**Item no. 52.32.001 (90 ... 277 V AC/90 ... 250 V DC)**

**Item no. 52.32.002 (24 ... 90 V AC/DC)**

- Modular design with Modbus gateway (TCP/IP) and optional Ethernet module
- Comprehensive functions and versatile range of applications
- Active energy class 0.2S



**UMG 96-PA-MID+**

**Item no. 52.32.004 (90 ... 277 V AC/90 ... 250 V DC)**

- MID certification to Directive 2014/32/EU
- Tamper-proof installation possible
- Serial meter readings as per PTB-A 50.7 with separate measuring data storage for 2 years



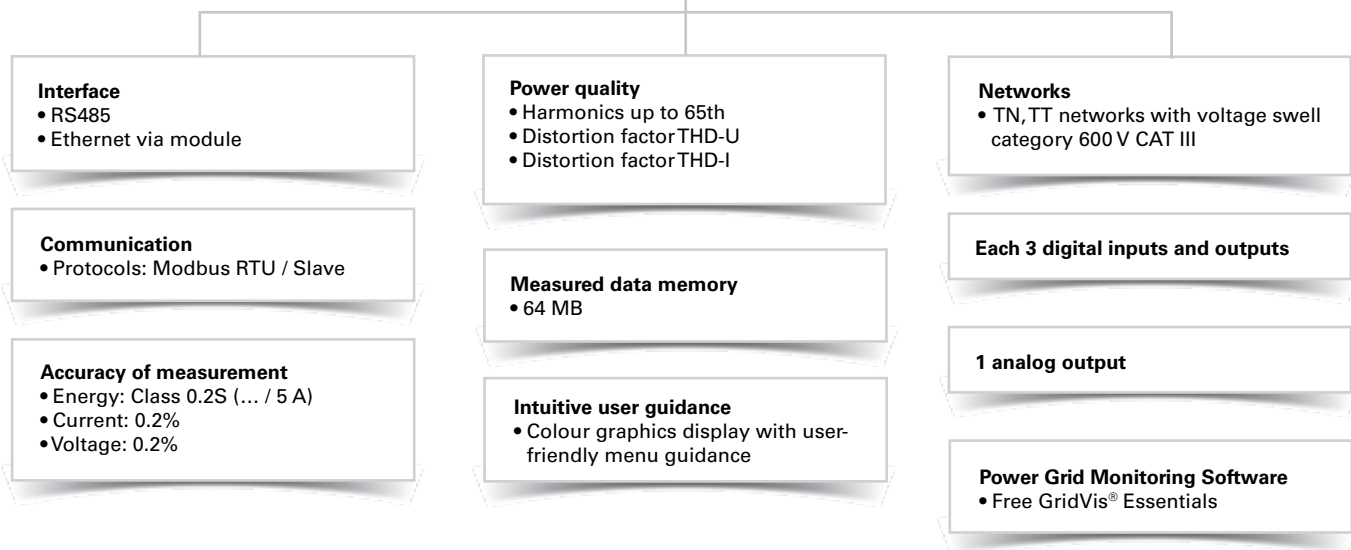
**Module UMG 96-PA-RCM-EL**

**Item no. 52.32.010**

- Ethernet interface
- 2 residual current inputs
- Temperature measurement
- 4th current input

# UMG 96-PQ-L

Modularly expandable power analyzer



## Areas of application



- Energy supplier
- General industry
- Computing centers

## Main features



### Power quality

- Harmonics current up to the 65th harmonic
- Sampling frequency 13.67 kHz



### Functional expansion through additional modules

- Temperature measurement with monitoring via integrated comparator
- Optionally with Ethernet interface and Modbus gateway
- Residual current measurement or DC power measurement
- Neutral conductor measurement (I4 – current measurement)

### Performance characteristics

- 3 voltage measurement inputs (600 V CAT III)
- 3 current measurement input
- Continuous sampling of the voltage and current measurement inputs
- Measurement of reactive distortion power
- Transmission of the measured values via a serial interface
- Class 0.2S
- High memory depth with low memory requirements



Fig.: UMG 96-PQ-L  
modularly expandable power analyzer



Fig.: UMG 96-PQ-L module with Ethernet connection

### Digitale IOs

- Additional application possibilities afforded with extensive peripherals (three digital inputs and outputs as well as one analog output)
- Extensive IO configuration options for intelligent integration for the monitoring of limit values & notification of exceedances



### User-friendly, color graphic display with intuitive user guidance

- High-resolution color graphic display, 320 x 240 pixels, 6 buttons
- User-friendly, self-explanatory and intuitive operation
- Display of measured values in numerical form, as a bar graph or line graph

### Visualization

- Oscilloscope function
- Phasor diagram on the display

### Drag indicator history on the display

- Detect overloads in the system / station at a glance
- Averaging interval is configurable
- Fixed time basis
- Synchronization via Modbus
- Resettable on display
- The three highest values per measured value and phase

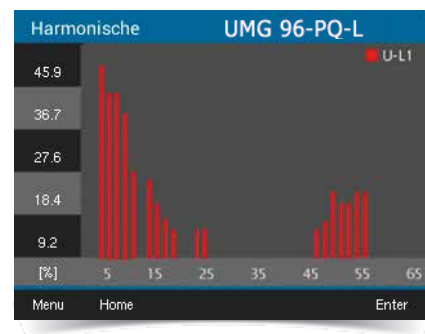


Fig.: Measuring display for harmonics (e.g. Voltage L1)

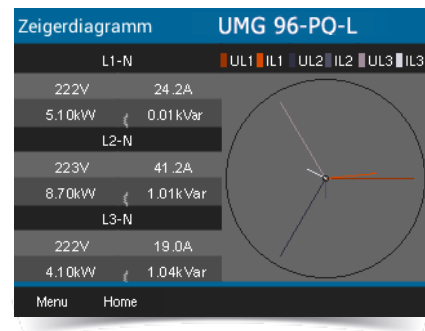
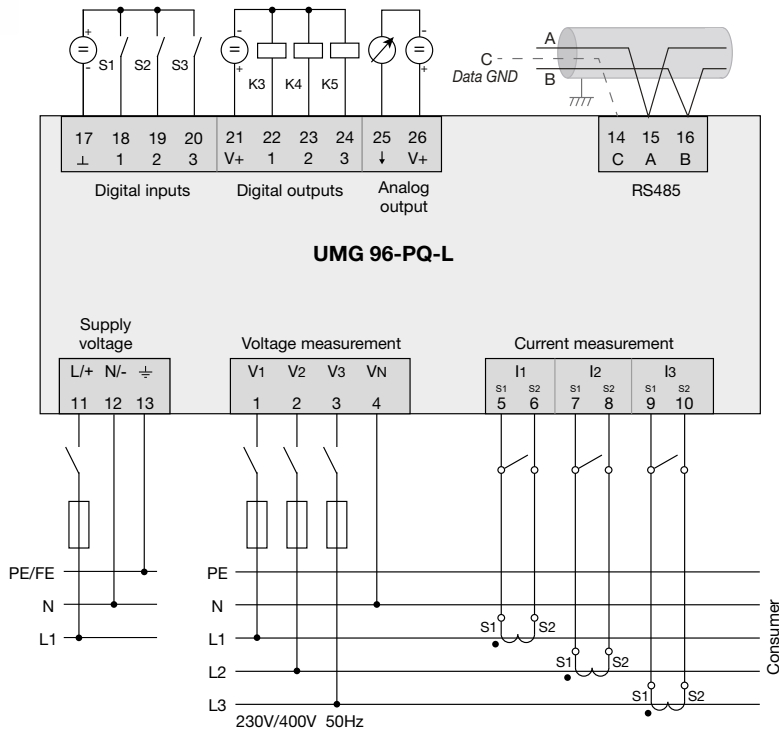


Fig.: Phasor diagram



## Typical connection variant

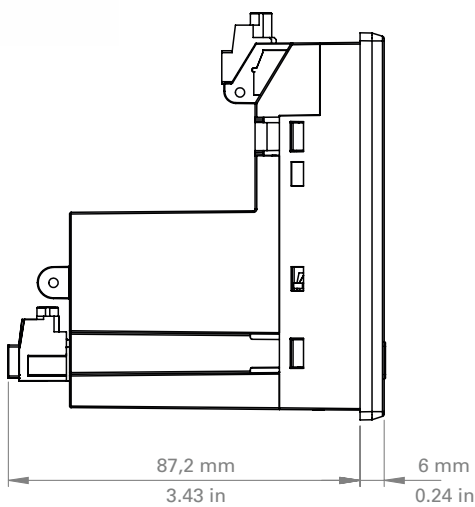


- 1) UL/IEC approved overcurrent protective device
- 2) UL/IEC approved overcurrent protective device
- 3) Short circuit bridges (external)

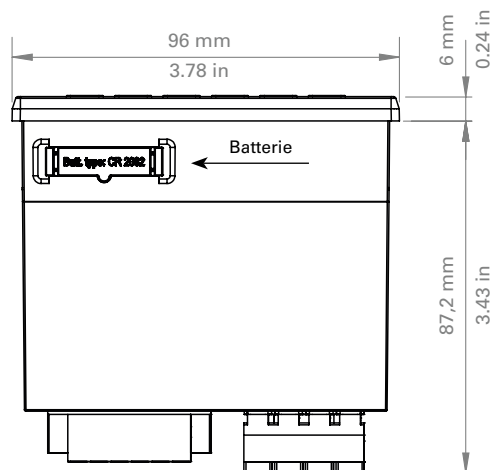


## Dimension diagrams

All dimensions in mm



Side view



Bottom view

**Cutout dimensions:**  
92<sup>+0,8</sup> x 92<sup>+0,8</sup> mm



## Device overview and technical data, basic device

UMG 96-PQ-L	
Item number (90–277 V AC / 90–250 V DC)	52.36.001
Item number (24–90 V AC / 24–90 V DC)	52.36.002

General	
Net weight (with attached plug-in connectors)	Approx. 250 g (0.55 lbs)
Package weight (incl. accessories)	Approx. 500 g (1.1 lbs)
Battery	Type Lithium CR2032, 3 V, (UL 1642 approved)
Data memory	64 MB
Backlight service life	40000 h (backlight reduces to approx. 50% over this period)
Impact resistance	IK07 according to IEC 62262

Transport and storage	
The following information applies to devices that are transported or stored in their original packaging.	
Free fall	1 m (39.37 in)
Temperature	-25 °C (-13 °F) to +70 °C (158 °F)
Relative air humidity (non-condensing)	0 to 90% RH

Environmental conditions during operation	
Install the device in a weather-protected and stationary location. Protection class II according to IEC 60536 (VDE 0106, Part 1).	
Rated temperature range	-10 °C (14 °F) ... +55 °C (131 °F)
Relative air humidity (non-condensing)	0 to 75% RH
Operating elevation	0 .. 2000 m (6562 ft) above sea level
Pollution degree	2
Mounting orientation	As desired
Ventilation	No forced ventilation required.
Protection against foreign matter and water	
- Front	IP40 according to EN60529
- Rear	IP20 according to EN60529
- Front with seal	IP54 according to EN60529

Supply voltage		
Option 230 V	Nominal range	AC 90 V - 277 V (50/60 Hz) or DC 90 V - 250 V, 300 V CAT III
	Power consumption	Max. 4.5 VA / 2 W
Option 24 V	Nominal range	AC 24 V - 90 V (50/60Hz) or DC 24 V - 90 V, 150 V CAT III
	Power consumption	Max. 4.5 VA / 2 W
Operating range	+/-10% of nominal range	
Internal fuse, not replaceable	Type T1A / 250 V DC / 277 V AC according to IEC 60127	
Recommended overcurrent protective device for the line protection (UL approval)	Option 230 V: 6 - 16 A (Char. B) Option 24 V: 1 - 6 A (Char. B)	

Recommendation for the maximum number of devices on a line circuit breaker:  
 Option 230 V: Line circuit breaker B6A: max. 4 devices / line circuit breaker B16A: max. 11 devices  
 Option 24 V: Line circuit breaker B6A: max. 3 devices / line circuit breaker B16A: max. 9 devices

<b>Voltage measurement</b>	
Three-phase 4-conductor systems with rated voltages up to	417 V / 720 V (+-10%) according to IEC 347 V / 600 V (+-10%) according to UL
Three-phase 3-conductor system with rated voltages up to	600 V (+-10%)
Single-phase 2-conductor system with rated voltages up to	480 V (+-10%)
Overvoltage category	600 V CAT III
Rated surge voltage	6 kV
Protection of the voltage measurement	1 - 10 A (with IEC/UL approval)
Measuring range L-N	0 <sup>1)</sup> ... 600 Vrms (max. overvoltage 800 Vrms)
Measuring range L-L	0 <sup>1)</sup> ... 1040 Vrms (max. overvoltage 1350 Vrms)
Resolution	0.01 V
Crest factor	2.45 (related to the measuring range)
Impedance	3 MΩ/phase
Power consumption	Approx. 0.1 VA
Sampling frequency	13.67 kHz
Frequency of the fundamental oscillation	45 Hz .. 65 Hz
- Resolution	0.01 Hz
Fourier analysis	1st - 65th harmonic

1) The device only determines measured values if a voltage L1-N of greater than 20 Veff (4-conductor measurement) or a voltage L1-L2 of greater than 34 Veff (3-conductor measurement) is applied to voltage measurement input V1.

<b>Current measurement</b>	
Nominal current	5 A
Measurement range	0.005 .. 6 Arms
Crest factor	2 (relative to 6 Arms)
Overvoltage category	300 V CAT II
Rated surge voltage	2 kV
Power consumption	Approx. 0.2 VA (Ri=5 mΩ)
Overload for 1 s	60 A (sinusoidal)
Resolution	0.1 mA (display 0.01 A)
Sampling frequency	13.67 kHz
Fourier analysis	1st - 65th harmonic

<b>Serial interface</b>	
RS-485 - Modbus RTU/Slave	9.6 kbps, 19.2 kbps, 38.4 kbps, 57.6 kbps, 115.2 kbps

<b>Digital outputs</b>	
3 digital outputs, solid state relays, not short-circuit proof.	
Switching voltage	Max. 33 V AC, 40 V DC
Switching current	Max. 50 mAeff AC/DC
Response time	Approx. 200 ms
Pulse output	Max. 50 Hz (energy pulses)

<b>Digital inputs</b>	
3 digital inputs, solid state relays, not short-circuit proof.	
Maximum counter frequency	20 Hz
Input signal applied	18 V .. 28 V DC (typically 4 mA)
Input signal not applied	0 .. 5 V DC, current less than 0.5 mA

<b>Cable length (digital inputs/outputs)</b>	
Up to 30 m (32.81 yd)	Unshielded
Greater than 30 m (32.81 yd)	Shielded



<b>Analog outputs</b>	
External power supply	Max. 33 V
Current	0 .. 20 mA
Update time	1 s
Load	Max. 300 $\Omega$
Resolution	10 bit

<b>Connecting capacity of the terminals (supply voltage)</b>	
Connectible conductors. Only connect one conductor per terminal point!	
Single core, multi-core, fine-stranded	0.2 - 4.0 mm <sup>2</sup> , AWG 28-12
Wire ferrules (non-insulated)	0.2 - 2.5 mm <sup>2</sup> , AWG 26-14
Wire ferrules (insulated)	0.2 - 2.5 mm <sup>2</sup> , AWG 26-14
Tightening torque	0.4 - 0.5 Nm (3.54 - 4.43 lbf in)
Strip length	7 mm (0.2756 in)

<b>Connecting capacity of the terminals (voltage measurement)</b>	
Connectible conductors. Only connect one conductor per terminal point!	
Single core, multi-core, fine-stranded	0.2 - 4.0 mm <sup>2</sup> , AWG 28-12
Wire ferrules (non-insulated)	0.2 - 2.5 mm <sup>2</sup> , AWG 26-14
Wire ferrules (insulated)	0.2 - 2.5 mm <sup>2</sup> , AWG 26-14
Tightening torque	0.4 - 0.5 Nm (3.54 - 4.43 lbf in)
Strip length	7 mm (0.2756 in)

<b>Connecting capacity of the terminals (current measurement)</b>	
Connectible conductors. Only connect one conductor per terminal point!	
Single core, multi-core, fine-stranded	0.2 - 4 mm <sup>2</sup> , AWG 28-12
Wire ferrules (non-insulated)	0.2 - 4 mm <sup>2</sup> , AWG 26-12
Wire ferrules (insulated)	0.2 - 2.5 mm <sup>2</sup> , AWG 26-14
Tightening torque	0.4 - 0.5 Nm (3.54 - 4.43 lbf in)
Strip length	7 mm (0.2756 in)

<b>Terminal connection capacity (serial interface)</b>	
Connectible conductors. Only connect one conductor per terminal point!	
Single core, multi-core, fine-stranded	0.2 - 1.5 mm <sup>2</sup> , AWG 28-16
Wire ferrules (non-insulated)	0.2 - 1.5 mm <sup>2</sup> , AWG 26-16
Wire ferrules (insulated)	0.2 - 1.5 mm <sup>2</sup> , AWG 26-16
Tightening torque	0.2 - 0.25 Nm (1.77 - 2.21 lbf in)
Strip length	7 mm (0.2756 in)

<b>Connecting capacity of the terminals (digital inputs/outputs, analog output)</b>	
Connectible conductors. Only connect one conductor per terminal point!	
Single core, multi-core, fine-stranded	0.2 - 1.5 mm <sup>2</sup> , AWG 28-16
Wire ferrules (non-insulated)	0.2 - 1.5 mm <sup>2</sup> , AWG 26-16
Wire ferrules (insulated)	0.2 - 1.5 mm <sup>2</sup> , AWG 26-16
Tightening torque	0.2 - 0.25 Nm (1.77 - 2.21 lbf in)
Strip length	7 mm (0.2756 in)

<b>Firmware</b>	
Firmware update	Please observe the operating instructions

Remark: For detailed technical information, please refer to the operation manual and Modbus address list.



## Device overview and technical data modules



<b>Module for the UMG 96-PQ-L</b>	
<b>Module 96-PA-RCM-EL with Ethernet connection</b>	<b>52.32.010</b>

General	
Net weight of <b>module</b> (with attached plug-in connectors)	78 g (0.17 lbs)
Impact resistance	IK07 according to IEC 62262

Transport and storage	
The following specifications apply for devices transported and stored in the original packaging.	
Free fall	1 m (39.37 in)
Temperature	K55 -25° C (-13 °F) to +70° C (158 °F)
Relative air humidity (non-condensing)	0 to 90% RH

Environmental conditions during operation, see the usage information for your basic device.

Analog inputs	
Differential or current signals	2x
Temperature measurement	1x

Residual current input	
Nominal current	30 mA <sub>rms</sub>   0...20 mA   4...20 mA
Measurement range	0 .. 30 mA <sub>rms</sub>
Operating current	50 µA
Resolution	1 µA
Cable break detection (failure monitoring)	Can be activated
Crest factor	1.414 (relative to 30 mA)
Load	4 Ω
Overload for 1 s	1 A
Constant overloaded	200 mA
Measurement of residual currents	According to IEC/TR 60755 (2008-01):  Type A  Type B and B+ 

Temperature measurement	
Update time	200 ms
Suitable thermal sensor	PT100, PT1000, KTY83, KTY84
Total burden (thermal sensor and lead)	max. 4 kΩ

Thermal sensor type	Temperature range	Resistance range	Measurement uncertainty
PT100	-99 °C (-146.2 °F) ... +500 °C (932 °F)	60 Ω ... 180 Ω	±1.5% rng
PT1000	-99 °C (-146.2 °F) ... +500 °C (932 °F)	600 Ω ... 1.8 kΩ	±1.5% rng
KTY83	-55 °C (-67 °F) ... +175 °C (347 °F)	500 Ω ... 2.6 kΩ	±1.5% rng
KTY84	-40 °C (-40 °F) ... +300 °C (572 °F)	350 Ω ... 2.6 kΩ	±1.5% rng

# UMG 509-PRO

Multifunctional power quality analyzer

Power quality



Ethernet connection



Graphic programming



Residual current monitoring



Ethernet-Modbus gateway



Alarm management

## Communication

- Profibus (DP/V0)
- Modbus (RTU, TCP, Gateway)
- TCP/IP
- BACnet (optional)
- HTTP (Homepage)
- FTP (File transfer)
- SNMP
- TFTP
- NTP (time synchronisation)
- SMTP (email function)
- DHCP

## Interfaces

- Ethernet
- Profibus (DSUB-9)
- RS485 Modbus (terminal strip)

## Accuracy of measurement

- Energy: Class 0.2S (... / 5 A)
- Current: 0.2 %
- Voltage: 0.1 %

## Power quality

- Harmonics up to 63th harmonic
- Short-term interruptions (> 20 ms)
- Transient recorder (> 50 µs)
- Starting currents (> 20 ms)
- Unbalance

## Networks

- IT, TN, TT networks
- 3 and 4-phase networks
- Up to 4 single-phase networks

## Measured data memory

- 256 MByte Flash
- 32 MB SDRAM

## PLC functionality

- Graphical programming
- Jasic® programming language
- Programming of threshold values etc.

## 2 digital inputs

- Pulse input
- Logic input
- State monitoring
- HT / LT switching

## 2 digital outputs

- Pulse output kWh / kvarh
- Switch output
- Threshold value output
- Logic output

## Power Grid Monitoring Software

- Free GridVis® Essentials

## Thermistor input

- PT100, PT1000, KTY83, KTY84

## RCM – Residual Current Monitoring

- 2 residual current inputs



## Areas of application



- Continuous monitoring of the power quality
- Energy management systems (ISO 50001)
- Master device with Ethernet gateway for subordinate measurement points
- Visualisation of the energy supply in the LVDB
- Analysis of electrical disturbances in the event of power quality problems
- Cost centre analysis
- Remote monitoring in the property operation
- Use in test fields (e.g. in universities)

## Main features

### High quality measurement with high sampling rate (20 kHz per channel)



#### Power quality

- Harmonics analysis up to 63rd harmonic
- Acquisition of short-term interruptions
- Acquisition of transients
- Display of waveforms (current and voltage)
- Unbalance
- Vector diagram

### RCM (Residual Current Monitoring)



- Continuous monitoring of residual currents (Residual Current Monitor, RCM)
- Alarming in case a preset threshold fault current reached
- Near-realtime reactions for triggering countermeasures
- Permanent RCM measurement for systems in permanent operation without the opportunity to switch off
- Ideal for the central earthing point in TN-S systems

### Modern communications architecture via Ethernet



- Ethernet interface and web server
- Faster, better cost-optimised and more reliable communication system
- High flexibility due to the use of open standards
- Integration in PLC systems and BMS through additional interfaces
- BACnet optionally available
- Up to 4 ports simultaneous
- Versatile IP protocols

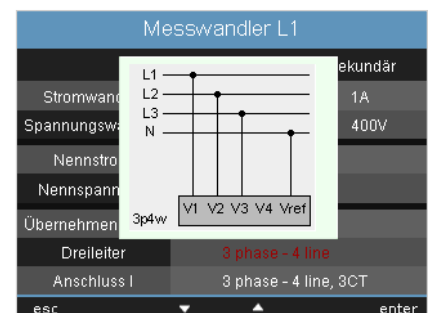


Fig.: Example for the configuration of current measurement via 3 current transformers in a three-phase 4-wire network on the UMG 509-PRO display

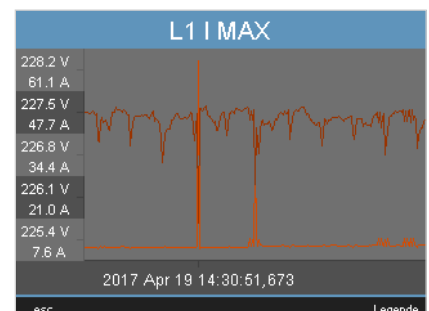


Fig.: Illustration of the full wave effective values for an event (voltage drop)



### Modbus Gateway function

- Economical connection of devices without Ethernet interface
- Integration of devices with Modbus-RTU interface possible
- Data can be scaled and described
- Minimised number of IP addresses required



### Graphical programming

- Comprehensive programming options (PLC functionality)
- Jasic® source code programming
- Sustainable functional expansions far beyond pure measurement
- Complete APPs from the Janitza library



### Powerful alarm management\*

- Can be programmed via the graphic programming or Jasic® source code
- All measured values can be used
- Can be arbitrarily, mathematically processed
- Individual forwarding via email sending, switching of digital outputs, writing to Modbus addresses etc.
- Watchdog APPs

\*The range of functions depends on the selected GridVis® edition. An overview of the activated functions per edition can be found on:  
<https://www.gridvis.com/gridvis-editions.html>

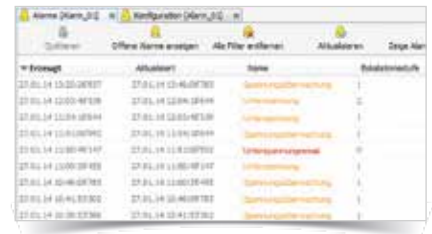


Fig.: GridVis® – Alarmmanagement

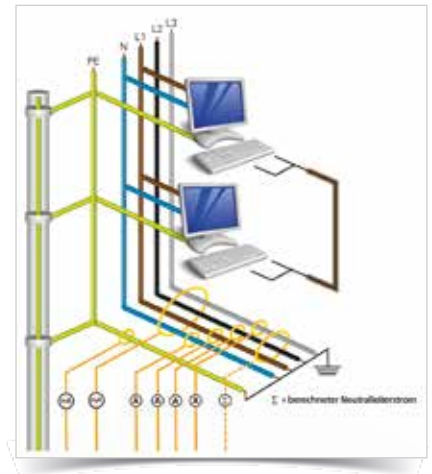


Fig.: Example RCM measurement

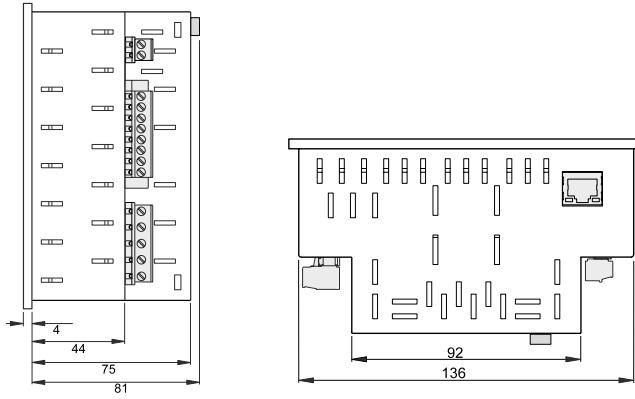


↑  
Ethernet connection



## Dimension diagrams

All dimensions in mm



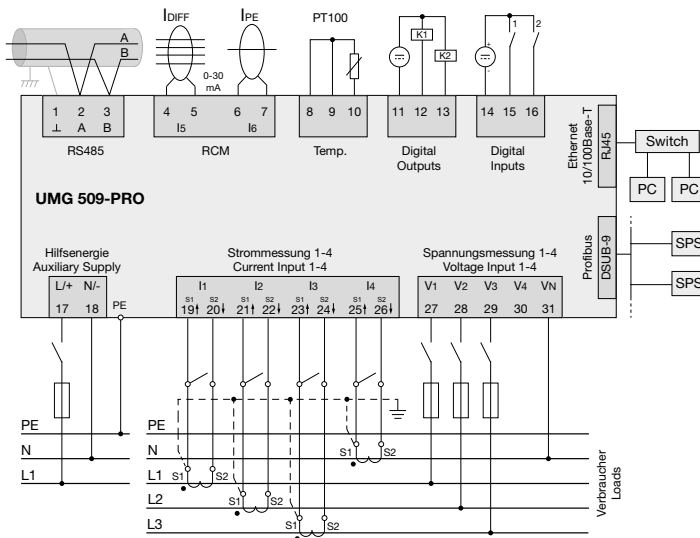
Side view

View from below

Cut out:  $138^{+0,8} \times 138^{+0,8}$  mm



## Typical connection





## Device overview and technical data

Item number	UMG 509-PRO	
	52.26.001	52.26.003
AC supply voltage	95 to 240 V AC	48 to 110 V AC
Supply voltage DC	80 to 300 V DC	24 to 150 V DC
<b>Device options</b>		
BACnet communication	<b>52.26.081</b>	<b>52.26.081</b>

General	
Net weight (with attached connectors)	approx. 1080 g (2.38 lb)
Device dimensions (W x H x D)	approx. 144 x 75 x 144 mm (5.67 x 2.95 x 5.67 in)
Battery	type Li-Mn CR2450, 3V (approval i.a.w. UL 1642)
Clock (in temperature range -40 °C to 85 °C)	+5 ppm (corresponding to approx. 3 minutes per year)

Transport and storage	
The following information applies to devices which are transported or stored in the original packaging.	
Free fall	1 m (39.37 in)
Temperature	-25 °C to +70 °C (-13 °F ..to 158 °F)

Ambient conditions during operation	
The device is intended for weather-protected, stationary use. The device must be connected to the ground wire connection! Protection class I in acc. with IEC 60536 (VDE 0106, Part 1).	
Working temperature range	-10 °C .. +55 °C (14 °F ..to 131 °F)
Relative humidity	5 to 95% (at 25 °C/77 °F) without condensation
Operating altitude	0 to 2000 m above sea level
Pollution degree	2
Installation position	upright
Ventilation	forced ventilation is not required.
Protection against ingress of solid foreign bodies and water	IP40 in acc. with EN60529 IP20 in acc. with EN60529

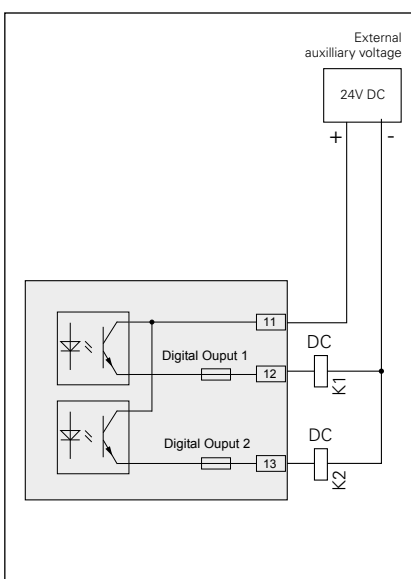


Fig. Example for two electronical relays connected to the digital outputs

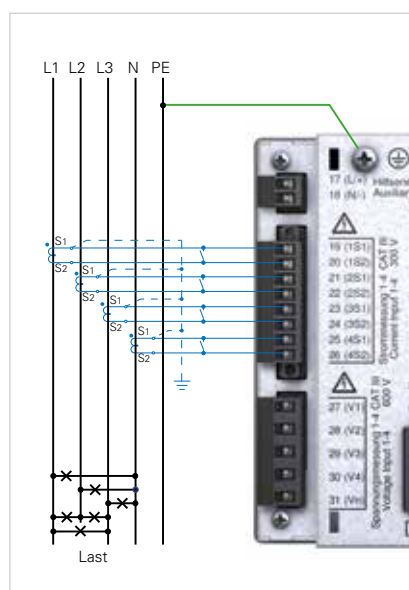


Fig.: Example current measurement

<b>Supply voltage</b>	
Installations of overvoltage category	300 V CAT III
Protection of the supply voltage (fuse)	6 A, type B (approved as per UL/IEC)
230 V option: - Nominal range - Operating range - Power consumption	95 V to 240 V (50/60 Hz) / DC 80 V to 300 V ± 10% of nominal range max. 7 W / 14 VA
24V option: • Nominal range • Operating range • Power consumption	48 V to 110 V (50/60 Hz) or DC 24 to 150 V ± 10% of nominal range max. 9 W / 13 VA

<b>Terminal connection capacity (supply voltage)</b>	
Connectable conductors. Only one conductor can be connected per terminal!	
Single core, multi-core, fine-stranded	0.2 – 2.5 mm <sup>2</sup> , AWG 24 - 12
Terminal pins, core end sheath	0.25 – 2.5 mm <sup>2</sup>
Tightening torque	0.5 – 0.6 Nm
Stripping length	7 mm (0.2756 in)

<b>Current measurement</b>	
Rated current	5 A
Resolution	0.1 mA
Metering range	0.005 to 7 A <sub>rms</sub>
Measurement range exceeded (overload)	from 7.5 A <sub>rms</sub>
Crest factor	2.4
Overvoltage category	230 V option: 300 V CAT III 24 V option: 300 V CAT II
Measurement voltage surge	4 kV
Power consumption	approx. 0.2 VA (Ri = 5 mOhm)
Overload for 1 sec.	120 A (sinusoidal)
Sampling rate	20 kHz / phase

<b>Voltage measurement</b>	
The voltage measurement inputs are suitable for measurements in the following power supply systems:	
Three-phase 4-conductor systems with rated voltages up to	417 V / 720 V 347 V / 600 V UL listed
Three-phase 3-conductor systems with rated voltages up to	600 V
From a safety and reliability perspective, the voltage measurement inputs are designed as follows:	
Overvoltage category	600 V CAT III
Measurement voltage surge	6 kV
Protection of voltage measurement	1 – 10 A
Metering range L-N	0 <sup>1)</sup> to 600 V <sub>rms</sub>
Metering range L-L	0 <sup>1)</sup> to 1000 V <sub>rms</sub>
Resolution	0.01 V
Crest factor	1.6 (related to 600 V <sub>rms</sub> )
Impedance	4 MOhm / phase
Power consumption	approx. 0.1 VA
Sampling rate	20 kHz / phase
Transients	> 50 µs
Frequency of the fundamental oscillation - Resolution	40 Hz to 70 Hz 0.001 Hz

1 ) The device can only determine measured values, if an L-N voltage of greater than 10 Veff or an L-L voltage of greater than 18 Veff is applied to at least one voltage measurement input.

<b>Phase angle accuracy of measurement</b>	0.075°
--	--------



<b>Terminal connection capacity (voltage and current measurement)</b>	
Connectable conductors. Only one conductor can be connected per terminal!	
Single core, multi-core, fine-stranded	0.2 – 2.5 mm <sup>2</sup> , AWG 24-12
Terminal pins, core end sheath	0.25 – 2.5 mm <sup>2</sup>
Tightening torque	0.5 – 0.6 Nm
Stripping length	7 mm (0.2756 in)

<b>Residual current monitoring (RCM)</b>	
Rated current	30 mA <sub>rms</sub>
Metering range	0 to 40 mA <sub>rms</sub>
Triggering current	100 µA
Resolution	1 µA
Crest factor	1.414 (related to 40 mA)
Burden	4 Ohm
Overload for 1 sec.	5 A
Sustained overload	1 A
Overload for 20 ms	50 A
Residual current monitoring	i.a.w. IEC/TR 60755 (2008-01), type A
Maximum external burden	300 Ohm (for cable break detection)

<b>Terminal connection capacity (residual current monitoring)</b>	
Connectable conductors. Only one conductor can be connected per terminal!	
Rigid/flexible	0.14 – 1.5 mm <sup>2</sup> , AWG 28-16
Flexible with core end sheath without plastic sleeve	0.20 – 1.5 mm <sup>2</sup>
Flexible with core end sheath with plastic sleeve	0.20 – 1.5 mm <sup>2</sup>
Stripping length	7 mm (0.2756 in)
Tightening torque	0.20 – 0.25 Nm (1.77 - 2.21 lbf in)
Cable length	up to 30 m (32.81 yd) unshielded, from 30 m (32.81 yd) shielded

<b>Temperature measurement input</b>	
3-wire measurement	
Update time	1 second
Connectable sensors	PT100, PT1000, KTY83, KTY84
Total burden (sensor + cable)	max. 4 kOhm
Cable length	up to 30 m (32.81 yd) unshielded, from 30 m (32.81 yd) shielded

Sensor type	Temperature range	Resistor range	Measurement uncertainty
KTY83	-55° C to +175° C (-67 °F ..to 347 °F)	500 Ohm to 2.6 kOhm	± 1.5% rng
KTY84	-40° C to +300° C (-40 °F ..to 572 °F)	350 Ohm to 2.6 kOhm	± 1.5% rng
PT100	-99° C to +500° C (-146.2 °F ..to 932 °F)	60 Ohm to 180 Ohm	± 1.5% rng
PT1000	-99° C to +500° C (-146.2 °F ..to 932 °F)	600 Ohm to 1.8 kOhm	± 1.5% rng

<b>Terminal connection capacity (temperature measurement input)</b>	
Connectable conductors. Only one conductor can be connected per terminal!	
Single core, multi-core, fine-stranded	0.08 – 1.5 mm <sup>2</sup>
Terminal pins, core end sheath	1 mm <sup>2</sup>

<b>Digital inputs</b>	
2 Digital inputs with a joint earth	
Maximum counter frequency	20 Hz
Response time (Jasic program)	200 ms
Input signal present	18 V to 28 V DC (typical 4 mA)
Input signal not present	0 to 5 V DC, current less than 0.5 mA
Cable length	up to 30 m (32.81 yd) unshielded, from 30 m (32.81 yd) shielded

<b>Digital outputs</b>	
2 digital outputs with a joint earth; opto coupler, not short-circuit proof	
Supply voltage	20 V - 30 V DC (SELV or PELV supply)
Switching voltage	max. 60 V DC, 30 V AC
Switching current	max. 50 mA <sub>eff</sub> AC/DC
Response time (Jasic program)	200 ms
Output of voltage dips	20 ms
Output of voltage exceedance events	20 ms
Switching frequency	max. 20 Hz
Cable length	up to 30 m (32.81 yd) unshielded, from 30 m (32.81 yd) shielded

<b>Terminal connection capacity (digital inputs and outputs)</b>	
Rigid/flexible	0.14 - 1.5 mm <sup>2</sup> , AWG 28-16
Flexible with core end sheath without plastic sleeve	0.25 - 1.5 mm <sup>2</sup>
Flexible with core end sheath with plastic sleeve	0.25 - 0.5 mm <sup>2</sup>
Tightening torque	0.22 - 0.25 Nm (1.77 - 2.21 lbf in)
Stripping length	7 mm (0.2756 in)

<b>RS485 interface</b>	
3-wire connection with GND, A, B	
Protocol	Modbus RTU/slave, Modbus RTU/master, Modbus RTU /gateway
Transmission rate	9.6 kbps, 19.2 kbps, 38.4 kbps, 57.6 kbps, 115.2 kbps, 921.6 kbps
Termination resistor	can be activated by micro switch

<b>Profibus interface</b>	
Connection	SUB D 9-pin
Protocol	Profibus DP/V0 per EN 50170
Transmission rate	9.6 kBaud to 12 MBaud

<b>Ethernet interface</b>	
Connection	RJ45
Function	Modbus gateway, embedded web server (HTTP)
Protocols	CP/IP, EMAIL (SMTP), DHCP client (BootP), Modbus/TCP, Modbus RTU over Ethernet, FTP, ICMP (Ping), NTP, TFTP, BACnet (optional), SNMP

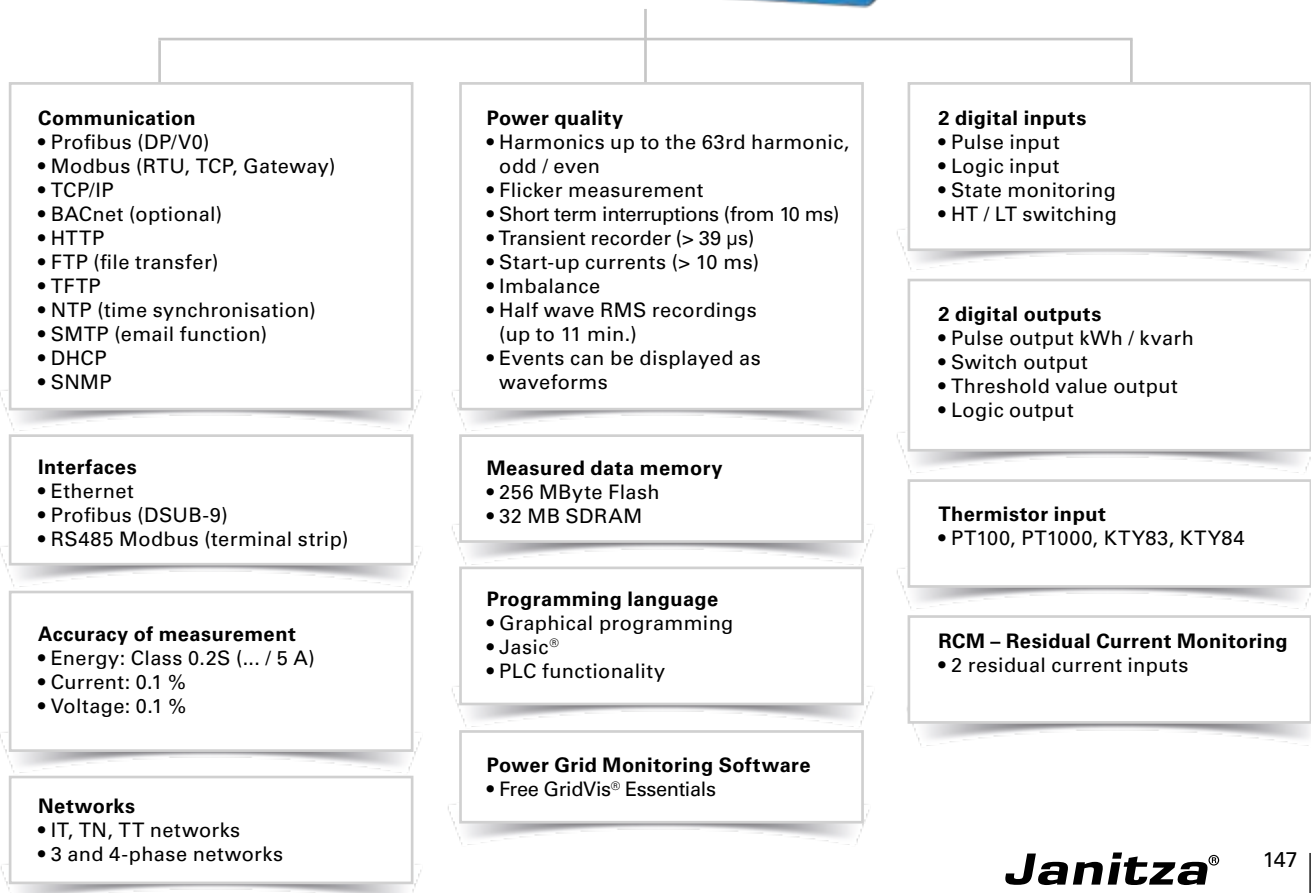
<b>Firmware</b>	
Firmware update	Please observe the operating instructions

Comment: For detailed technical information please refer to the operation manual and the Modbus address list.

**Certificated**

# UMG 512-PRO

Class A power quality analyzer





## Areas of application



- Continuous monitoring of the power quality
- Harmonics analysis with power quality problems
- Checking the internal supply network according to EN 61000-4-7, EN 61000-4-15, IEC 61000-4-30
- Fault analysis in case of problems with the energy supply
- Documentation of the power quality for customers and regulatory authorities
- Ethernet Gateway for subordinate measurement points
- Report generator for power quality standards: EN 50160, IEE519, EN61000-2-4, ITIC ...
- Report generator for energy consumptions
- Energy Dashboard
- Remote monitoring of critical processes

## Main features

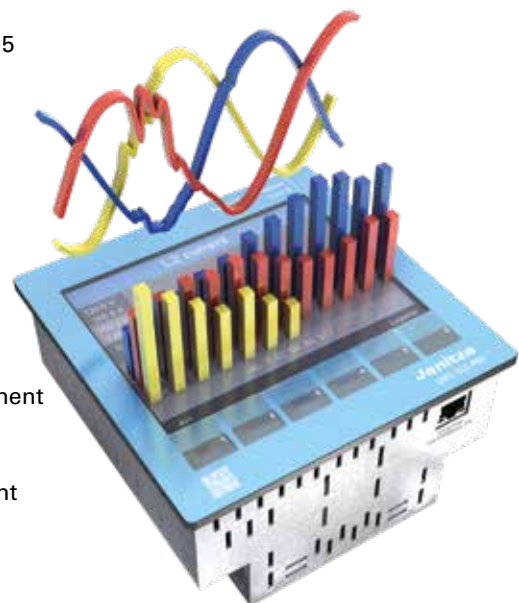


### Power quality

- Harmonics analysis up to the 63rd harmonic, even / odd (U, I, P, Q)
- Interharmonics (U, I)
- Distortion factor THD-U / THD-I / TDD
- Measurement of positive, negative and zero sequence component
- Unbalance
- Direction of rotation field
- Voltage crest factor
- Flicker measurement in accordance with DIN EN 61000-4-15
- Logging and storage of transients ( $> 39 \mu\text{s}$ )
- Short-term interruptions ( $> 10 \text{ ms}$ )
- Monitoring start-up processes

### High quality measurement

- Constant true RMS measurement
- Measurement process in accordance with IEC 61000-4-30
- Certified accuracy of measurement according to class A
- Continuous sampling of the voltage and current measurement inputs at 25,6 kHz
- 512 measurement points per period
- Recording of over 2,000 measured values per measurement cycle
- Accuracy of active energy measurement: Class 0.2S
- Fast measurement even enables the logging of rapid transients from 39  $\mu\text{s}$
- Logging of currents and voltages (15 – 440 Hz)





### RCM (Residual Current Monitoring)

- Continuous monitoring of residual currents (Residual Current Monitor, RCM)
- Alarming in case a preset threshold fault current reached
- Near-realtime reactions for triggering countermeasures
- Permanent RCM measurement for systems in permanent operation without the opportunity to switch off
- Ideal for the central earthing point in TN-S systems



### User-friendly, colour graphical display with intuitive user guidance

- High resolution colour graphical display 320 x 240, 256 colours, 6 buttons
- User-friendly, self-explanatory and intuitive operation
- Backlight for optimum reading, even in darker environments
- Illustration of measured values in numeric form, as a bar graph or line graph
- Clear and informative representation of online graphs and power quality events
- Multilingual: German, English, Russian, Spanish, Chinese, French, Turkish ...

### Various characteristics

- 4 voltage and 6 current measurement inputs
- 2 digital inputs, e.g. as data logger for S0 meter
- 2 digital outputs for alarm message or e.g. for connection to a BMS or PLC
- Free name assignment for the digital IOs, e.g. if used as data logger

### Comprehensive communication and connection possibilities

- Modbus
- Profibus
- Ethernet (TCP/IP)
- Digital IOs
- BACnet (optional)
- Configurable Firewall

Ereignisse (1..8)		
Phase	Art	Datum/Uhrzeit
L1	U MIN	2017 May 3 12:19:00,625
L1	I MAX	2017 Apr 19 14:30:51,673
L1	I MAX	2017 Apr 19 13:50:04,705
L1	I MAX	2017 Apr 19 13:49:34,695
L1	I MAX	2017 Mar 16 16:20:19,123
L3	U MIN	2017 Feb 24 02:50:38,935
L2	U MIN	2017 Jan 21 13:27:40,437
L1	I MAX	2016 Dec 4 04:22:15,115

Fig.: Event list

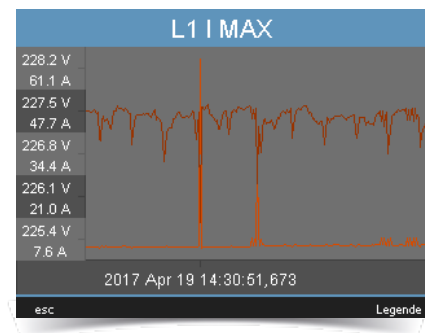


Fig.: Graphical event display (voltage drop)

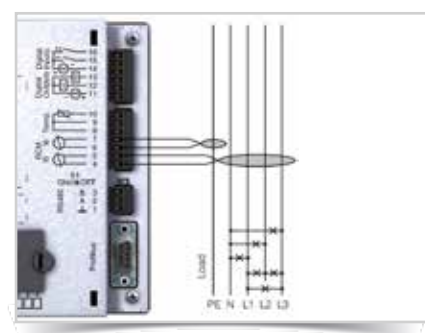


Abb.: Connection example of residual current monitoring and PE via current transformers



### Modern communications architecture via Ethernet

- Simple integration in an Ethernet network
- Reliable and cost-optimised establishment of communication
- Ideal for Master-Slave structures
- High flexibility due to the use of open standards
- Integration in PLC systems and BMS through additional interfaces
- Various IP protocols: SNMP, ICMP (Ping), NTP, FTP ...
- Up to 4 ports simultaneous



### Measuring device homepage

- Web server on the measuring device, i.e. device's inbuilt homepage
- Function expansion possible through APPs
- Remote operation of the device display via the homepage
- Comprehensive measurement data incl. PQ (transients, events...)
- Online data directly available via the homepage, historic data optional via the APP measured value monitor, 51.00.245



### BACnet protocol for building communication

- Optimal interoperability between devices from various manufacturers
- Predefined BIBBs (BACnet Interoperability Building Block)
- BACnet is optionally available with UMG 512-PRO
- UMG 512-PRO supports the device type B-SA with the BIBBs DS-RP-B and DS-WP-B
- Furthermore, the BIBBs DS-COV-B and DM-UTC-B are also supported



### Modbus Gateway function

- Economical connection of subordinate measuring devices without Ethernet interface
- Integration of devices with Modbus-RTU interface possible (harmonisation of data format and function code necessary)
- Data can be scaled and described
- Minimised number of IP addresses required
- Tried and tested integrated solution without additional hardware



### Programming / PLC functionality

- Further processing of the measurement data in the measuring device (local intelligence)
- Monitoring and alarm functions simple to program
- Sustainable functional expansions far beyond pure measurement
- Comprehensive programming options with
  - Jasic® source code programming
  - Graphical programming
- Complete APPs from the Janitza library

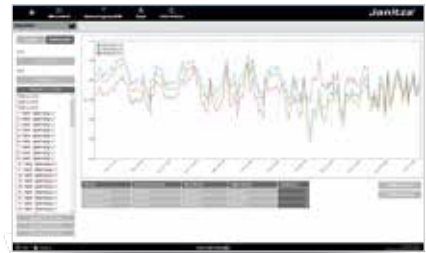


Fig.: Illustration of the historic data via the homepage (APP measurement monitor)

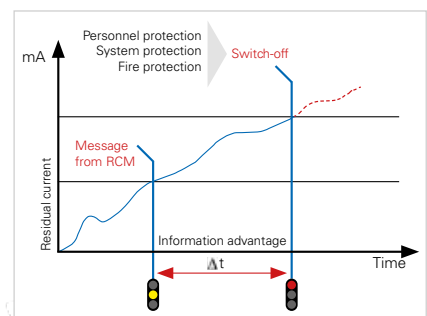


Fig.: Report prior to switching off – an aim of residual current monitoring



Abb.: Replacing the battery using long-nose pliers



### Large measurement data memory

- 256 MB data memory
- Memory range up to 2 years (configuration-dependent)
- Individually configurable recordings
- Recording averaging times can be freely selected
- PQ recordings template preconfigured for conventional standards (e.g. EN 50160)
- User-defined memory segmenting possible



### Powerful alarm management

- Information available immediately by email
- Inform maintenance personnel via the powerful device homepage
- Via digital outputs, Modbus addresses, GridVis® Power Grid Monitoring Software
- Programming via Jasic® or graphical programming
- Further alarm management functions via GridVis®-Service alarm management



### Peak load representation

- Illustration of the 3 highest monthly power peaks on the LCD display (P, Q, S)
- Rolling bar chart representation of the peak power values over 3 years on the LCD display (P, Q, S)
- Plain text representation on the LCD display (P)



### GridVis® Essentials – Power Grid Monitoring Software

- Multilingual
- Manual read-out of the measuring devices
- Manual report generation (power quality and energy consumption reports)
- Comprehensive PQ analysis with individual graphs
  - Online graphs
  - Historic graphs
  - Graph sets
- Integrated databases (Janitza DB, Derby DB)
- Graphical programming
- Topology views
- High memory range

### Certified quality through independent institutes

- ISO 9001
- Energy management certified according to ISO 50001
- Class A certificate (IEC 61000-4-30)
- UL certificate
- EMC-tested product



Abb.: Heatmap – total number of breaches of EN 50160



Fig.: GridVis® alarm management, alarm list (logbook)

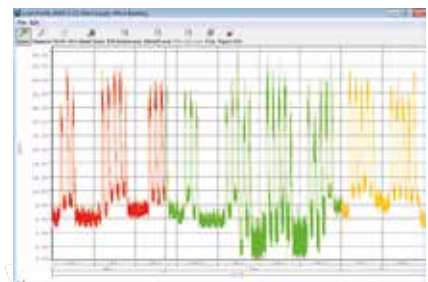


Fig.: GridVis® load profile, asic instrument for EnMS

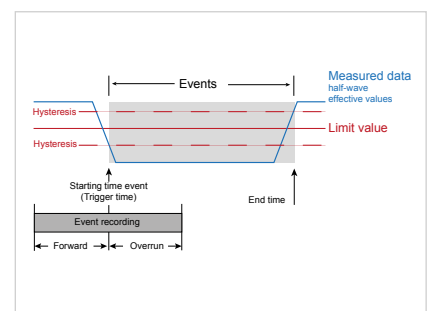
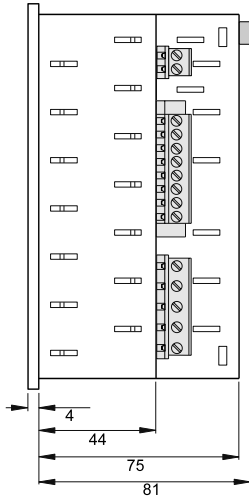


Fig.: The event record consists of a mean value, a minimum or maximum value, a start time and an end time.

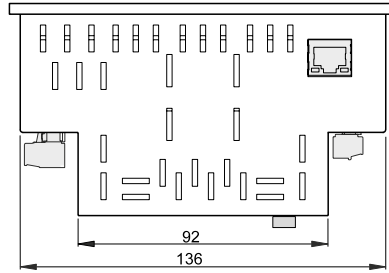


## Dimension diagrams

All dimensions in mm



Side view



View from below

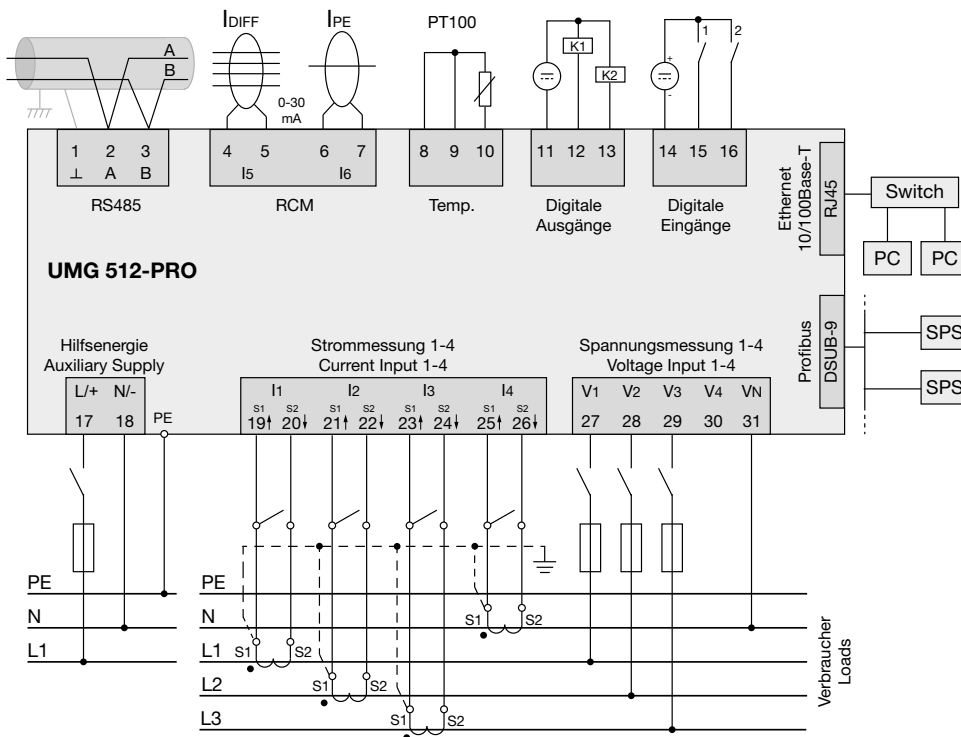


Rear view

Cut out:  $138^{+0,8} \times 138^{+0,8}$  mm



## Typical connection







## Device overview and technical data

Item number	UMG 512-PRO	
	52.17.011	52.17.003
AC supply voltage	95 to 240 V AC	48 to 110 V AC
Supply voltage DC	80 to 300 V DC	24 to 150 V DC
<b>Device options</b>		
BACnet communication	52.17.081	52.17.081

General	
Net weight (with attached connectors)	approx. 1080 g (2.38 lb)
Device dimensions (W x H x D)	approx. 144 x 144 x 75 mm (5.64 x 5.64 x 2.95 in)
Battery	type Li-Mn CR2450, 3 V (approval i.a.w. UL 1642)
Clock (temperature range -40 °C to +85 °C)	+5 ppm (corresponding to approx. 3 minutes per year)
Impact resistance	IK07 according to IEC 62262

Transport and storage	
The following information applies to devices which are transported or stored in the original packaging.	
Free fall	1 m (39.37 in)
Temperature	-25 °C to +70 °C (-13 °F up to 158 °F)

Ambient conditions during operation	
The device is intended for weatherproof, fixed installation and must be connected to the ground wire connection! Protection class I in acc. with IEC 60536 (VDE 0106, Part 1).	
Working temperature range	-10 °C to +55 °C (14 °F to 131 °F)
Relative humidity	5 to 95 % (at 25 °C/77 °F) without condensation
Operating altitude	0 to 2000 m (1.24 mi) above sea level
Pollution degree	2
Installation position	upright
Ventilation	forced ventilation is not required.
Protection against ingress of solid foreign bodies and water - Front - Rear	IP40 in acc. with EN60529 IP20 in acc. with EN60529

Supply voltage	
Installations of overvoltage category	300 V CAT III
Protection of the supply voltage (fuse)	6 A, type C (approved i.a.w. UL/IEC)
230 V option: - Nominal range - Operating range - Power consumption	95 V to 240 V (50/60 Hz) / DC 80 V to 300 V ± 10 % of nominal range max. 7 W / 14 VA
24 V option: - Nominal range - Operating range - Power consumption	48 V to 110 V (50/60 Hz) / DC 24 to 150 V ± 10 % of nominal range max. 9 W / 13 VA

Terminal connection capacity (supply voltage)	
Connectable conductors. Only one conductor can be connected per terminal!	
Single core, multi-core, fine-stranded	0,2 – 4 mm <sup>2</sup> , AWG 28 - 12
Cable end sleeve (not insulated)	0,2 – 2,5 mm <sup>2</sup> , AWG 26 - 14
Cable end sleeve (insulated)	0,2 – 2,5 mm <sup>2</sup> , AWG 26 - 14
Tightening torque	0,4 – 0,5 Nm (3.54 – 4.43 lbf in)
Stripping length	7 mm (0.2756 in)

<b>Current measurement</b>	
Rated current	5 A
Resolution	0.1 mA
Metering range	0.005 to 7 A <sub>rms</sub>
Measurement range exceeded (overload)	as of 8.5 A <sub>rms</sub>
Crest factor	1.41
Overvoltage category	230 V option: 300 V CAT III 24 V option: 300 V CAT II
Measurement voltage surge	4 kV
Power consumption	approx. 0.2 VA (Ri = 5 mOhm)
Overload for 1 sec.	120 A (sinusoidal)
Sampling rate	25.6 kHz / phase

<b>Voltage measurement</b>	
The voltage measurement inputs are suitable for measurements in the following power supply systems:	
Three-phase 4-conductor systems with rated voltages up to	417 V / 720 V (+10%) 347 V / 600 V (UL listed)
Three-phase 3-conductor systems with rated voltages up to	600 V (+10%)
From a safety and reliability perspective, the voltage measurement inputs are designed as follows:	
Overvoltage category	600 V CAT III
Measurement voltage surge	6 kV
Protection of voltage measurement	1-10 A
Metering range L-N	0 <sup>1)</sup> to 600 V <sub>rms</sub>
Metering range L-L	0 <sup>1)</sup> to 1000 V <sub>rms</sub>
Resolution	0.01 V
Crest factor	1.6 (related to 600 V <sub>rms</sub> )
Impedance	4 MOhm / phase
Power consumption	approx. 0.1 VA
Sampling rate	25.6 kHz / phase
Transients	39 µs
U <sub>din</sub> <sup>2)</sup> as per EN61000-4-30	100 to 250 V
Flicker range (dU/U)	27.5 %
Frequency of the fundamental oscillation - Resolution	15 Hz to 440 Hz 0.001 Hz


1 ) The device can only determine measured values, if an L-N voltage of greater than 10 V<sub>eff</sub> or an L-L voltage of greater than 18 V<sub>eff</sub> is applied to at least one voltage measurement input.

2) U<sub>din</sub> = arranged input voltage according to DIN EN 61000-4-30

<b>Phase angle accuracy of measurement</b>	0.075°
--	--------

<b>Terminal connection capacity (voltage measurement)</b>	
Connectable conductors. Only one conductor can be connected per terminal!	
Single core, multi-core, fine-stranded	0.2 – 4 mm <sup>2</sup> , AWG 28 - 12
Cable end sleeve (not insulated)	0.2 – 4 mm <sup>2</sup> , AWG 26 - 14
Cable end sleeve (insulated)	0.2 – 2.5 mm <sup>2</sup> , AWG 26 - 14
Tightening torque	0.4 – 0.5 Nm (3.54 – 4.43 lbf in)
Stripping length	7 mm (0.2756 in)

<b>Terminal connection capacity (current measurement)</b>	
Connectable conductors. Only one conductor can be connected per terminal!	
Single core, multi-core, fine-stranded	0.2 – 4 mm <sup>2</sup> , AWG 28 - 12
Cable end sleeve (not insulated)	0.2 – 4 mm <sup>2</sup> , AWG 26 - 12
Cable end sleeve (insulated)	0.2 – 2.5 mm <sup>2</sup> , AWG 26 - 14
Tightening torque	0.4 – 0.5 Nm (3.54 – 4.43 lbf in)
Stripping length	7 mm (0.2756 in)

Residual current monitoring (RCM)	
Rated current	30 mA <sub>rms</sub>
Metering range	0 to 40 mA <sub>rms</sub>
Triggering current	100 µA
Resolution	1 µA
Crest factor	1.414 (related to 40 mA)
Burden	4 Ohm
Overload for 1 sec.	5 A
Sustained overload	1 A
Overload for 20 ms	50 A
Residual current monitoring	i.a.w. IEC/TR 60755 (2008-01), type A 
Maximum external burden	300 Ohm (for cable break detection)

Terminal connection capacity (residual current monitoring)	
Connectable conductors. Only one conductor can be connected per terminal!	
Single core, multi-core, fine-stranded	0.2 – 1.5 mm <sup>2</sup> , AWG 28 - 16
Cable end sleeve (not insulated)	0.2 – 1.5 mm <sup>2</sup> , AWG 26 - 16
Cable end sleeve (insulated)	0.2 – 1.5 mm <sup>2</sup> , AWG 26 - 16
Tightening torque	0.2 – 0.25 Nm (1.77 – 2.21 lbf in)
Stripping length	7 mm (0.2756 in)
Cable length	up to 30 m (32.81 yd) unshielded, from 30 m (32.81 yd) shielded

Potential separation and electrical safety for the residual current monitoring inputs	
<ul style="list-style-type: none"> <li>- The RCM measurement inputs are double-insulated from the current and voltage measurement inputs, as well as the supply voltage.</li> <li>- There is no insulation from the thermistor input.</li> <li>- There is only a functional insulation from the Ethernet, Profibus and RS485 interfaces and the digital I/Os.</li> <li>- The residual current transformer connected and the lines to be measured must each have at least one additional or basic insulation per IEC61010-1:2010 for the mains voltage present.</li> </ul>	

Temperature measurement input	
3-wire measurement	
Update time	1 second
Connectable sensors	PT100, PT1000, KTY83, KTY84
Total burden (sensor + cable)	max. 4 kOhm
Cable length	up to 30 m (32.81 yd) unshielded, from 30 m (32.81 yd) shielded

Sensor type	Temperature range	Resistor range	Measurement uncertainty
KTY83	-55° C to +175° C (-67 °F ..to 347 °F)	500 Ohm to 2.6 kOhm	±1.5% rng
KTY84	-40° C to +300° C (-40 °F ..to 572 °F)	350 Ohm to 2.6k Ohm	±1.5% rng
PT100	-99° C to +500° C (-146.2 °F ..to 932 °F)	60 Ohm to 180 Ohm	±1.5% rng
PT1000	-99° C to +500° C (-146.2 °F ..to 932 °F)	600 Ohm to 1.8k Ohm	±1.5% rng

Terminal connection capacity (thermistor input)	
Connectable conductors. Only one conductor can be connected per terminal!	
Single core, multi-core, fine-stranded	0.2 – 1.5 mm <sup>2</sup> , AWG 28 - 16
Cable end sleeve (not insulated)	0.2 – 1.5 mm <sup>2</sup> , AWG 26 - 16
Cable end sleeve (insulated)	0.2 – 1.5 mm <sup>2</sup> , AWG 26 - 16
Tightening torque	0.2 – 0.25 Nm (1.77 – 2.21 lbf in)
Stripping length	7 mm (0.2756 in)

Potential separation and electrical safety for the thermistor inputs	
<ul style="list-style-type: none"> <li>- The thermistor input is double-insulated from the current and voltage measurement inputs, as well as the supply voltage.</li> <li>- There is no insulation from the RCM measurement input.</li> <li>- There is only a functional insulation from the Ethernet, Profibus and RS485 interfaces and the digital I/Os.</li> <li>- The external temperature sensor must be double insulated from the system parts that carry voltages that are dangerous to touch (per IEC61010-1:2010).</li> </ul>	

## Chapter 02

### UMG 512-PRO

<b>Digital inputs</b>	
2 Digital inputs with a joint earth	
Maximum counter frequency	20 Hz
Response time (Jasic program)	200 ms
Input signal present	18 V to 28 V (typically 4 mA) (SELV or PELV supply)
Input signal not present	0 to 5 V DC, current less than 0.5 mA
Cable length	up to 30 m (32.81 yd) unshielded, from 30 m (32.81 yd) shielded

<b>Digital outputs</b>	
2 digital outputs with a joint earth; opto coupler, not short-circuit proof	
Supply voltage	20 V - 30 V DC (SELV or PELV supply)
Switching voltage	max. 60 V DC
Switching current	max. 50 mAeff AC/DC
Response time (Jasic program)	200 ms
Switching frequency	max. 20 Hz
Cable length	up to 30 m (32.81 yd) unshielded, from 30 m (32.81 yd) shielded

<b>Terminal connection capacity (digital inputs and outputs)</b>	
Connectable conductors. Only one conductor can be connected per terminal!	
Single core, multi-core, fine-stranded	0.2 – 1.5 mm <sup>2</sup> , AWG 28 - 16
Cable end sleeve (not insulated)	0.2 – 1.5 mm <sup>2</sup> , AWG 26 - 16
Cable end sleeve (insulated)	0.2 – 1.5 mm <sup>2</sup> , AWG 26 - 16
Tightening torque	0.2 – 0.25 Nm (1.77 – 2.21 lbf in)
Stripping length	7 mm (0.2756 in)

<b>Potential separation and electrical safety for the digital inputs and outputs</b>	
<ul style="list-style-type: none"> <li>-The digital inputs and outputs are double-insulated from the current and voltage measurement inputs, as well as the supply voltage.</li> <li>-There is only a functional insulation from the Ethernet, Profibus and RS485 interfaces and the digital I/Os, and from one another.</li> <li>-The external auxiliary voltage to be connected must be compliant with SELV or PELV.</li> </ul>	

<b>RS485 interface</b>	
3-wire connection with GND, A, B	
Protocol	Modbus RTU/slave, Modbus RTU/master, Modbus RTU /gateway
Transmission rate	9.6 kbps, 19.2 kbps, 38.4 kbps, 57.6 kbps, 115.2 kbps, 921.6 kbps
Termination resistor	can be activated by micro switch

<b>Terminal connection capacity (serial interface - RS485)</b>	
Connectable conductors. Only one conductor can be connected per terminal!	
Single core, multi-core, fine-stranded	0.2 – 1.5 mm <sup>2</sup> , AWG 28 - 16
Cable end sleeve (not insulated)	0.2 – 1.5 mm <sup>2</sup> , AWG 26 - 16
Cable end sleeve (insulated)	0.2 – 1.5 mm <sup>2</sup> , AWG 26 - 16
Tightening torque	0.2 – 0.25 Nm (1.77 – 2.21 lbf in)
Stripping length	7 mm (0.2756 in)

<b>Profibus interface</b>	
Connection	SUB D 9-pole
Protocol	Profibus DP/V0 per EN 50170
Transmission rate	9.6 kBaud to 12 MBaud

<b>Ethernet interface</b>	
Connection	RJ45
Function	Modbus gateway, embedded web server (HTTP)
Protocols	CP/IP, EMAIL (SMTP), DHCP client (BootP), Modbus/TCP, Modbus RTU over Ethernet, FTP, ICMP (Ping), NTP, TFTP, BACnet (optional), SNMP

Comment: For detailed technical information please refer to the operation manual and the Modbus address list.

<b>Firmware</b>	
Firmware update	Please observe the operating instructions

**Potential separation and electrical safety for the interfaces**

- The Ethernet, Profibus and RS485 interfaces are double-insulated from the current and voltage measurement inputs, as well as the supply voltage.
- There is only a functional insulation from the RSM measurement inputs and thermistor inputs, as well as from the digital I/Os and from one another.
- The interfaces for the devices connected here must have a double or reinforced insulation to mains voltages (in accordance with IEC 61010-1: 2010).



# MRG 96RM-E RCM Flex & MRG 512-PRO PQ Flex



**Communication**

- Modbus over TCP/IP
- BACnet (optional)
- HTTP
- FTP (File-Transfer)
- TFTP
- NTP (Zeitsynchronisierung)
- SMTP (E-Mail-Funktion)
- DHCP
- SNMP

**Interfaces**

- Ethernet 10/100Base-TX

**RCM – Residual Current Monitoring**

- 2 residual current inputs

**Power quality**

- Harmonics up to the 40th (MRG 96RM-E) or 63rd (MRG 512-PRO) harmonic
- Distortion factor THD-U / THD-I / TDD
- Measurement of positive, negative and zero sequence component (only MRG 512-PRO)
- Direction of rotation field
- Acquisition of short-term interruptions
- Transient recorder, 39  $\mu$ s (only MRG 512-PRO)
- Starting currents (from 20 ms)
- Unbalance (only MRG 512-PRO)
- Flicker measurement per EN 61000-4-15 (only MRG 511 Flex)
- Display of waveforms (only MRG 512-PRO)

**Buffered UPS (only MRG 512-PRO)**

- Up to 3 hrs

**PLC functionality (only MRG 512-PRO)**

- Graphical programming
- Jasic® programming language

**Networks**

- TN, TT networks
- 3 and 4-phase networks
- Up to 4 single-phase networks

**Power Grid Monitoring Software**

- Free GridVis® Essentials

**Rogowski coil (300 mm)**

- 100 – 4.000 A
- Measured range 250 A, 500 A, 1000 A, 2000 A, 4000 A



## Areas of application



- High quality PQ analysis at class A level (IEC 61000-4-30)
- Temporary measurement e.g. for the design of power factor correction systems
- Analysis of electrical disturbances in the event of PQ problems
- Fault analysis with power quality problems
- High quality comparative measurement of energy measurement devices and meters
- Calibration of measurement devices (ISO 50001 audit)
- Recording of residual currents over an external current transformer (not included in the scope of delivery)

## Main features

- Monitoring of the power quality
- Capturing of all power quality parameters (harmonics, short-term interruptions, asymmetries etc.)
- Remote access via Ethernet and embedded web server
- GridVis® Power Grid Monitoring Software
- Standard PQ reports, depending on the version:  
EN 50160 , IEEE519, ITIC, EN 61000-2-4
- Cost centre report
- Large 256 MB internal memory for storing measurement data
- UPS-supported power supply for up to 3 hours



Fig.: MRG 512-PRO PQ Flex – Portable power quality analyser with RCM (Image similar)



### MRG 512-PRO PQ Flex: User-friendly, colour graphical display with intuitive user guidance

- High resolution graphics display
- User-friendly, self-explanatory and intuitive operation
- Clear and informative representation of online graphs and further power quality events



### Modern communications architecture via Ethernet

- Ethernet interface and web server
- Faster, better cost-optimised and more reliable communication system
- High flexibility due to the use of open standards



Fig.: MRG 96RM-E RCM Flex – Portable energy measurement device with RCM (Image similar)



### Large measurement data memory

- 256 MByte
- Recording range of up to 2 years, depending on the recording configuration
- Recording freely configurable





### RCM (Residual Current Monitoring)

- Continuous monitoring of residual currents (Residual Current Monitoring, RCM)
- Alarming in case a preset threshold fault current reached
- Near-realtime reactions for triggering countermeasures
- Permanent RCM measurement for systems in permanent operation without the opportunity to switch off
- Ideal for the central earthing point in TN-S systems



### Graphical programming (only MRG 512-PRO)

- Comprehensive programming options (PLC functionality)
- Jasic® source code programming
- Sustainable functional expansions far beyond pure measurement
- Complete APPs from the Janitza library

### Scope of delivery for the MRG product range

- Compact, robust plastic housing with measurement device and all connections
- UPS-supported power supply for up to 3 hours
- Supplementary description for each measurement device
- Operation manual for each measurement device
- DVD with following content:
  - Power Grid Monitoring Software GridVis® Essentials
  - Functional description - GridVis®
- Carry soft bag for accessories
- Mains connection cable
- 1 Crossover patch cable, CAT5e
- 1 set of voltage measuring cables with fuses (brown, black, grey, blue, green/yellow)
- Voltage tap-offs
- 2 connection cable 3 m for residual current measuring with connector
- Incl. Rogowski coil Ø 95 mm, length 300 mm (MRG 96RM-E RCM Flex); Ø 175 mm, length 600 mm (MRG 512-PRO PQ Flex)

### Optional accessories:

Differential current transformer on request.

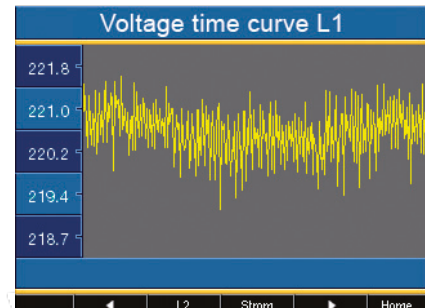


Fig.: Colour graphical display MRG 512-PRO PQ Flex – Example voltage profile over time

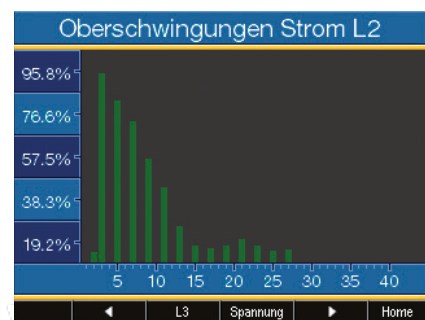


Fig.: Colour graphical display MRG 512-PRO PQ Flex – Example harmonics analysis



Fig.: Measurement connection for current transformer and voltage; auxiliary voltage and ethernet connection



## Device overview and technical data

	MRG 96RM-E RCM Flex	MRG 512-PRO PQ Flex
<b>Item number</b>	52.16.906	52.16.905
<b>Interfaces</b>		
Ethernet 10/100 Base-TX (RJ-45 socket)	•	•
<b>Measurement of the power quality</b>		
Harmonics per order / current and voltage	1 – 40.	1 – 63.
Harmonics per order / active and reactive power	1 – 40.	1 – 63.
Interharmonics - current / voltage	-	•
Flicker: Short term, long term, present	-	•
<b>Measurement data recording</b>		
Memory (Flash)	256 MB	256 MB
<b>Measured voltage input</b>		
Overvoltage category	600 V CAT III	600 V CAT III
<b>Displays and inputs / outputs</b>		
LCD display	LCD display with backlight, 2 buttons	Colour graphical display 320 x 240, 256 colours, 6 buttons

	MRG 96RM-E RCM Flex	MRG 512-PRO PQ Flex
<b>General</b>		
Use in low and medium voltage networks	•	•
Accuracy of measurement with voltage	0.2 %	0.1%
Accuracy of measurement with current	0.2 %	0.1%
Accuracy of measurement with active energy (kWh, .../5 A)	Class 0.5S	Class 0.2S
Number of measurement points per period	426	512
Uninterrupted measurement	•	•
<b>RMS - momentary value</b>		
Current, voltage, frequency	•	•
Active, reactive and apparent power / total and per phase	•	•
Power factor / total and per phase	•	•
<b>Energy measurement</b>		
Active, reactive and apparent energy [L1, L2, L3, L4, Σ L1-3, Σ L1-4]	•	•
<b>Recording of the mean values</b>		
Voltage, current / present and maximum	•	•
Active, reactive and apparent power / present and maximum	•	•
Frequency / present and maximum	•	•
Requirement calculation mode (bi-metallic function) / thermal	•	•
<b>Other measurements</b>		
Operating hours measurement	•	•
Clock	•	•
<b>Measurement of the power quality</b>		
Distortion factor THD-U in %	•	•
Distortion factor THD-I in %	•	•
Current and voltage, positive, zero and negative sequence component	•	•
Transients	-	> 39 μs
Error / event plotter function	•	•
Short term interruptions	-	•
Oscillogram function (wave form U and I)	-	•
Under and overvoltage recording	•	•
<b>Measurement data recording</b>		
Mean, minimum, maximum values	•	•
Alarm messages	•	•
Time stamp	•	•
Time basis mean value	freely user-defined	freely user-defined
RMS averaging, arithmetic	•	•
<b>Displays and inputs / outputs</b>		
Analogue inputs (RCM, analogue)	•	•
Voltage and current inputs	L1, L2, L3 + N	every 4
Password protection	•	•

Comment:  
For detailed technical information,  
please refer to the operation manual  
and the Modbus address list.

• = included  
- = not included



Fig.: Rogowski coil with measurement transducer



Fig.: Voltage taps

**Comment:**  
For detailed technical information, please refer to the operation manual and the Modbus address list.

• = included  
- = not included

\*<sup>1</sup> Additional functions can be purchased with the GridVis® Standard or Expert editions.

\*<sup>2</sup> The UMG 96RM-E can only determine measured values if a voltage L1-N greater than 20 V<sub>eff</sub> (4-wire measurement) or a voltage L1-L2 greater than 34 V<sub>eff</sub> (3-wire measurement) is applied at the voltage measurement input V1.

\*<sup>3</sup> The UMG 512-PRO can only determine measured values, if an L-N voltage of greater than 10 V<sub>eff</sub> or an L-L voltage of greater than 18 V<sub>eff</sub> is applied to at least one voltage measurement input.

	MRG 96RM-E RCM Flex	MRG 512-PRO PQ Flex
<b>Protocols</b>		
Modbus TCP, Modbus RTU over Ethernet	•	•
HTTP (homepage configurable)	•	•
SMTP (email)	•	•
NTP (time synchronisation)	•	•
TFTP (automatic configuration)	•	•
FTP (file transfer)	•	•
SNMP	•	•
DHCP	•	•
TCP/IP	•	•
BACnet (optional)	•	•
ICMP (Ping)	•	•
<b>GridVis® Essentials Power Grid Monitoring Software*<sup>1</sup></b>		
Device configuration	•	•
Graph function	•	•
Device overview	•	•
Event browser	•	•
Basic data exports	-	•
RCM data exports	•	•
<b>Programming / threshold values / alarm management</b>		
Application programs freely programmable	-	7
Graphical programming	-	•
Programming via source code Jasic®	-	•
Comparator (5 Groups with 10 comparators each)	•	-
<b>Technical data</b>		
Nominal voltage, three-phase, 4-conductor (L-N, L-L)	277 / 480 V AC	417 / 720 V AC
Nominal voltage, three-phase, 3-conductor (L-L)	480 V AC	600 V AC
Measurement in which quadrants	4	4
<b>Networks</b>		
Measurement in single-phase/multi-phase networks	1 ph, 2 ph, 3 ph, 4 ph	1 ph, 2 ph, 3 ph, 4 ph and up to 4 times 1 ph
<b>Measured voltage input</b>		
Metering range, voltage L-N, AC (without transformer)	0 <sup>2</sup> to 300 V <sub>rms</sub>	0 <sup>3</sup> to 600 V <sub>rms</sub>
Metering range, voltage L-L, AC (without transformer)	0 <sup>2</sup> to 520 V <sub>rms</sub>	0 <sup>3</sup> to 1000 V <sub>rms</sub>
Resolution	0.01 V	0.01 V
Impedance	3 MOhm / phase	4 MOhm / phase
Frequency measuring range	45 to 65 Hz	15 to 440 Hz
Power consumption	approx. 0.1 VA	approx. 0.1 VA
<b>Measured current input</b>		
Rated current	5 A	5 A
Resolution	0.1 mA	0.1 mA
Metering range	0.005 - 6 A <sub>rms</sub>	0.005 - 7 A <sub>rms</sub>
Overvoltage category	300 V CAT II	300 V CAT III
Measurement voltage surge	2 kV	6 kV
Power consumption	approx. 0.2 VA (R <sub>i</sub> = 5 mOhm)	approx. 0.1 VA (R <sub>i</sub> = 5 MOhm)
Overload for 1 sec.	120 A (sinusoidal)	120 A (sinusoidal)
Sampling rate	20 kHz	25.6 kHz
<b>Mechanical properties</b>		
Weight	approx. 3.4 kg	approx. 14.2 kg
Device dimensions in mm (L x W x H)	350 x 295 x 150	Approx. 500 x 390 x 230
Protection class per EN 60529	Front: IP40; Back: IP20	Front: IP40; Back: IP20
<b>Safety</b>		
Europe	CE labelling	CE labelling

## 03 Energy management

### MID energy meters

Page 165

- Digital pulse transducer or communication at field bus level
- Measurement of reactive or active energy consumption
- MID-certified

### ProData® data logger

Page 175

- Compact and universal data logger
- Acquisition of electrical and non electrical values
- Modbus Ethernet Gateway functionality enables simple integration of slave devices

### Field bus modules series FBM

Page 181

- Decentralised I/O field bus modules
- Connection with master devices via RS485 interface
- Seamless recording of various measurement and process data



GridVis®



2 tariffs



MID



Pulse output



Modbus



M-Bus

## MID ENERGY METERS





## Areas of application

- Energy management
- Cost centre analysis
- Measured value transducer for PLC controls or building management systems (BMS)
- For energy billing purposes

## Main features

- Communication: Modbus, M-Bus, S0 pulse outputs
- Direct measurement up to 65 A, transformer measurement up to 6 A, secondary (CT ration freely adjustable)
- 1 or 2 tariffs
- 4-quadrant measurement
- Class 1 for effective energy
- MID and IEC calibrated at the factory
- Lead-sealed terminal cover
- Measured values: Active energy, reactive energy, active power, reactive power
- Precision class 1 for active energy

## Applications

- Logging of active and reactive energy
- S0 pulse outputs, proportional to energy flowing, can be connected to a control system PLC, SCADA system or data logger
- Integrated interface makes available protocols such as M-Bus or Modbus RTU
- Measurements of 1 and 3-phase systems with a voltage of L-N 230 V AC / L-L 400 V AC
- Measurement of input currents via direct connection or via current transformer (.../1 A or .../5 A)
- DIN rail installation

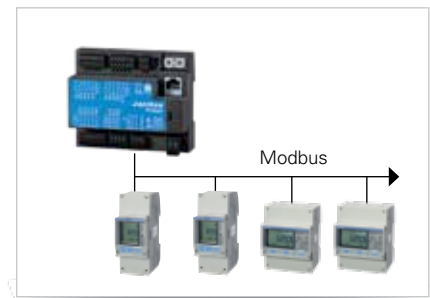


Fig.: Measured energy values are available via the integrated communication interface Modbus RTU.

# MID energy meter B21 – Single-phase energy meter, 65 A

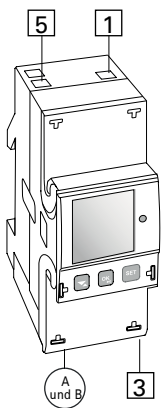
## Single-phase energy meter (1 + N)

- Direct connection up to 65 A
- With measured values and alarm function
- Width, 2 DIN modules
- Tested and approved per MID\*1 and IEC
- Pulse output included

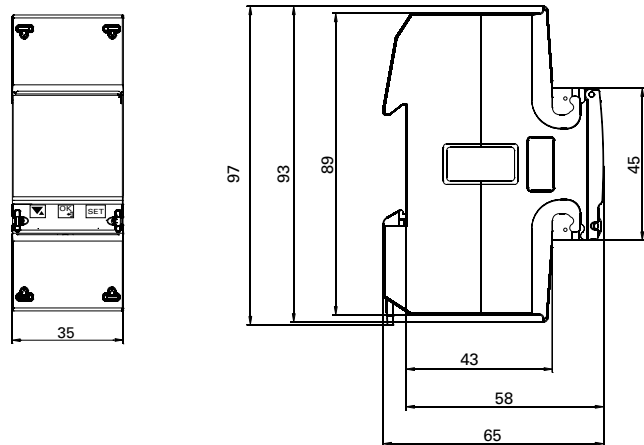


\*1 Regional different requirements apply in Switzerland in connection with MID energy meters.

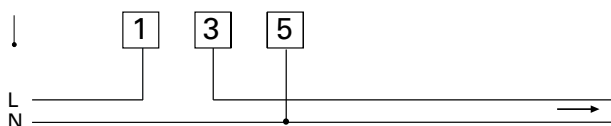
Voltage V	Precision class	Inputs/outputs	Communication	Type	Item no.	Weight
1 x 230 V AC	Active energy: B (class 1) Reactive energy: class 2	2 outputs, 2 inputs	Pulse output	B21 311-10J	14.01.353	0.14
			Pulse output, RS-485	B21 312-10J	14.01.354	0.15
			Pulse output, M-Bus	B21 313-10J	14.01.355	0.15



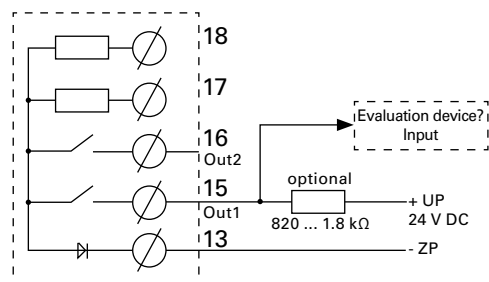
Dimensions in mm



B21 connection terminals



Pulse output S0



# MID energy meter B23 – Three-phase energy meter, direct measurement, 65 A

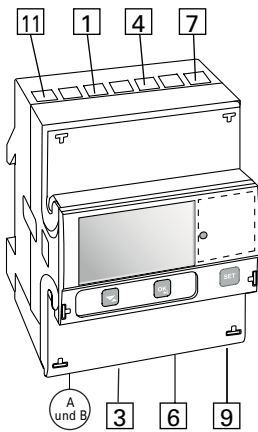
## Three-phase energy meter, direct measurement (3 + N)

- Direct connection up to 65 A
- With measured values and alarm function
- For 3-conductor and 4-conductor connection
- Width, 4 DIN modules
- Tested and approved per MID\*1 and IEC
- Pulse output included

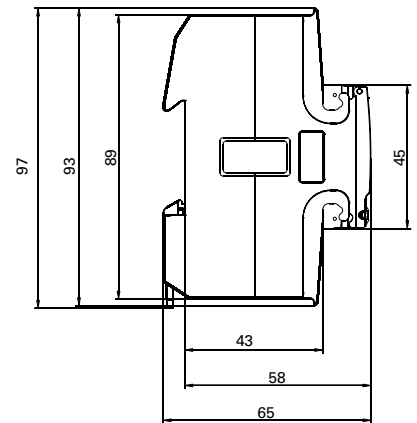
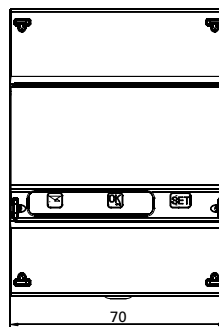


\*1 Regional different requirements apply in Switzerland in connection with MID energy meters.

Voltage V	Precision class	Inputs/outputs	Communication	Type	Item no.	Weight
3 x 230/400 V AC	Active energy: B (class 1) Reactive energy: class 2	2 outputs, 2 inputs	Pulse output	B23 311-10J	14.01.356	0.33
			Pulse output, RS-485	B23 312-10J	14.01.357	0.34
			Pulse output, M-Bus	B23 313-10J	14.01.358	0.35

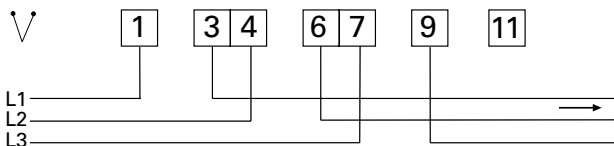


Dimensions in mm

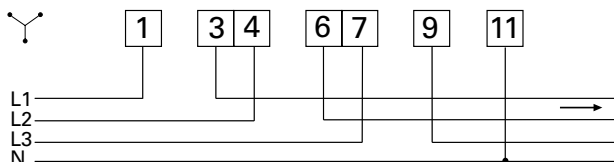


### B23 connection terminals

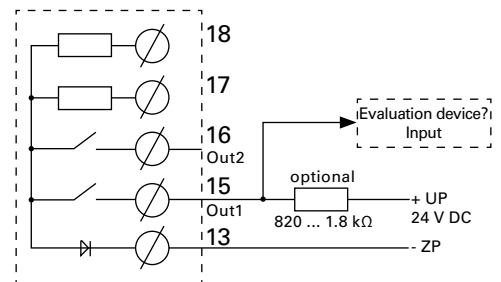
3-conductor connection with 2 measuring units



4-conductor connection with 3 measuring units



### Pulse output S0





# MID energy meter B24 – Three-phase energy meter, CT measurement, 6 A

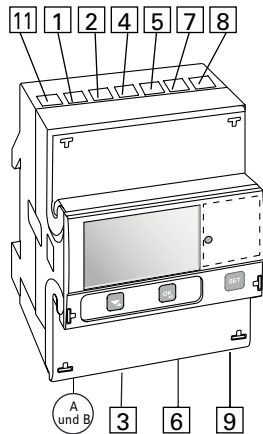
## Three-phase energy meter, CT measurement (3 + N)

- Transformer connection CT, 1(6) A
- Transformer ratio freely adjusted up to 9999/1-6
- With measured values and alarm function
- For 3-conductor and 4-conductor connection
- Width, 4 DIN modules
- Tested and approved per MID\*1 and IEC
- Pulse output included

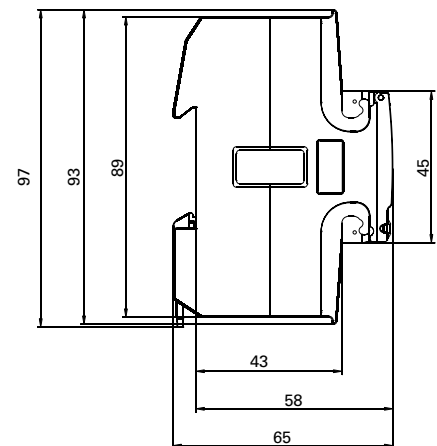
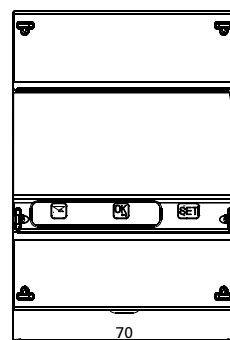


\*1 Regional different requirements apply in Switzerland in connection with MID energy meters.

Voltage V	Precision class	Inputs/outputs	Communication	Type	Item no.	Weight
3 x 230/400 V AC	Active energy: B (class 1) Reactive energy: class 2	2 outputs, 2 inputs	Pulse output	B24 311-10J	14.01.359	0.27
			Pulse output, RS-485	B24 312-10J	14.01.360	0.27
			Pulse output, M-Bus	B24 313-10J	14.01.361	0.29

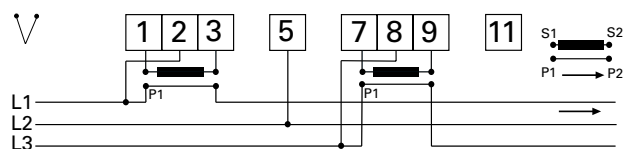


Dimensions in mm

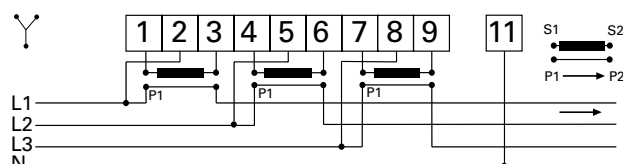


## B24 connection terminals

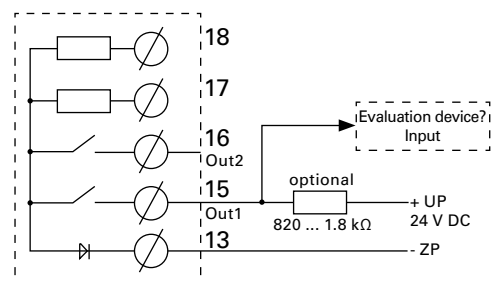
### 3-conductor connection with 2 measuring units



### 4-conductor connection with 3 measuring units



## Pulse output S0



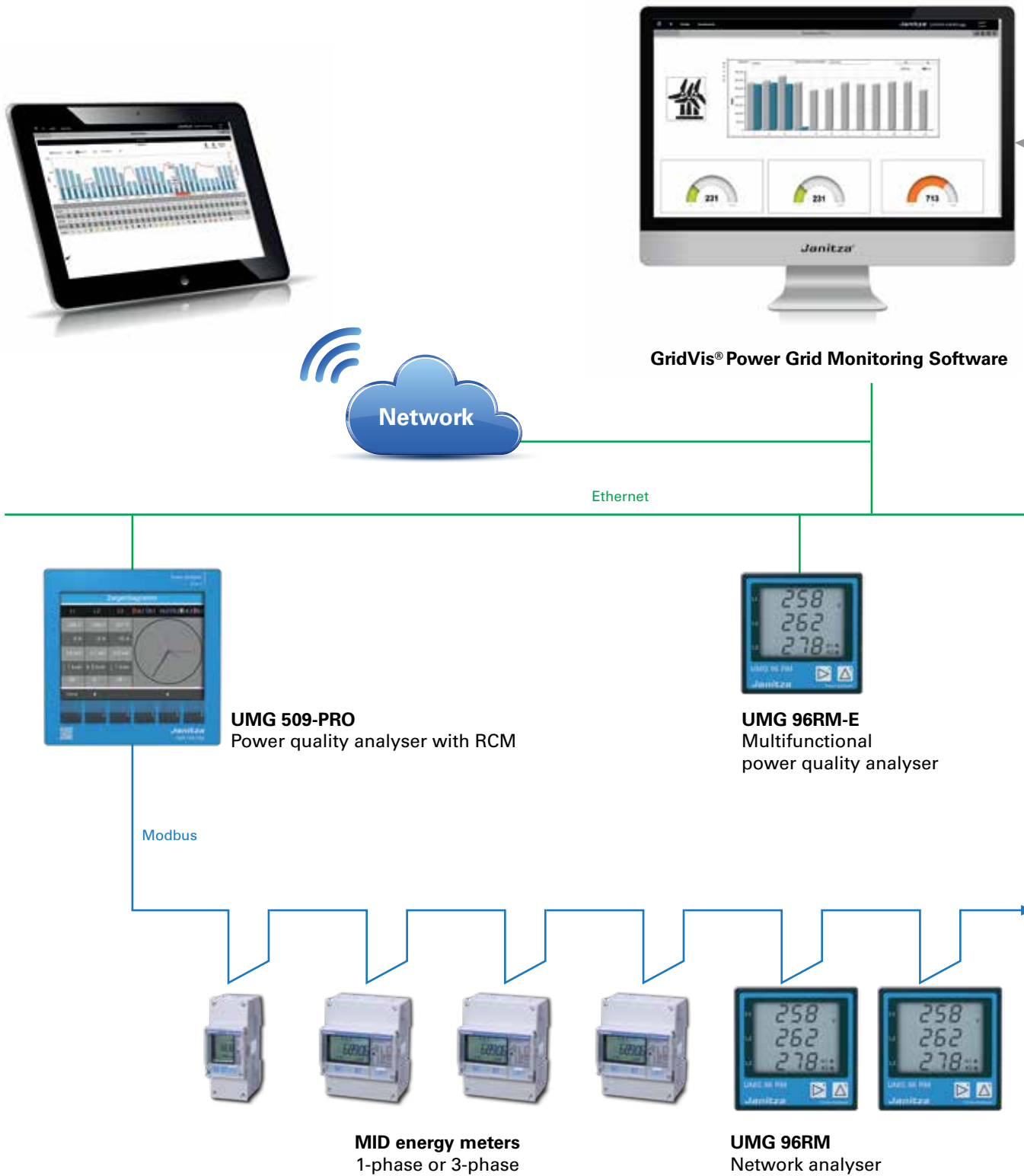


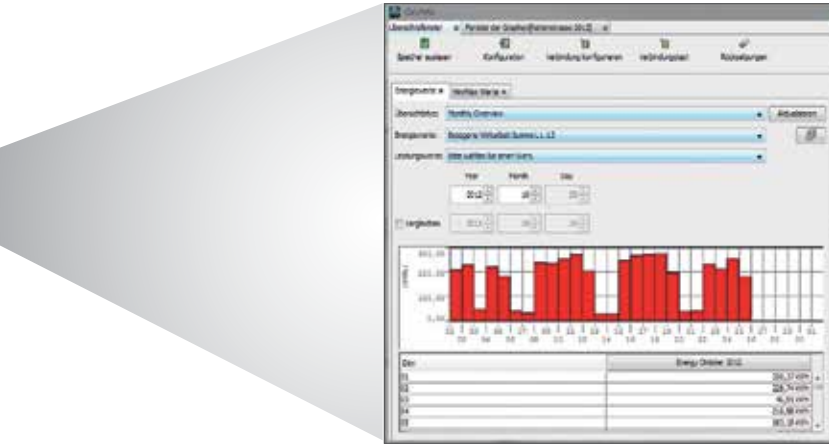
## Device overview and technical data

	B21 Single-phase energy meter	B23 Three-phase energy meter, direct measurement	B24 Three-phase energy meter, CT measurement
<b>Voltage/current inputs</b>			
Rated voltage	230 V AC	3 x 230/400 V AC	3 x 230/400 V AC
Voltage range	220 – 240 V AC (–20% – +15%)	3 x 220 – 240 V AC (–20% – +15%)	3 x 220 – 240 V AC (–20% – +15%)
Power dissipation, voltage circuits	1.0 VA (0.4 W) total	1.6 VA (0.7 W) total	1.6 VA (0.7 W) total
Power dissipation, current circuits	0.007 VA (0.007 W) at 230 V AC and $I_b$	0.007 VA (0.007 W) per phase at 230 V AC and $I_b$	0.007 VA (0.007 W) per phase at 230 V AC and $I_b$
Reference current $I_{ref}$	5 A	5 A	1 A
Transition current $I_{tr}$	0.5 A	0.5 A	0.05 A
Max. current $I_{max}$	65 A	65 A	6 A
Min. current $I_{min}$	0.25 A	0.25 A	0.02 A
Start-up current $I_{st}$	< 20 mA	< 20 mA	< 1 mA
Connection cross-section	1 – 25 mm <sup>2</sup>	1 – 25 mm <sup>2</sup>	0.5 – 10 mm <sup>2</sup>
Recommended tightening torque	3 Nm	3 Nm	1.5 Nm
<b>Transformer ratio</b>			
Configurable current ratio (CT)	–	–	9999/1-6
<b>Pulse display (LED)</b>			
Pulse frequency	1000 imp/kWh	1000 imp/kWh	5000 imp/kWh
Pulse length	40 ms	40 ms	40 ms
<b>General information</b>			
Frequency	50 or 60 Hz ± 5%	50 or 60 Hz ± 5%	50 or 60 Hz ± 5%
Precision class	B (cl. 1) and reactive power cl. 2	B (cl. 1) and reactive power cl. 2	B (cl. 1) and reactive power cl. 2
Effective power	1%	1%	0,5%, 1%
Energy display	LCD with 6 digits	LCD with 7 digits	LCD with 7 digits
<b>Environmental</b>			
Operating temperature	-40 °C – +70 °C	-40 °C – +70 °C	-40 °C – +70 °C
Storage temperature	-40 °C – +85 °C	-40 °C – +85 °C	-40 °C – +85 °C
Humidity	75% annual average, 95% on 30 days/year	75% annual average, 95% on 30 days/year	75% annual average, 95% on 30 days/year
Fire and heat resistance	Terminal 960 °C, covering 650 °C (IEC 60695-2-1)	Terminal 960 °C, covering 650 °C (IEC 60695-2-1)	Terminal 960 °C, covering 650 °C (IEC 60695-2-1)
Water and dust resistance	IP20 on terminal strip without protective housing and IP51 in protective housing, per IEC 60529	IP20 on terminal strip without protective housing and IP51 in protective housing, per IEC 60529	IP20 on terminal strip without protective housing and IP51 in protective housing, per IEC 60529
Mechanical environment	Class M1 per Measuring Instrument Directive (MID), (2004/22/EC)	Class M1 per Measuring Instrument Directive (MID), (2004/22/EC)	Class M1 per Measuring Instrument Directive (MID), (2004/22/EC)
Electromagnetic environment	Class E2 per Measuring Instrument Directive (MID), (2004/22/EC)	Class E2 per Measuring Instrument Directive (MID), (2004/22/EC)	Class E2 per Measuring Instrument Directive (MID), (2004/22/EC)

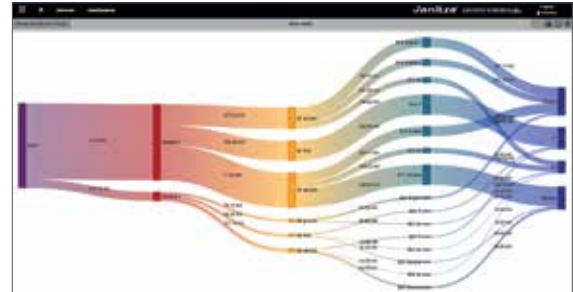
	B21 Single-phase energy meter	B23 Three-phase energy meter, direct measurement	B24 Three-phase energy meter, CT measurement
<b>Digital outputs</b>			
Current	2 – 100 mA	2 – 100 mA	2 – 100 mA
Voltage	24 V AC – 240 V AC, 24 V DC – 240 V DC. With meters with only 1 output, 5 – 40 V DC	24 V AC – 240 V AC, 24 V DC – 240 V DC. With meters with only 1 output, 5 – 40 V DC	24 V AC – 240 V AC, 24 V DC – 240 V DC. With meters with only 1 output, 5 – 40 V DC
Output pulse frequency	Programmable: 1 – 999999 pulse/kWh, pulse/MWh	Programmable: 1 – 999999 pulse/kWh, pulse/MWh	Programmable: 1 – 999999 pulse/kWh, pulse/MWh
Pulse length	10 – 990 ms	10 – 990 ms	10 – 990 ms
Connection cross-section	0,5 – 1 mm <sup>2</sup>	0,5 – 1 mm <sup>2</sup>	0,5 – 1 mm <sup>2</sup>
Recommended tightening torque	0.25 Nm	0.25 Nm	0.25 Nm
<b>Digital inputs</b>			
Voltage	0 – 240 V AC/DC	0 – 240 V AC/DC	0 – 240 V AC/DC
OFF	0 – 12 V AC/DC	0 – 12 V AC/DC	0 – 12 V AC/DC
ON	57 – 240 V AC/24 – 240 V DC	57 – 240 V AC/24 – 240 V DC	57 – 240 V AC/24 – 240 V DC
Min. pulse length	30 ms	30 ms	30 ms
Connection cross-section	0,5 – 1 mm <sup>2</sup>	0,5 – 1 mm <sup>2</sup>	0,5 – 1 mm <sup>2</sup>
Recommended tightening torque	0,25 Nm	0.25 Nm	0.25 Nm
<b>Electromagnetic compatibility</b>			
Surge voltage testing	6 kV 1,2/50 μs (IEC 60060-1)	6 kV 1,2/50 μs (IEC 60060-1)	6 kV 1,2/50 μs (IEC 60060-1)
Voltage swell testing	4 kV 1,2/50 μs (IEC 61000-4-5)	4 kV 1,2/50 μs (IEC 61000-4-5)	4 kV 1,2/50 μs (IEC 61000-4-5)
Cable-based transients	4 kV (IEC 61000-4-4)	4 kV (IEC 61000-4-4)	4 kV (IEC 61000-4-4)
Immunity from interference from electromagnetic HF fields	80 MHz – 2 GHz (IEC 61000-4-6)	80 MHz – 2 GHz (IEC 61000-4-6)	80 MHz – 2 GHz (IEC 61000-4-6)
Immunity from interference from conducted interference	150 kHz – 80 MHz (IEC 61000-4-6)	150 kHz – 80 MHz (IEC 61000-4-6)	150 kHz – 80 MHz (IEC 61000-4-6)
Immunity from interference with harmonics	2 kHz – 150 kHz	2 kHz – 150 kHz	2 kHz – 150 kHz
High frequency emissions	EN 55022, class B (CISPR22)	EN 55022, class B (CISPR22)	EN 55022, class B (CISPR22)
Electrostatic discharge	15 kV (IEC 61000-4-2)	15 kV (IEC 61000-4-2)	15 kV (IEC 61000-4-2)
Standards	IEC 62052-11, IEC 62053-21 class 1 & 2, IEC 62053-22 class 0,5S, IEC 62053-23 class 2, IEC 62054-21, GB/T 17215.211-2006, GB/T 17215.312-2008 class 1 & 2, GB/T 1725.322-2008 class 0.5S, GB 4208-2008, EN 50470-3 category A, B & C		
<b>Mechanical</b>			
Material	Polycarbonate in transparent front glass, top and bottom housing and terminal covering		
Dimensions	35 x 97 x 65 mm (W x H x D)	70 x 97 x 65 mm (W x H x D)	70 x 97 x 65 mm (W x H x D)
DIN modules	2	4	4

# Remote read-out with a higher-level PC





Tabular energy reports



Sankey diagrams



Dashboard Editor



**UMG 604-PRO**  
Power quality analyser

Modbus



**MID energy meters**  
1-phase or 3-phase



**ProData® data logger**  
Gateway for energy meter

Pulse inputs



**MID energy meters**  
1-phase or 3-phase



# ProData® DATA LOGGER

Ethernet



Modbus-Ethernet gateway



Memory 32 MB



Pulse inputs and  
Pulse outputs



Thermistor input



Threshold value monitoring

**Smart and compact:**

**Save energy costs through the universal data logger**

- Basis for a comprehensive energy management system (ISO 50001)
- Mapping of all consumption and process data (current, water, gas, steam, pressure, etc.)
- Monitoring of switching statuses (e.g. circuit breaker, etc.)
- Analysis of energy consumption and operating hours
- Flexible integration in superordinate systems (Modbus-Ethernet gateway)
- Long-term storage of data with 32 MB onboard memory
- Saving of 24 differential monthly energy values as well as maximum power values - for each of the fifteen individual inputs on board
- Direct reading out and analysis of data via GridVis® Power Grid Monitoring Software
- Free programming of 64 independent weekly timers
- Tariff conversion: Each digital input can be assigned a selected tariff from 1 to 8

**Universal data logger for all consumption media**

- 15 digital / pulse inputs
- 3 digital outputs, switchable via Modbus, weekly timer, threshold value and temperature monitoring
- Temperature measurement input
- Ethernet interface (ModbusTCP/IP, NTP ...)
- RS485 (Modbus RTU, slave, up to 115 kbps)
- 32 MB flash data memory
- Clock and battery function
- 64 weekly timers
- Threshold value monitoring
- Modbus-Ethernet gateway functionality
- Saving of minimum and maximum values (with time stamp)
- Configurable records, can be read out via RS485 and Ethernet

**Applications**

- EnMS per ISO 50001
- Integration of previously installed pulse counters in an EnMS
- Logging of non-electrical values
- Generation of performance indicators (key figures)
- Logging and monitoring of status messages
- Generation of alarms
- Ethernet-Modbus-Slave gateway

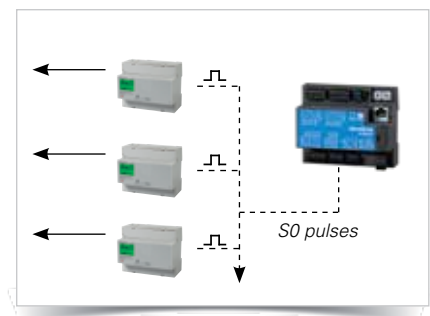


Fig.: Easy integration of existing meters



Fig.: Consolidation of diverse consumption media



### Ethernet with gateway functionality

- Communication via Ethernet and Modbus RS485
- Simple integration in the LAN network
- Rapid and reliable data transfer
- Access to measurement data via various channels

### Simple integration of existing meters

- Via Modbus-Ethernet Gateway integration and read-out of subordinate Modbus slave devices (e.g. electricity meters) possible with ease
- Conveniently capture measurements from all brands of meter with an S0 pulse output

### Well thought-out to the last (vital) detail

- Internal clock generates precise data and time information for records and events
- Permanent operation of the clock thanks to integrated emergency battery
- Battery not permanently installed; as such convenient replacement possible

### The ProData is the practical person's favourite

- Wide range power adapter (20 – 250 V AC, 20 – 300 V DC)
- Auto-Baud detection of the communication interface
- Screwable plug-in terminals
- Modbus address easily externally adjustable
- Rapid DIN rail installation

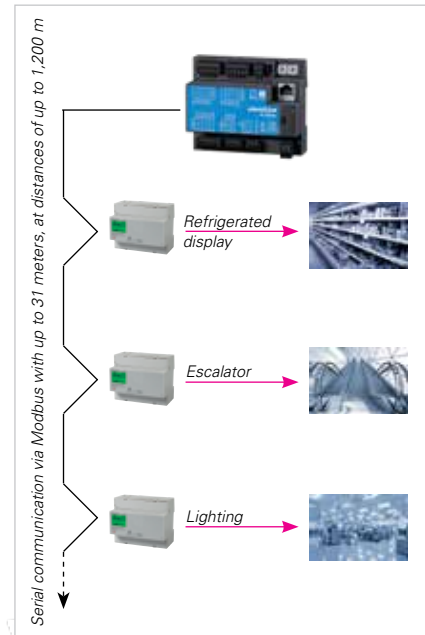


Fig.: Simple consolidation of Modbus meters

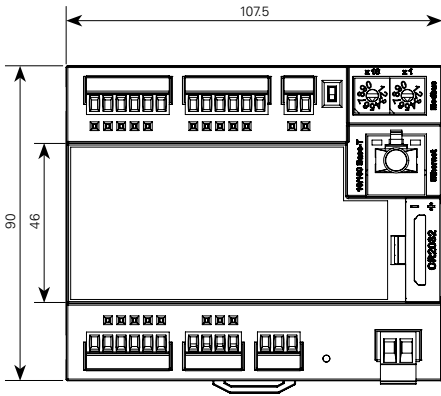


Fig.: Easy exchange of the battery during operation

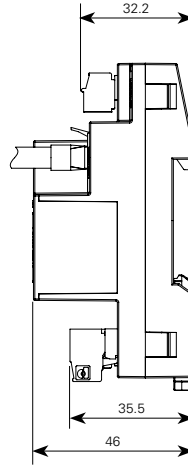


## Dimension diagrams

All dimensions in mm



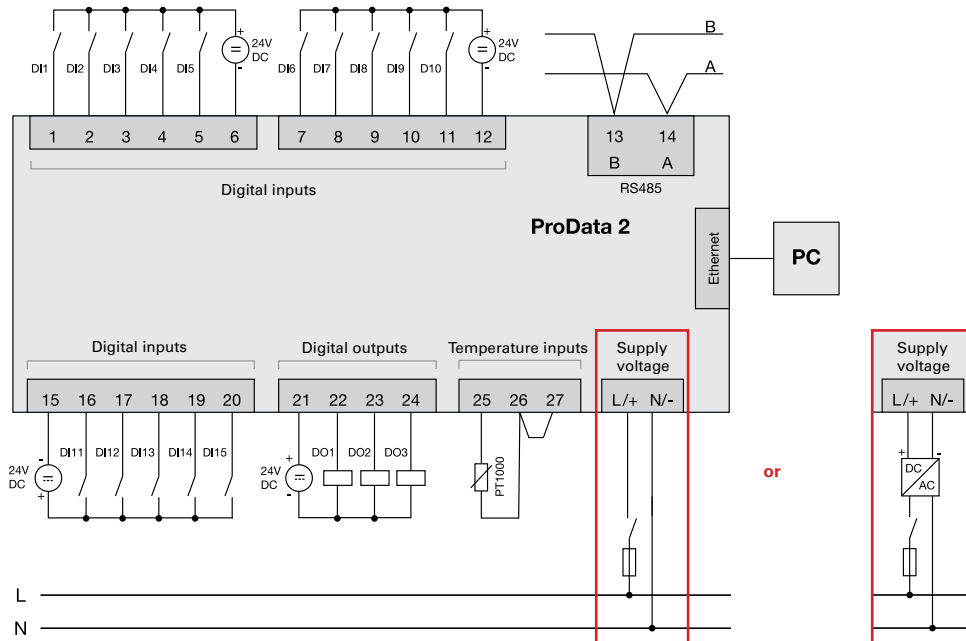
Front view



Side view



## Typical connection



Connection example via an external power supply



## Device overview and technical data

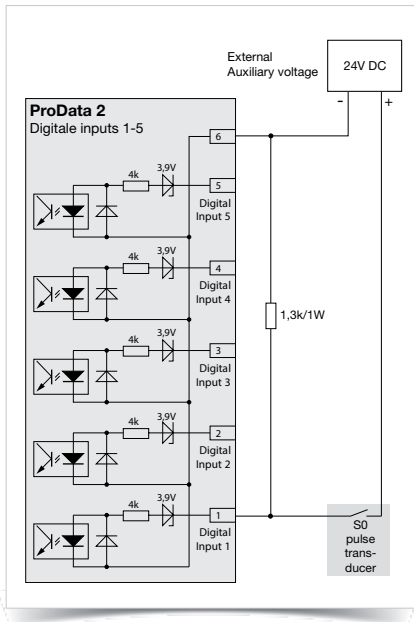


Fig.: S0 pulse input with external supply voltage and external plug-in resistor module\*<sup>3</sup>

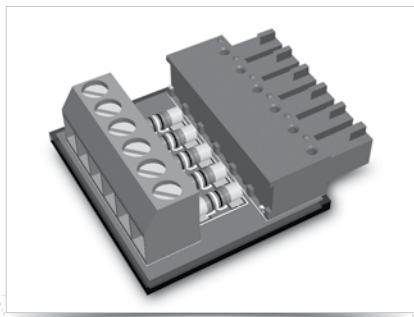


Fig.: S0 plug-in module (item no.: 52.24.111)

Comment: For detailed technical information please refer to the operation manual and the Modbus address list.

• = included - = not included

\*1 Use as a Modbus RTU slave is not possible in this mode. The ProData is only able to pass on requests to a Modbus slave device; it cannot request Modbus slave devices itself.

\*2 Additional functions can be purchased with the GridVis® Standard or Expert editions.

\*3 External resistor S0 plug-in module for connection to an S0 pulse transducer required (item no.: 52.24.111)

ProData	
Item number	52.24.011
Supply voltage	20 – 250 V AC or 20 – 300 V DC
Overvoltage category	300 V CAT II
Power consumption	max. 4 VA / 2 W

General	
Use in low voltage networks	•
Other measurements	
Operating hours measurement	•
Clock	•
Data logging	
Memory (Flash)	32 MB
Mean, minimum, maximum values	•
Alarm messages	•
Threshold value monitoring	•
Time stamp	•
Inputs / outputs	
Digital inputs	15
Digital outputs (as switch or pulse output)	3
Temperature measurement input	1
Password protection	•
Communication	
Interfaces	
RS485: 9.6 – 115.2 kbps	•
Ethernet 10/100 Base-TX (RJ-45 socket)	•
Protocols	
Modbus RTU, Modbus TCP	•
Modbus Gateway for Master-Slave configuration* <sup>1</sup>	•
NTP (time synchronisation)	•
DHCP	•
TCP/IP	•
ICMP (Ping)	•
Power Grid Monitoring Software GridVis® Essentials* <sup>2</sup>	
Device configuration	•
Graph function	•
Device overview	•
Event browser	•
Basic data exports	•
RCM data exports	•

Technical data	
Digital inputs and outputs	
Number of digital inputs	15
Supply voltage	20 – 30 V DC (SELV or PELV supply)
Pulse output (S0), maximum count frequency	25 Hz
Input signal present	> 18 V DC (typical 4 mA for 24 V)
Input signal not present	0 ... 5 V DC
Number of digital outputs	3
Supply voltage	20 – 30 V DC (SELV or PELV supply)
Switching voltage	max. 60 V DC
Switching current	max. 50 mAeff DC
Pulse output (energy pulse)	max. 20 Hz
Maximum line length	up to 30 m unscreened, from 30 m screened
Temperature measurement input	1
Update time	1 sec.
Suitable temperature sensor	PT100, PT1000, KTY83, KTY84
Total burden (sensor and cable)	max. 4 kOhm

## Chapter 03

### ProData® data logger

Mechanical properties and others	
Weight	200 g
Device dimensions in mm (W x H x D)	107.5 x 90 x approx. 46
Battery	Lithium battery CR2032, 3 V (approval i.a.w. UL 1642)
Protection class per EN 60529	IP20
Assembly per IEC EN 60999-1 / DIN EN 50022	DIN rail mounting
Connection capacity of the terminals (digital inputs / outputs, temperature thermistor inputs) rigid / flexible	0.2 to 1.5 mm <sup>2</sup>
Flexible with core end sheath without plastic sleeve	0.2 to 1.5 mm <sup>2</sup>
Flexible with core end sheath with plastic sleeve	0.2 to 1.5 mm <sup>2</sup>
Terminal connection capacity	
Serial interface	
Single core, multi-core, fine-stranded terminal pins, core end sheath	0.2 to 1.5 mm <sup>2</sup> 0.2 to 1.5 mm <sup>2</sup>
Environmental conditions	
Temperature range	Operation: K55 (-40 ... +70 °C)
Relative humidity	Operation: 0 to 95 % RH
Operating altitude	0 ... 2,000 m above sea level
Pollution degree	2
Mounting position	any
Electromagnetic compatibility	
Electromagnetic compatibility of operating equipment	Directive 2004/108/EC
Electrical appliances for application within particular voltage limits	Directive 2006/95/EC
Equipment safety	
Safety requirements for electrical equipment for measurement, regulation, control and laboratory use – Part 1: General requirements	IEC/EN 61010-1
Particular requirements for Test and measurement current circuits	IEC/EN 61010-2-030
Noise immunity	
Class A: Industrial environment	IEC/EN 61326-1
Electrostatic discharge	IEC/EN 61000-4-2
Electromagnetic fields 80 – 1000 MHz	IEC/EN 61000-4-3, EMV-ILA V01-03
Electromagnetic fields 1000 – 2700 MHz	IEC/EN 61000-4-3, EMV-ILA V01-03
Rapid transients	IEC/EN 61000-4-4, EMV-ILA V01-03
Surge voltages	IEC/EN 61000-4-5, EMV-ILA V01-03
HF conducted interferences 0.15 – 80 MHz	IEC/EN 61000-4-6, EMV-ILA V01-03
Voltage dips, short term interruptions, voltage variations and frequency change	IEC/EN 61000-4-11, EMV-ILA V01-03
Emissions	
Class B: Residential environment	IEC/EN 61326-1
RFI Field Strength 30 – 1000 MHz	IEC/CISPR11/EN 55011
Radiated interference voltage 0.15 – 30 MHz	IEC/CISPR11/EN 55011
Radiated interference voltage 9 – 150 MHz	EMV-ILA V01-03
Safety	
Europe	CE labelling
USA and Canada	UL labelling
Firmware	
Firmware update	Please observe the operating instructions

Comment: For detailed technical information please refer to the operation manual and the Modbus address list.

• = included - = not included

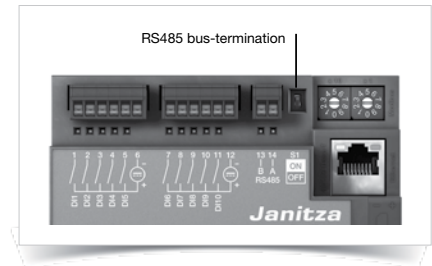
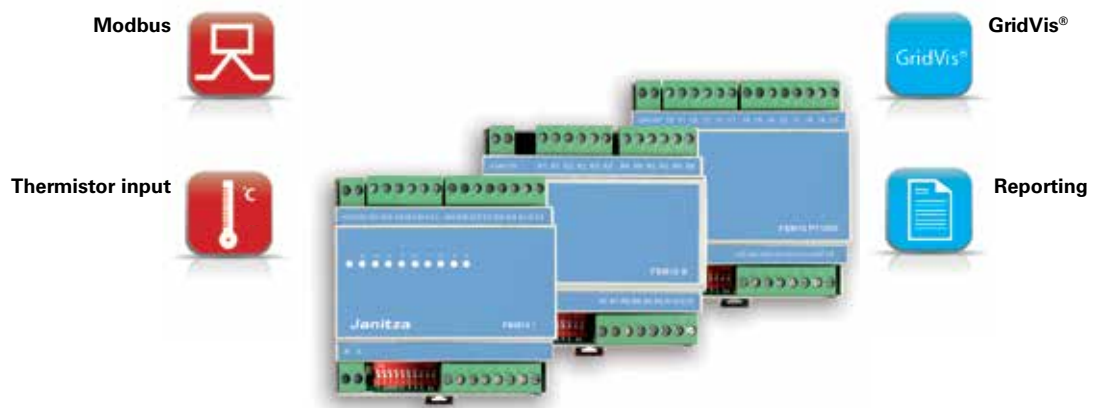


Fig.: Modbus / RS485 termination

# FIELD BUS MODULES SERIES FBM



## Chapter 03

### Field bus modules series FBM

#### Decentralised I/O field bus module series FBM10

- RS485 interface
- Protocol Modbus RTU
- Can be used as a slave device to the measurement devices from series UMG 604-PRO, UMG 605-PRO, UMG 509-PRO and UMG 512-PRO
- Also possible to connect over a distance of 1,000 m to the RS485 Modbus Master interface of the device; either via Profibus cable or e.g. a cable of type Li2YCY(TP) 2 x 2 x 0.22
- Modules are available pre-configured and programmed according to the selected measurement device

#### Use of the modules FBM10I and FBM10R

- Consolidation of various input and output signals in order to distribute to the respective participants
- Connection with the respective Modbus master from the device series UMG 604-PRO, UMG 605-PRO, UMG 509-PRO or UMG 512-PRO is required in order to use the field bus modules.
- All data points are integrated into the Janitza system
- Detection of a wide range of key variables such as process data, states, error messages, threshold values, alarm outputs, etc.
- Archiving and visualisation via the Power Grid Monitoring Software GridVis®

#### Example of using the inputs

- Tariff conversion
- Synchronising measurement periods
- Error messages
- State measurements

#### Example of using the outputs

- Threshold value outputs for measured values

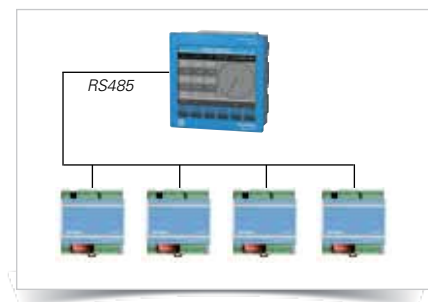
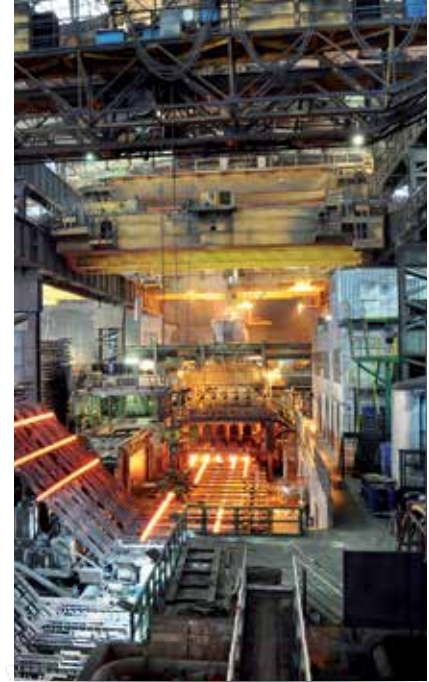


Fig.: Connection of the I/O field bus modules takes place via the RS485 interface of the UMG measurement device

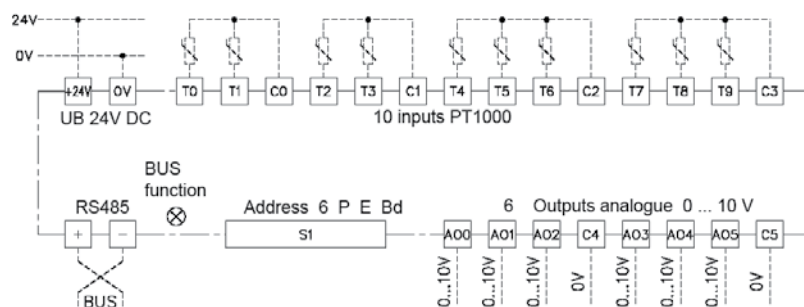


Fig.: Connection diagram FBM10 PT1000/PT100; thermistor input 2-wire

### Use of the FBM10PT1000 module

- Temperature field bus module
- Logging of up to 10 temperature measurements (e.g. via PT100 or PT1000)
- The recording and visualisation of the measured values takes place with the aid of UMG 604-PRO, UMG 605-PRO, UMG 509-PRO or UMG 512-PRO and the required expansion (see chapter 04 APPs – Expansion with know-how)



Fig.: Following the APP installation it is also possible to save the values.

### Example

- Temperature monitoring
- Temperature logging

Field bus modules series FBM					
Type	Relay outputs	Digital inputs* <sup>1</sup>	Analogue inputs* <sup>2</sup>	Thermistor inputs	Item no.
FBM10I* <sup>3</sup>	–	10	–	–	15.06.076
FBM10PT1000* <sup>3</sup>	–	–	–	10	15.06.077
FBM10R-NC* <sup>3</sup>	10	–	–	–	15.06.078
FBM DI8-AI8* <sup>3</sup>	–	8	8	–	15.06.079

\*<sup>1</sup> Only state message

\*<sup>2</sup> 4 – 20 mA

\*<sup>3</sup> The modules are not suitable for the ProData in gateway operation.

General technical data	
Supply voltage	24 V DC ±20 %
No-load current	20 mA
Interface, protocol	RS485, Modbus-RTU
Transmission rate	4,800 to 38,400 Bit/s
Digital input	24 V DC, 5 mA
Relay outputs	24 V DC 0.5 A / 250 V / 3 A AC1 / 2 A AC3
Ambient temperature	-10 ... +50 °C
Accuracy	<0.1 % for temperature measurement PT1000
EMC	per EN 55011
Terminal	plug-in terminals up to 1 mm <sup>2</sup>
Housing	45 mm installation row system 88 x 90 x 58 mm (W x H x D)
Installation	top-hat rail
Humidity	<95 % rel. humidity non-condensing
Protection class	IP20
Standards	CE conformity

# 04 Software and IT solutions

<b>Janitza software and IT solutions</b>	<b>Page 185</b>
<ul style="list-style-type: none"><li>• UMG device homepage &amp; APPs</li><li>• GridVis® Power Grid Monitoring Software</li></ul>	
<b>Power Grid Monitoring Software – GridVis®</b>	<b>Page 187</b>
<ul style="list-style-type: none"><li>• Software for energy and power quality monitoring systems</li><li>• Management of all measurement data, general electrical parameter / energy / power quality / RCM</li><li>• Programming and configuration of the measurement devices</li></ul>	
<b>GridVis® Collector</b>	<b>Page 199</b>
<ul style="list-style-type: none"><li>• Mobile unit for read out measurement data from Janitza measurement devices without a communication connection</li><li>• Battery runtime of up to 9 hours</li><li>• Manage up to 500 measuring devices</li></ul>	
<b>Jasic® programming language (PLC functionality)</b>	<b>Page 201</b>
<ul style="list-style-type: none"><li>• Special programming / script language for various different UMG measurement devices</li><li>• Functions in the UMG device can be individually expanded</li><li>• Up to 7 user defined programs possible</li></ul>	
<b>APPs – expansions with know-how</b>	<b>Page 205</b>
<ul style="list-style-type: none"><li>• Expansions (APPs) for various different UMG measurement devices</li><li>• Functions integrated in the UMG device can be expanded, controlled and visualised via APPs</li><li>• Administration and installation via GridVis® Power Grid Monitoring Software</li></ul>	
<b>Device homepage</b>	<b>Page 216</b>
<ul style="list-style-type: none"><li>• Power management and power quality analysis online</li><li>• Software installation not required</li><li>• Online data, historical data, graphs recording events and much more are directly available from the device homepage</li></ul>	
<b>Multi Protocol Server (OPC UA)</b>	<b>Page 217</b>
<ul style="list-style-type: none"><li>• Increase the connectivity of the GridVis®</li><li>• Exchange all kinds of measuring values, KPIs and any kind of process parameters via OPC UA ITEMS (Tags)</li><li>• In addition to the direct GridVis® connection, the Multi Protocol Server also offers KNX, SNMP as well as BACnet clients</li></ul>	
<b>Complete server with GridVis® Power Grid Monitoring Software and database</b>	<b>Page 219</b>
<ul style="list-style-type: none"><li>• Powerful server as complete solution</li><li>• Pre-configured server guarantees immediate usability</li><li>• Simple integration into existing network</li></ul>	





# JANITZA SOFTWARE AND IT SOLUTIONS





# GridVis® – Power Grid Monitoring Software



# Three applications – one software package

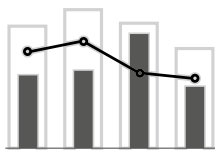


## Energy management – Power quality – Residual current monitoring

Implement all three application areas of energy management, power quality and residual current monitoring with the scalable GridVis® network analysis software. GridVis® identifies energy saving potentials and helps to optimize the utilization of operating equipment as well as detect production downtimes at an early stage. Numerous functions support the fulfillment of standards, the preparation of key figures and the analysis of measured values. This makes the scalable, user-friendly software perfectly suited for developing standards-compliant energy, residual-current and power-quality monitoring systems, and it has been classified by the BAFA as energy management software that is eligible for funding. Depending on your requirements, three editions with different functionalities are available.

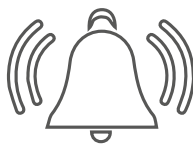


### ENERGY MANAGEMENT



Certified according to ISO 50001. With Janitza GridVis®, you are on the safe side when it comes to things like BAFA, reduction of the EEG levy or peak balancing according to SpaEfV.

### SAFETY & ALARM MANAGEMENT



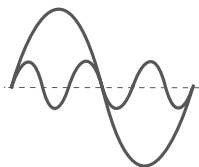
Monitor limit values of measured variables, consumption data, residual currents and device communication. Escalation levels for needs-based alerting via email and web interface.

### VISUALIZATION & DOCUMENTATION



Visualization according to your needs. Create dashboards quickly and easily without programming knowledge and use the report editor for custom-designed reports.

### NETWORK ANALYSIS & EVALUATION



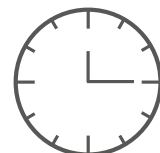
Analyze and evaluate measurement data. Use numerous tools such as statistics, charts, heatmaps, Sankey diagrams and key performance indicators.

### CONNECTIVITY

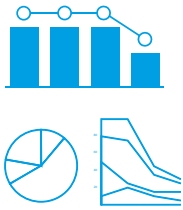


Whether OPC UA, REST API or CSV. We offer many options for data import & export as well as data access. An open and future-proof system.

### AUTOMATION



Automation functions for time-controlled task management. Plan data imports, report generation or device readouts and create shift schedules.

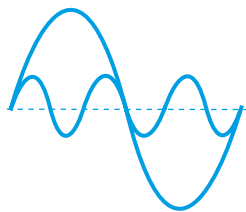


- FREE LAYOUT DESIGN
- APPLICATION-ORIENTED FUNCTIONS

## Visualization

Create your own overviews with numerous functions and graphics

- Professional editor for creating dashboards
- Dashboards and templates: free design of overviews
- User management and access right control
- Large number of widgets and functions:  
Line, bar and pie charts, heat map, Sankey, key performance indicators (KPI), tables, indicators, duration line, weather, live values, links and much more.



- PROFESSIONAL TOOLS FOR EVALUATING ALL MEASUREMENT AND CONSUMPTION DATA

## Analysis & Evaluation

All details at one glance, with our tools for analyzing and evaluating your measurement data

- Event browser
- Graph and graph set functions
- Statistical evaluations
- CBEMA curve
- Duration curve
- Dashboards & widgets
- RCM analysis



Fig.: GridVis® Event browser

## Documentation

### Reports optimized for EnMS, power quality and RCM

- EN 50160 & EN 61000-2-4 evaluation
- Uptime analysis as well as statistical analyses
- Events, transients and limit violation
- Energy overviews
- Energy invoice
- Residual current analysis
- System acceptance
- Utilization report
- Report editor

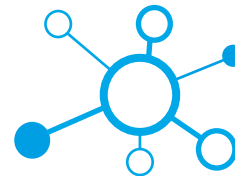


- XLS- UND PDF-OUTPUT
- AUTOMATIC E-MAIL SENDING

## Connectivity

### Data access, data export and import made easy

- OPC UA client and server (optional)
- REST API (M2M solution)
- External Modbus devices
- CSV, XLS import & export
- GridVis® Collector (mobile data collector)
- MSCONS (load profile, counter data, import and export)
- COMTRADE (transients, events, export)



- FUTURE-PROOF SOLUTIONS
- OPEN SYSTEM
- THE LATEST TECHNOLOGIES

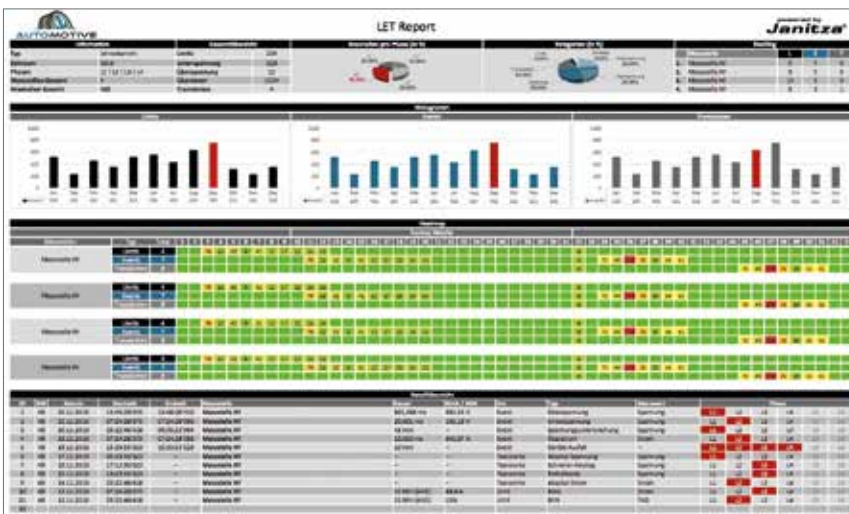


Fig.: GridVis® LET report

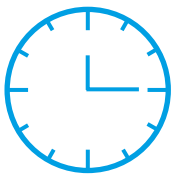


- UPTIME
- RELIABILITY AND SAFETY THROUGH MONITORING
- MEASUREMENT TECHNOLOGY AND MEASURED VALUES UNDER CONTROL

## Alerting

### System and energy monitoring at the highest level

- Monitoring communication, limit values, etc.
- Alerts via web UI, e-mail or external program
- Confirmation obligation with logging & history
- Escalation stages for demand-based alerting
- Full access to measurement data and communication parameters

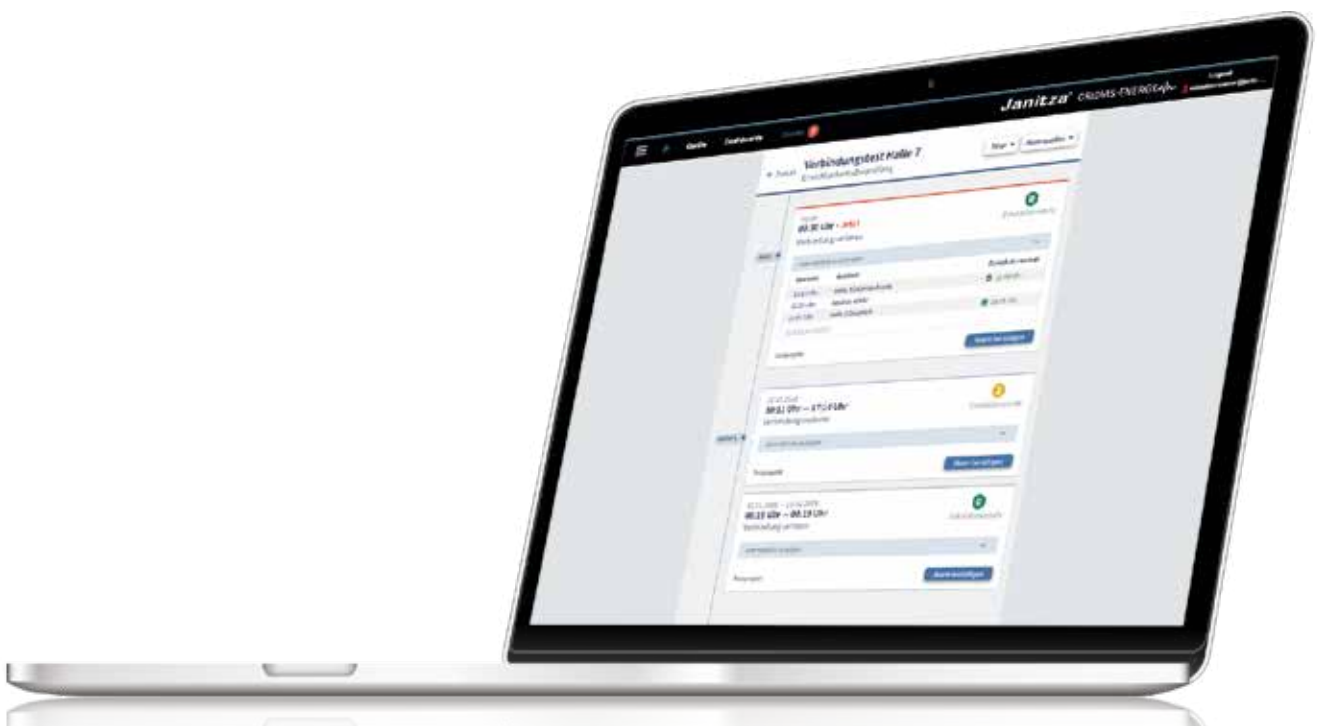


- TIME TASK MANAGEMENT
- EASY SYSTEM HANDLING THROUGH AUTOMATION FUNCTIONS

## Automation

### Planning functions and automating your system

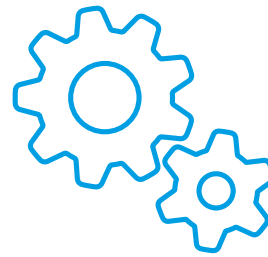
- Plan device readouts, time synchronization, report generation or e-mail dispatch
- Automatic data import
- Database management with automation functions
- Shift schedules and tariffs
- Project backup





## Web interface

- Dashboards and widgets
- No local installation required



## Engineering Tool

- Local installation
- Commissioning and parameterization of measuring devices
- Analysis and evaluation

## Database

- Jan DB (database in the scope of delivery)
- MySQL (driver) ■ MSSQL (driver)

## Service

- Background process
- Operable without registered users

## User administration & language

- Password protection and access control
- Active Directory
- User management
- German, English, Spanish

## Virtual measurement points & logic

- Measurement points without measuring device
- Mathematic operations

## Data recording & device configuration

- Memory readout
- Online recorder
- Device parameterization

## GridVis® Editions – The ideal range of functions for every requirement

There are three GridVis® Editions available. The free GridVis® Essentials covers basic functions for configuration, visualization and documentation. GridVis® Standard adds numerous options for visualizing data and a web interface which can be used to create dashboards, for example. Various system functions and data exports facilitate data management and enable adaptation to the respective requirements. GridVis® Expert provides the full range of GridVis® functions. A detailed overview of the functions and differences can be found in the following table.

	GridVis® Essentials	GridVis® Standard	GridVis® Expert
<b>SYSTEM FUNCTIONS</b>			
Device configuration	•	•	•
Service	–	•	•
Logic	–	•	•
Automation	–	•	•
Online recorder	–	•	•
Database management	–	•	•
Device monitoring	–	•	•
User management	–	•	•
Active directory	–	–	•
Alarm management	–	–	•
<b>VISUALIZATION</b>			
Graph function	•	•	•
Device overview	•	•	•
Event browser	•	•	•
Dashboards & templates	–	•	•
Widget basic package	–	•	•
Widget enhancement	–	–	•
Sankey diagram	–	–	•
Key performance indicators (KPI)	–	–	•
<b>DOCUMENTATION</b>			
Basic data exports	•	•	•
RCM data exports	•	•	•
PQ data exports	–	•	•
EnMS data exports	–	•	•
Report editor	–	–	•
<b>CONNECTIVITY</b>			
CSV data import	–	•	•
MSCONS data import	–	•	•
REST API	–	•	•
Modbus devices from third party suppliers	–	–	•
OPC UA Client	–	–	•
Comtrade data exports	–	–	•
MSCONS data export	–	–	•

Further information about the GridVis® Editions can be found here: <https://www.gridvis.com/gridvis-editions.html>



The fee-based Standard and Expert Editions can be ordered using the following part numbers

Designation	GridVis® Standard	GridVis® Expert
<b>Basic packages</b>		
Quantity of items	Part no.:	Part no.:
10 items	51.00.601	51.00.701
25 items	51.00.602	51.00.702
50 items	51.00.603	51.00.703
100 items	51.00.604	51.00.704
> 100 items	on request	on request
<b>Add items</b>		
Quantity of items	Part no.:	Part no.:
10 more items	51.00.621	51.00.721
25 more items	51.00.622	51.00.722
50 more items	51.00.623	51.00.723
<b>Extend update period*</b>		
Quantity of items	Part no.:	Part no.:
10 items for 1 year	51.00.641	51.00.741
25 items for 1 year	51.00.642	51.00.742
50 items for 1 year	51.00.643	51.00.743
100 items for 1 year	51.00.644	51.00.744
> 100 items for 1 year	on request	on request
10 items for 3 years	51.00.661	51.00.761
25 items for 3 years	51.00.662	51.00.762
50 items for 3 years	51.00.663	51.00.763
100 items for 3 years	51.00.664	51.00.764
> 100 items for 3 years	on request	on request
<b>Upgrade to the Expert Edition</b>		
Quantity of items	Part no.:	
10 items	51.00.681	
25 items	51.00.682	
50 items	51.00.683	
100 items	51.00.684	
> 100 items	on request	

\* The update period will be charged against the existing license update period and the total number of items and credited to the license.

## Edition Essentials

### Free entry-level model

GridVis® Essentials offers basic functions for the configuration of devices and a graph function for the visualization of current and historical measured values. In addition, a tool for evaluating events and transients is included. Simple standard reports, such as the EN 50160 evaluation or CSV/XLS data exports as well as reports for residual current measurement (RCM) are provided.

### GridVis® Essentials range of functions:

#### Device configuration

- Setting and parametrization options for Janitza products

#### Graph function

- For online and historical values

#### Device overview

- Overview of measurement devices with search and filter function

#### Event browser

- Tool for easy evaluation of events and transients

#### Basic data exports

- Commissioning report
- EN 50160 evaluation
- CSV exports
- Energy report

#### RCM data exports

- For clear and uncomplicated display of measurement data from residual current measurements



## Edition Standard

### Additional functions and visualization options

In addition to the basic functions, GridVis® Standard has numerous options for visualizing data. Extensive system functions facilitate data management, create a quick overview and simplify processes. Data exports in the form of various reports facilitate evaluation. The data import function enables the import of external data such as turnover or quantities into GridVis®.

### Same range of functions as GridVis® Essentials, plus:

#### Service

- Background process that can be operated without a logged-in user (server)

#### Logic

- Logical links and operations (e.g. to create virtual measurement points, cost centers etc.)

#### Automation

- Readout of measurement memory, time synchronization, time and tariff management, automatic data export and email dispatch

#### Database management

- Database actions (e.g. database setup, device replacement, data compacting, backup creation, data deletion)
- MSSQL and MySQL drivers

#### Device monitoring

- Automatic notification in case of faulty device communication

#### User management

- Administration of users and their rights and roles

#### Dashboards & templates

- Visualization of measurement data on self-created web pages (dashboards)

#### Widget basic package

- Visual functions that can be placed on dashboards (line chart, pie chart, bar chart, live values)

#### REST API

- Interface for developers and application engineers to access historical and live values

#### Online recorder

- Recording of measurement data (e.g. for third-party devices, devices without memory or OPC UA connections)

#### PQ data exports

- High availability report
- LET report
- EN 50160 Annual evaluation

#### EnMS data exports

- Utilization report
- Energy bill
- Meter reading cycle report

#### CSV data import

- Data import of CSV files

#### MSCONS data import

- Data import of MSCONS files



## Edition Expert

### Enhanced range of functions based on GridVis® Standard

GridVis® Expert provides the full range of GridVis® functions. This includes additional visualization options, system functions and optimal adaptation to your needs. You can create key performance indicators as well as quantity flow diagrams and display them clearly. Your data can be imported securely and easily with the OPC UA Client. In addition, third-party devices can be integrated via Modbus/TCP or Modbus/RTU. Various protocols and interfaces are supported by the software. This means GridVis® Expert enables optimal processing of your data.

### Same range of functions as GridVis® Standard, plus:

#### Active Directory

- Connection to a central Windows user management via LDAP protocol

#### Alarm management

- Monitoring of energy consumption, measurement data, communication, and much more
- Alerting via email & website
- Logbook and escalation levels included

#### Widget enhancement

- Visual functions that can be placed on dashboards (heatmap, Sankey diagram, key performance indicators, weather)

#### Sankey diagram

- Creation of quantity flow diagrams (Sankey)
- Visual representation of energy consumption, historical and live

#### Key performance indicators (KPI)

- Creation and evaluation of key performance indicators
- Recognition of changes or improvements in the energetic baseline (EnB)

#### Modbus devices from third party suppliers

- Integration of third-party devices via Modbus/TCP or Modbus/RTU (RS-485)

#### Report editor

- Create and design individual reports

#### OPC UA Client

- Integration of OPC UA servers to access further measurement data, production figures or economic figures

#### Comtrade data exports

- Events and transients can be stored in the Comtrade format

#### MSCONS data export

- Consumption data can be stored in the MSCONS format



## GridVis® Collector – mobile data readout

As a mobile unit, the GridVis® Collector makes it possible to read out measurement data from Janitza measurement devices on site without a communication connection. This data can be compared and evaluated in a project with other measurement points. With a battery runtime of up to 9 hours, the GridVis® Collector can manage up to 500 measuring devices. The handling is easy to understand and can be done by a qualified electrician in just a few easy steps.

The synchronization of measurement data with a locally installed GridVis® can be done via Ethernet or WLAN.

The GridVis® Collector offers the ideal solution for collecting measurement data in local network stations or other autonomous electrical distribution systems, which do not have a wireless or network connection.



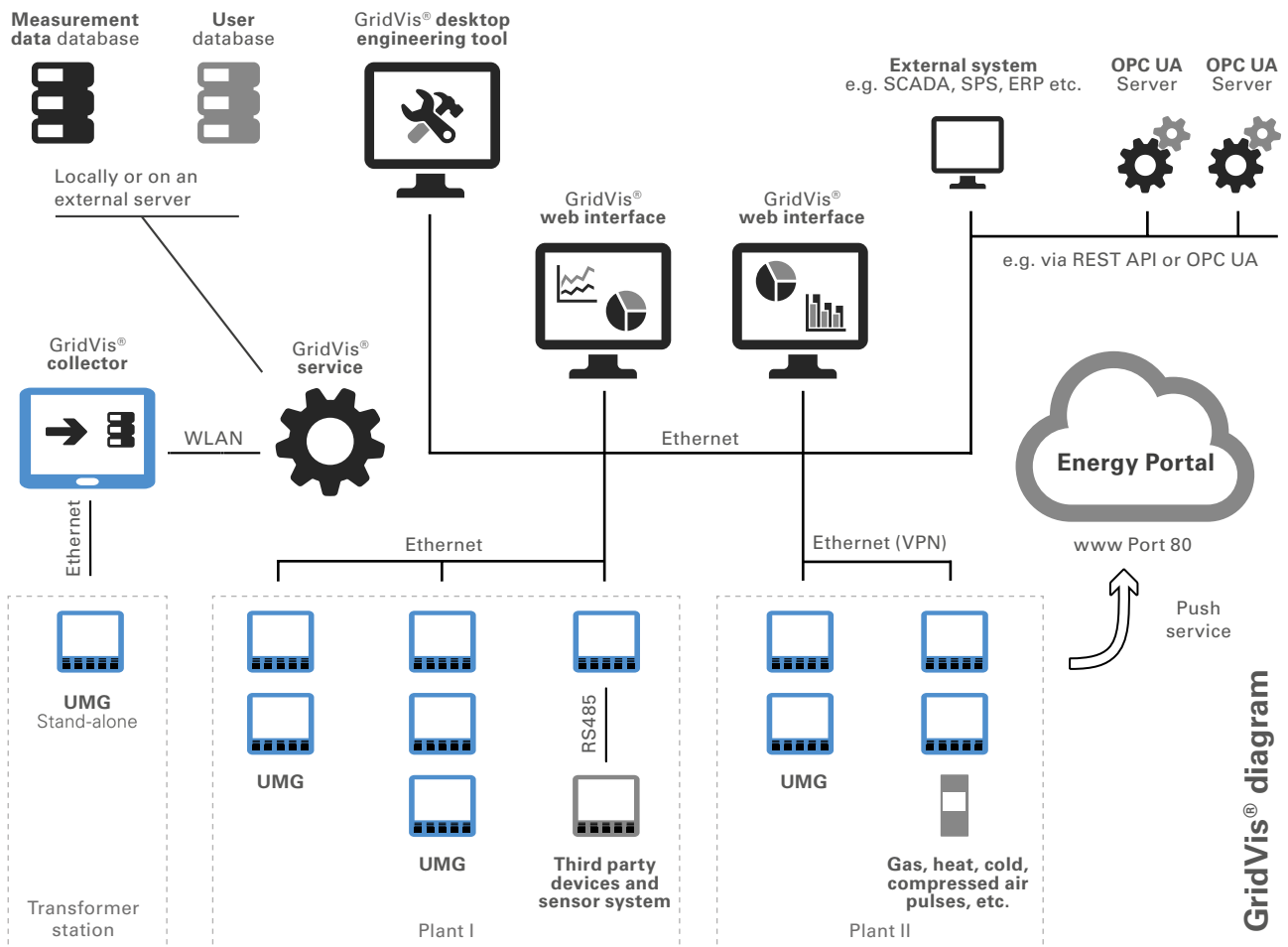
**GridVis® Collector**  
Item no. 51.00.400

The GridVis® Collector is not part of a GridVis® edition and can be purchased as an option.

## Services

Benefit from custom in-house training workshops and seminars and a diverse range of training courses at our training center in Lahnau. Professional consultation and support services are free for GridVis® customers. We will provide you with on-site assistance during your commissioning and offer fair maintenance contracts to ensure optimal system availability. Customized adjustments to reports are possible.

You can rely on a partner with an extensive product portfolio and many years of experience. As a partner with experience and know-how in numerous industries, we can help you to integrate a perfect solution in your company.



GridVis® diagram





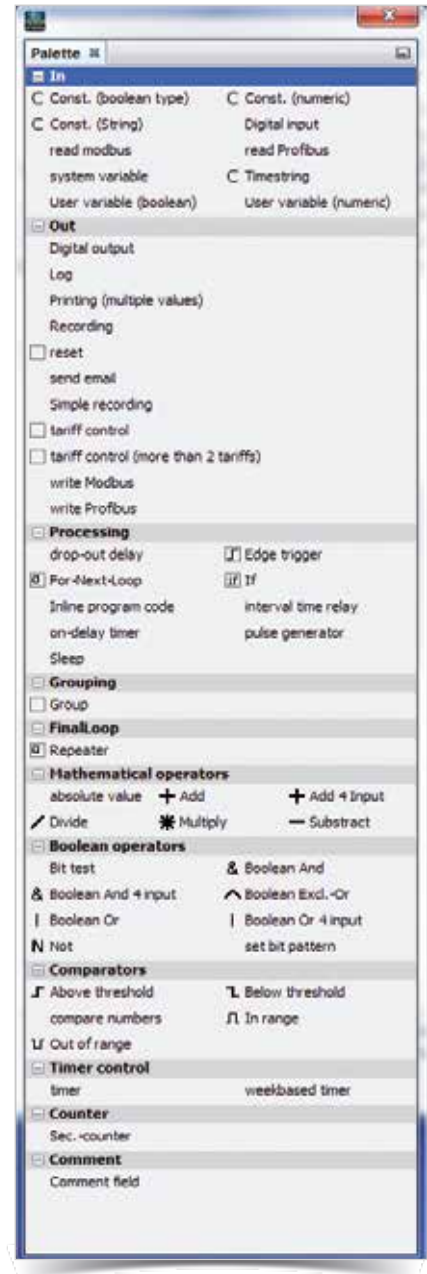
# Manifold programming options

- Special programming / script language for the measurement devices UMG 604-PRO / UMG 605-PRO / UMG 509-PRO and UMG 512-PRO
- The user is no longer restricted to the functionalities integrated in the measurement device, but rather the device can be expanded to suit the individual's requirements
- Graphical programming supports the creation and configuration of mathematical functions and logical links
- The devices' own digital outputs can be set
- Digital inputs can be easily evaluated
- The processing and writing of registers belonging to external devices can be implemented via the Modbus
- Free configuration of threshold value infringements, timer functions or recording of special values can be implemented
- Programs created can be stored as files or transferred directly to the measurement device
- There are 7 memory spaces available, each with 128 kByte, for the saving of the programs
- Simultaneous operation of these 7 programs possible
- User-friendly, graphical programming
- Free programming of the Jasic® source code by the user

```

1 SEN Storage für selected View, 0/View,1/F BT,2F BT, 3 G
2 SEN Low Word = View A
3 SEN High Word = View B
4 global (INT, _sel_selectedView,1,0,"")
5 SEN Same Selection Category
6 global (FLOAT, _sel_category,0,0,"")
7 SEN Storage für price für effective energy BT
8 global (FLOAT, _sel_effEnergy_M,0,0,"Cost/kWh")
9 SEN Storage für price für effective energy BT
10 global (FLOAT, _sel_effEnergy_Mt,0,0,"Cost/kWh")
11 SEN Storage für price für reactive energy
12 global (FLOAT, _sel_reactiveEnergy_M,0,0,"Cost/kWh")
13 SEN Makes LC device displayed and printed.
14 global (FLOAT, _sel_madePrintes,0,0,"")
15 SEN In-Box reset
16 global (FLOAT, _sel_reset(0...30),0,0,"")
17 SEN Bus devices, can't be changed after device starts.
18 global (INT, _sel_ModbusDev,1,0,"")
19 SEN Da den Benutzer über Fehler bei Zeit der zu informieren
20 global (INT, _sel_time_err_text,0,0,"")
21 SEN Deamonmod
22 global (INT, _sel_DeamonMod,0,0,"")
23 SEN Mittelwertzeit Zeit für Abgleichung des UMS103 Messwerte 2k = 40960
24 global (FLOAT, _sel_MW_4096,0,0,"")
25 SEN Makes ID IDG installed
26 global (FLOAT, _sel_IDG_installed,1,0,0,"")
    
```

Fig.: Jasic® source code

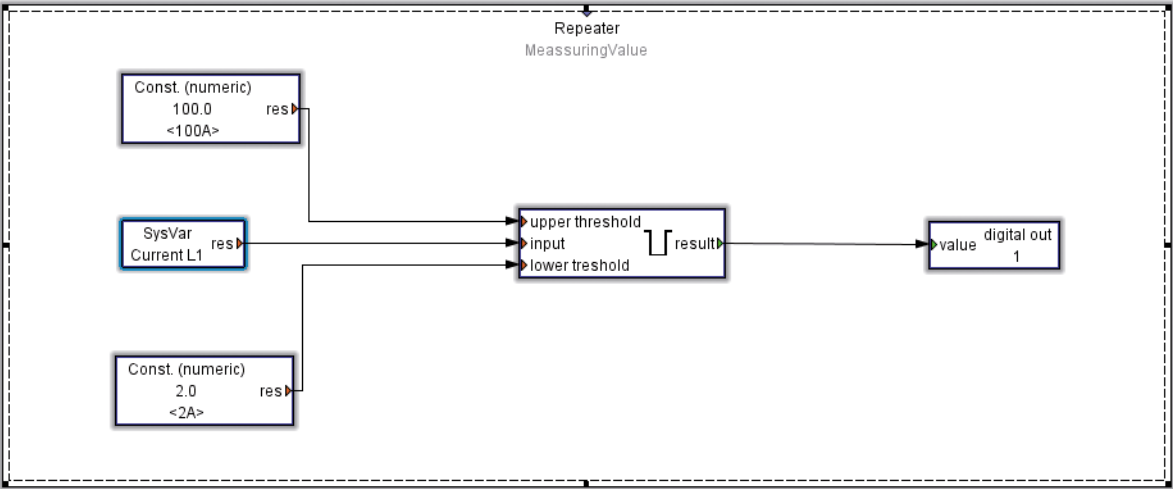


# Graphical programming: Examples

## Example of threshold value monitoring (comparator)

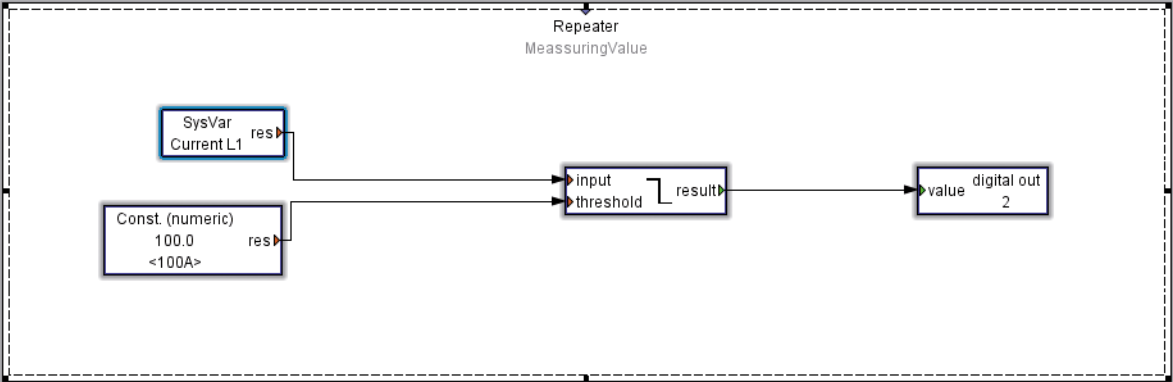
### Example 1

- Monitoring of current L1: Determination of the threshold value by means of constants, lower level 2 A, upper level 100 A
- Digital output 1 signals the exceedance of the predefined values



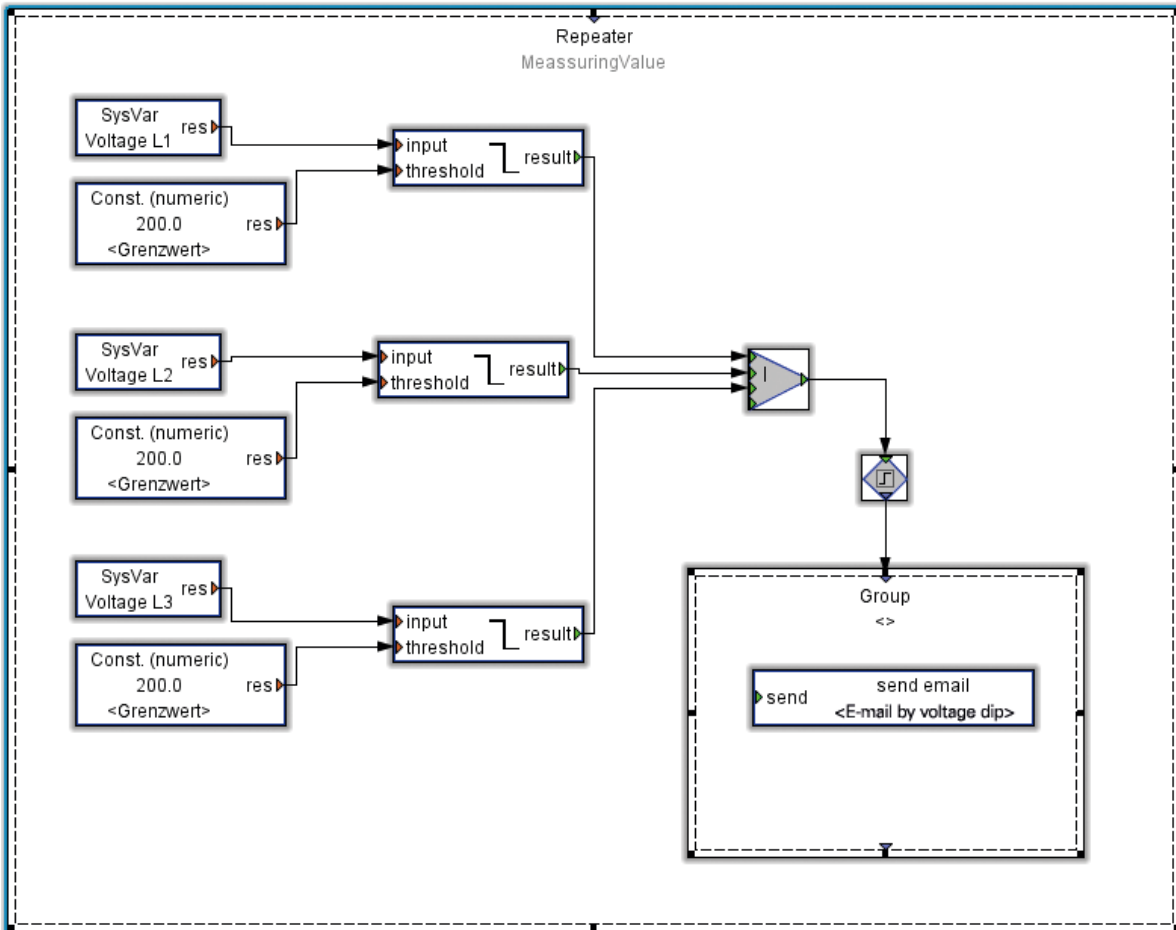
### Example 2

- Works with only one lower threshold (in this case 100 A)
- In the event of the current dropping below 100 A, digital output 2 will be activated



Example 3

- An email will be sent in the event of the value dropping below the predefined setting
- In this example the email will be sent with an under-voltage of < 200 V in phases L1, L2 or L3
- Additional information: Voltage values from the 3 phases at the time of the undervoltage



# APPs – expansions with know-how



## Software based expansions for the measurement devices

- Functions integrated in the UMG device can be expanded, controlled and visualised via APPs
- Depending on the application, consisting of several Jasic®, Flash and homepage files (administration and installation implemented via GridVis® Power Grid Monitoring Software)
- The programming language for creating APPs is Jasic®
- Alternatively, the programming can also be implemented graphically with the GridVis®
- Development of further APPs for the measurement devices by the user and third parties possible
- The creation of APPs requires programming knowledge of Jasic®, JAVA Script, JSON, AJAX or Action Script depending on the application

Overview of product variants		
Description	Suitable for	Item number
<b>Alert Messenger</b> <sup>*2</sup> Configurable Jasic® program for sending fault messages by email	UMG 604 / UMG 605 / UMG 509 / UMG 512 and PRO series	<b>51.00.209</b>
<b>EN 50160 Watchdog</b> <sup>*2</sup> Integrated "Watchdog"-function for continuous monitoring per EN 50160	UMG 605 / UMG 512	<b>51.00.264</b>
	UMG 605-PRO / UMG 512-PRO	<b>51.00.305</b>
<b>FBM10PT1000</b> <sup>*3</sup> Up to 10 additional thermistor inputs can be implemented via the RS485 interface by means of hardware expansion	UMG 604 / UMG 605 / UMG 509 / UMG 512 and PRO-Serie	<b>51.00.211</b>
<b>GPS Sync</b> Synchronization of the device time via digital input. For usage of the APP the GPS receiver, item no.15.06.240, is required	UMG 604 / UMG 605 / UMG 509 and PRO series	<b>51.00.291</b>
<b>Humidity &amp; Temperature JFTF-I</b> <sup>*4</sup> Processing and recording of up to 8 temperature / moisture sensors possible	UMG 604 / UMG 605 / UMG 509 / UMG 512 and PRO series	<b>15.06.337</b>
<b>IEC61000-2-4 Watchdog</b> <sup>*2</sup> Integrated "Watchdog"-function for continuous monitoring per IEC 61000-2-4	UMG 605 / UMG 512	<b>51.00.265</b>
	UMG 605-PRO / UMG 512-PRO	<b>51.00.306</b>
	UMG 604 / UMG 509	<b>51.00.309</b>
	UMG 604-PRO / UMG 509-PRO	<b>51.00.308</b>
<b>Mini EnMS</b> <sup>*2</sup> Display of current and historical measured values in numbers and diagrams from a master device and max. 15 UMGs without memory, on the device's own homepage	UMG 604 / UMG 605 / UMG 509 / UMG 512 and PRO series	<b>51.00.266</b>
<b>Multitouch</b> <sup>*5</sup> Reading out of 30 measured values and max. 31 slave devices via RS485	UMG 604 / UMG 605 / UMG 509 / UMG 512 and PRO series	<b>51.00.207</b>
<b>Push Service</b> <sup>*2</sup> Sending data directly from the measurement device to a server without any additional software with 10 slave devices	UMG 604 / UMG 605 / UMG 509 / UMG 512	<b>51.00.238</b>
	UMG 604-PRO / UMG 605-PRO / UMG 509-PRO / UMG 512-PRO	<b>51.00.307</b>
<b>Push Service + UMG 20CM</b> <sup>*2</sup> Sending data directly from the measurement device to a server without any additional software For UMG 20CM queries over: UMG 604 / UMG 605 / UMG 509 / UMG 512 and PRO series	UMG 604 / UMG 605 / UMG 509 / UMG 512 and PRO series	<b>51.00.285</b>
<b>RCM analysis</b> Extensive options for setting limit values and analysing fault currents in detail. Up to 20RCM channels can be managed and evaluated via a gateway. The evaluation covers all types of residual current with an associated frequency analysis. In addition, the application enables the proven dynamic limit value formation with Janitza energy measuring devices.	UMG 604-PRO / UMG 605-PRO / UMG 509-PRO / UMG 512-PRO	<b>51.00.312</b>
<b>SNMP</b> <sup>*2</sup> Threshold monitoring with alarm function (SNMP-Trap)	UMG 604 / UMG 605 / UMG 509 / UMG 512 and PRO series	<b>51.00.310</b>

<sup>\*2</sup> Serial number is needed

<sup>\*3</sup> Free APP for item-no. 15.06.077

<sup>\*4</sup> Free APP for item-no. 15.06.074

<sup>\*5</sup> Also needed for BACnet, if slave devices have to be visualized via RS485

## APP Alert Messenger **Item no. 51.00.209**

- Configurable Jasic® program for sending fault messages by email
- Depending on configuration, sending of fault messages with the following events: Total harmonic distortion voltage exceeded, short-term interruption detected, transient detected
- Saving the meter readings for the event and transient messages in the Modbus register
- Option to monitor additional measured values via an interface (not included)
- Emails\*1 with consumption values for day, week and month can be sent (a non-encrypted mail server is required)
- Serial number is needed

**Suitable for:** UMG 604 / UMG 605 / UMG 509 / UMG 512 and PRO series

## APP FBM10PT1000 **Item no. 51.00.211**

- Up to 10 additional thermistor inputs can be implemented via the RS485 interface
- Hardware expansion FBM10 PT1000 – a DIN rail module with 10 PT1000 inputs – necessary for this APP

**Suitable for:** UMG 604 / UMG 605 / UMG 509 / UMG 512 and PRO series



Fig.: Measured value display via the devices' homepage

## APP Humidity & Temperature JFTF-I **Item no. 15.06.337**

- Can process and record the measured values from up to 8 temperature/ moisture sensors (item no. 15.06.074)
- In doing so the display of the measured values is implemented via a homepage after installing the APP, or via global variables in the GridVis®
- Measured values can be saved in a second Jasic® program via the graphical programming
- Delivers two analogue 4 – 20 mA output signals, which will be processed by the function module FBM DI8AI8 (item no. 15.06.079)

**Suitable for:** UMG 604 / UMG 605 / UMG 509 / UMG 512 and PRO series



Fig.: Humidity / temperature sensor JFTF -I

# APP EN 50160 Watchdog

Item no. 51.00.264 & 51.00.305

Integrated “Watchdog” function for continuous monitoring of the power quality per EN 50160. The power quality on the supply side should comply with EN 50160. This standard describes various power quality parameters for the distribution of electrical power on public power grids. EN 50160 pertains to mains voltage, i.e. the voltage measured at the mains connection point. With power quality monitoring per EN 50160, all the algorithms (including for 95% and 100% values) are integrated in the measurement device itself.

**The auxiliary voltage of the device should be buffered to ensure that power failures can be reliably detected as events.**

- Integrated watchdog function
- No need to transmit large volumes of measured data from the measurement device to a host system
- Save on communications costs for applications with remote consumers
- Simple analysis possible thanks to integrated colour display based on a “traffic light” system
- Possible to perform power quality analyses even with no particular knowledge on the topic
- No alarm functionality
- Serial number is needed

Item no. 51.00.264 suitable for: UMG 605 and UMG 512

Item no. 51.00.305 suitable for: UMG605-PRO and UMG 512-PRO

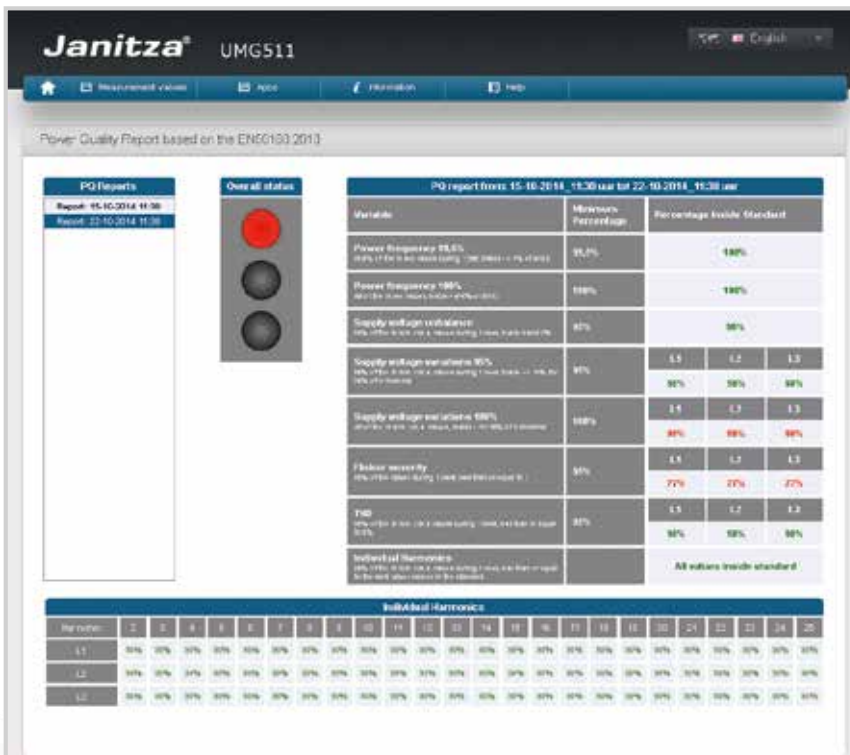


Fig.: APP Power Quality Report based on the EN 50160



# APP IEC 61000-2-4 Watchdog

Item no. 51.00.265 / 51.00.306 / 51.00.309 / 51.00.308

Integrated “Watchdog” function for continuous monitoring of the power quality per IEC 61000-2-4. The standard IEC 61000-2-4 defines numerical limits for industrial and private power distribution systems at rated voltages up to 35 kV. For the consumer, the standard IEC 61000-2-4 should be applied with reference to power quality. Therefore the power quality in all technical systems must be continuously monitored in accordance with IEC 61000-2-4, in order to ensure fault-free operation of the installed system.

**The auxiliary voltage of the device should be buffered to ensure that power failures can be reliably detected as events.**

- Integrated watchdog function accordance with standard IEC 61000-2-4
- No need to transmit large volumes of measured data from the measurement device to a host system
- Save on communications costs for applications with remote consumers
- Simple analysis possible thanks to integrated colour display based on a “traffic light” system
- Possible to perform power quality analyses even with no particular knowledge on the topic
- No alarm functionality
- Serial number is needed

Item no. 51.00.265 suitable for: UMG 605 and UMG 512

Item no. 51.00.306 suitable for: UMG 605-PRO and UMG 512-PRO

Item no. 51.00.309 suitable for: UMG 604 and UMG 509

Item no. 51.00.308 suitable for: UMG 604-PRO and UMG 509-PRO



Fig.: APP Power Quality Analyse acc. to IEC 61000-2-4

# APP Multitouch **Item no. 51.00.207**

- Reads out 30 measured values (fixed default value) from up to 31 slave devices (configurable) via RS485
- Filing of the measured values in the master in global variables or on BACnet data points
- Display of the measured values is implemented via the device homepage (browser with FLASH plug-in necessary)
- Expansion for live value display
- Integrated BACnet gateway function (option, item no. 52.16.083)
- The BACnet-ID can be changed via the homepage
- Program installs a control program
- Possible communications fault (RS485-Bus) directly visible via a status display
- The number of devices and device descriptions can be configured via the master devices homepage
- The master device is automatically recognised and entered in the "device type" field
- The BACnet configuration is likewise implemented via the master device homepage
- Each device can be assigned its own BACnet-ID
- EDE file for the import of the BACnet data points in a BACnet-GLT is included in the scope of deliverables for the APP

**Item no. 51.00.207 suitable for:** UMG 604 / UMG 605 / UMG 96-PN / UMG 96-PA / UMG 509 / UMG 512 and PRO series



Fig.: Overview page of the measured values



Fig.: Configuration page: Assignment of names and basic settings



Fig.: BACnet configuration

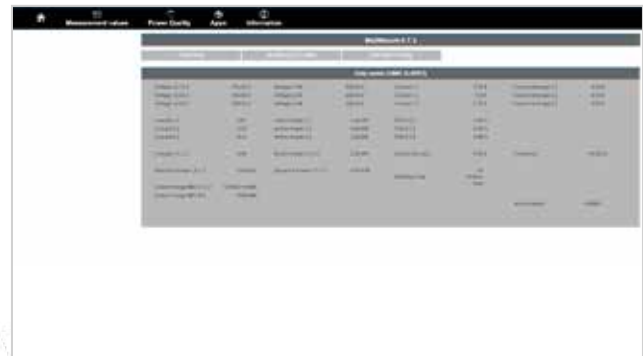


Fig.: Measured value page, slave view

## GPS Sync Item no. 51.00.291

- Synchronisation of the device time via digital input
- No NTP server required
- Easy installation
- Accuracy +/-1 s per GPS synchronization
- A GPS receiver (item no. 15.06.240), available as an accessory, is required
- This APP is not required for the UMG 512-PRO because the GPS receiver can be connected to the digital input 1 without an APP on the UMG 512-PRO

**Suitable for:** UMG 604 / UMG 605 / UMG 509 and PRO series

## SNMP Alert Item no. 51.00.310

- The “Limit value alarm via SNMP” application monitors the settings made on the weg page and in GridVis® and sends an SNMP trap when it is exceeded.
- Freely adjustable trap number
- Until two hosts setable
- Serial number is needed

**Suitable for:** UMG 604 / UMG 605 / UMG 509 / UMG 512 and PRO series



Fig.: Configuration page on an UMG **without** RCM functionality



Fig.: Configuration page on an UMG **with** RCM functionality

# APP Push Service Item no. 51.00.238 & 51.00.307

## Applications

- Sending data directly from the device to the energy portal (without additional software)
- The delivery of data is implemented via port 80
- Data can be saved in a MySQL database automatically
- Data can be visualised via a web server by means of a web browser
- An APP must be installed on each device
- Only Jasic-capable devices are supported (UMG 604-PRO / UMG 605-PRO / UMG 509-PRO and UMG 512-PRO)
- UMG 96RM-EL with integrated Push App function is supported
- Prodata and UMG 20CM – only via Jasic®-capable devices

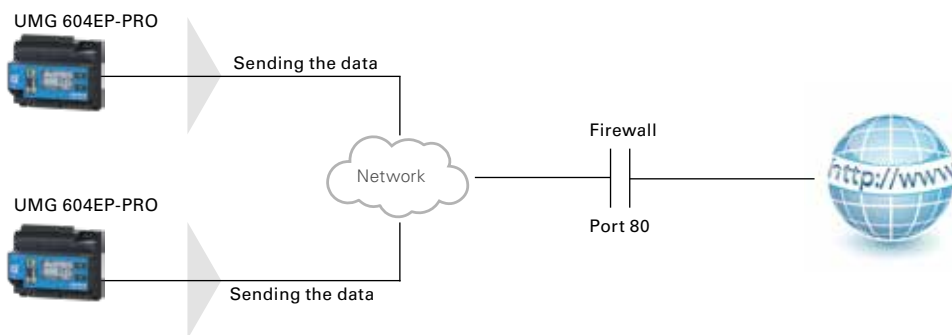


Fig.: Sending the content of the memory for the web application

## Properties

- Sending of up to 25 measured values is possible simultaneously
- Delivery of the last mean values from the ring buffer
- APP automatically detects which data in the ring buffer is saved with which averaging time, and presents these for selection
- The measured values to be sent can be selected via the homepage
- Mean values are automatically synchronised to the device time
- The transmission time can be adjusted for the transmission buffer. In the event of the network connection failing, there are no gaps in the data so long as the failure is shorter than the transmission buffer time
- View of a status display on the homepage with the last data transmitted
- Setting of a daily status email to verify a successful sending process (optional)

## Advantages

- Less data traffic
- Multiple devices can send data simultaneously
- The transmission string can be easily modified to suit individual requirements
- Thus there is an option to send data from external software
- The sending of data is implemented via port 80 (generally enabled with firewalls)
- Decentralisation and thus less susceptible to interference
- The transmission of data can be implemented as randomly controlled, so that there will be no overlapping
- Simple configuration

### Overview of the main features of the APP Push Service 2.0

- Sending of up to 25 measured variables to a "software as a service" program
- Time intervals adjustable via port 80 (via HTTP/Json)
- Configuration implemented via the device website
- APP will be delivered, encrypted, linked to an individual serial number of the UMG device (provision of the serial number necessary)
- Serial number is needed

**Item no. 51.00.238 suitable for:** UMG 604 / UMG 605 / UMG 509 and UMG 512

**Item no. 51.00.307 suitable for:** UMG 604-PRO / UMG 605-PRO / UMG 509-PRO and UMG 512-PRO



Fig.: Push Service 2.0 UMG 604-PRO

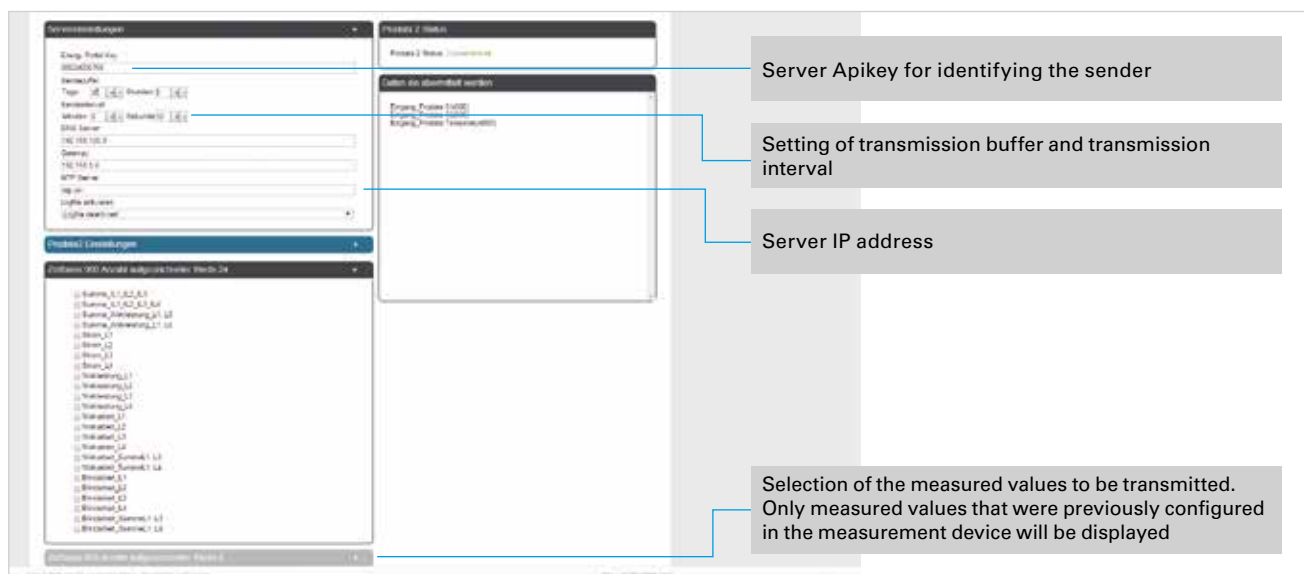


Fig.: Convenient configuration of the APP Push Service 2.0

## APP Mini EnMs Item no. 51.00.266

With the “Mini EnMs” APP you can set up a small, local, web-based energy management system for a maximum of 16 Janitza devices without memory. Online and historical data from the master and slave devices are displayed via the web-based user interface. The master device also acts as a data collector for the slave devices.

- Optimised for use on desktops, laptops or tablets
- Select measured variables for the master device and slave devices using drag & drop
- Select the desired time window with the integrated calendar function
- The main variables of the Modbus slaves are stored and displayed on the “main measurement device”
- No external server or software package needed; just a standard browser will suffice
- Maximum of 16 slaves (UMG 103-CBM or UMG 96RM)
- Memory variables for slave devices
  - Current L1, L2, L3
  - Total effective power
  - Total apparent power
  - Total effective energy
- The master collects the data and presents it on its own device homepage. The APP was developed for small applications where GridVis® ist not being used.
- Serial number is needed

**Suitable for:** UMG 604 / UMG 605 / UMG 509 / UMG 512 and PRO series

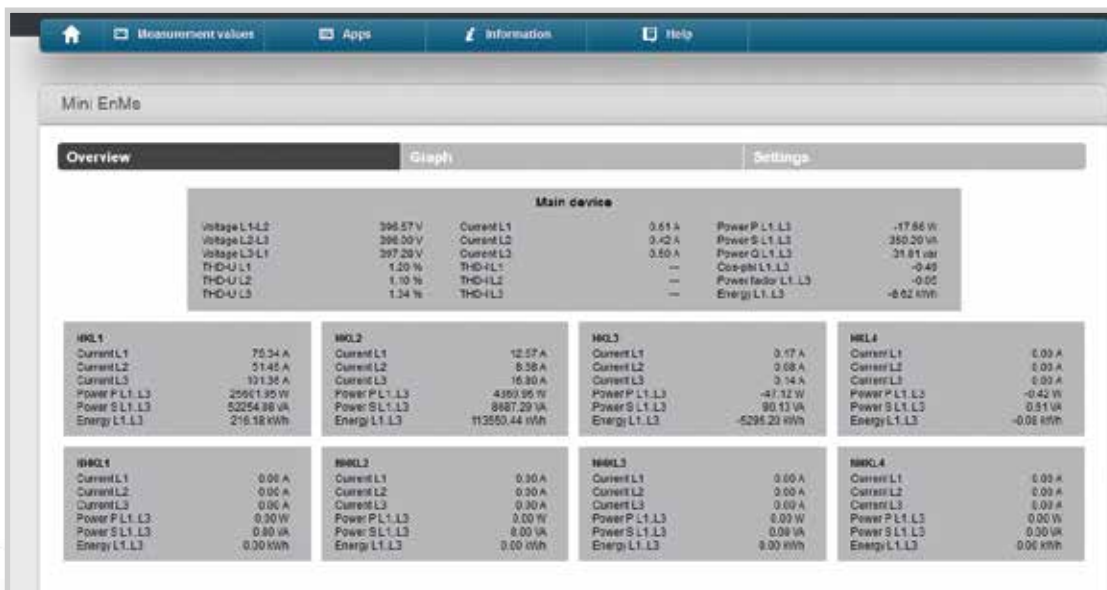
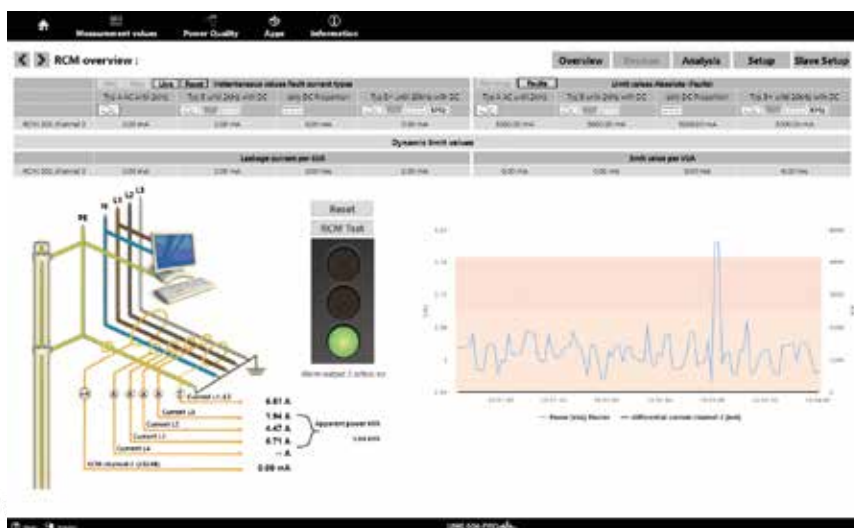


Fig.: APP Mini EnMS

## APP RCM analysis Item no. 51.00.312

- APP with extensive options for setting limit values and analysing fault currents in detail
- Up to 20 RCM channels can be managed and evaluated via a gateway
- The evaluation covers all types of residual current with an associated frequency analysis
- For example, 50 Hz, pure DC or high-frequency residual currents in the 20 kHz range can be displayed individually
- In addition, the application enables the proven dynamic limit value formation with Janitza energy measuring devices
- Energy measuring devices can be assigned to each of the 20 RCM channels and limit values can be calculated as a function of power



# Device homepage

Power management and power quality analysis online

The device-specific homepage for the measuring devices is ideal for users or target groups within a company, who do not wish to install the GridVis® Power Grid Monitoring Software or do not require it. For access to this, the user simply requires a conventional web browser and an Ethernet connection (or a local patch cable). The screens have been graphically revised and have now been made even more user-friendly. Each measuring device has an integrated web server, which makes a separate, password-protected homepage available. It is possible to operate the device just as comprehensively via this, as via the device display. Furthermore, extensive online and historic measuring data (standard power consumptions), including the power quality analysis, can also be called up. It is even possible to control the measuring device remotely and configure it via the display indications. Because a multitude of PQ measured values can be displayed in addition to the countless standard electrical values, for many users the measuring device homepage constitutes the basic configuration for a monitoring system.

- Access to the powerful meter-homepage via web browser
- No software installation necessary
- Real-time data, historical data etc. directly accessible via the meter home page
- Function extension via APPs possible
- Remote control of device display via homepage
- Password protection possible



Fig.: IEC 61000-2-4 analysis with traffic-light principle

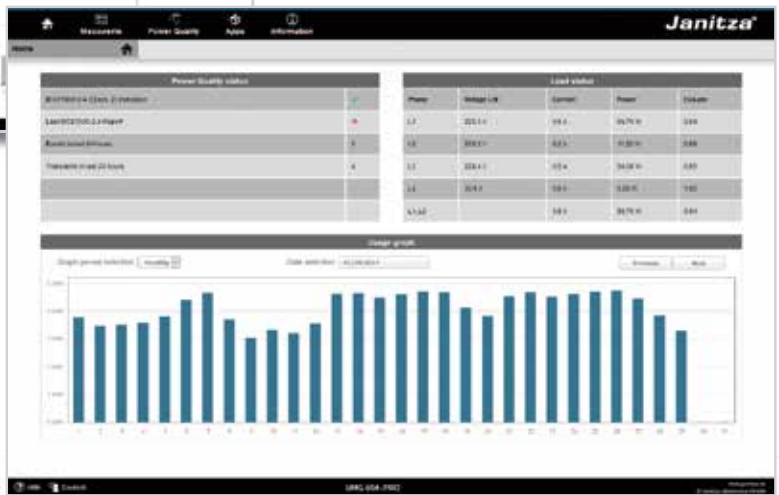
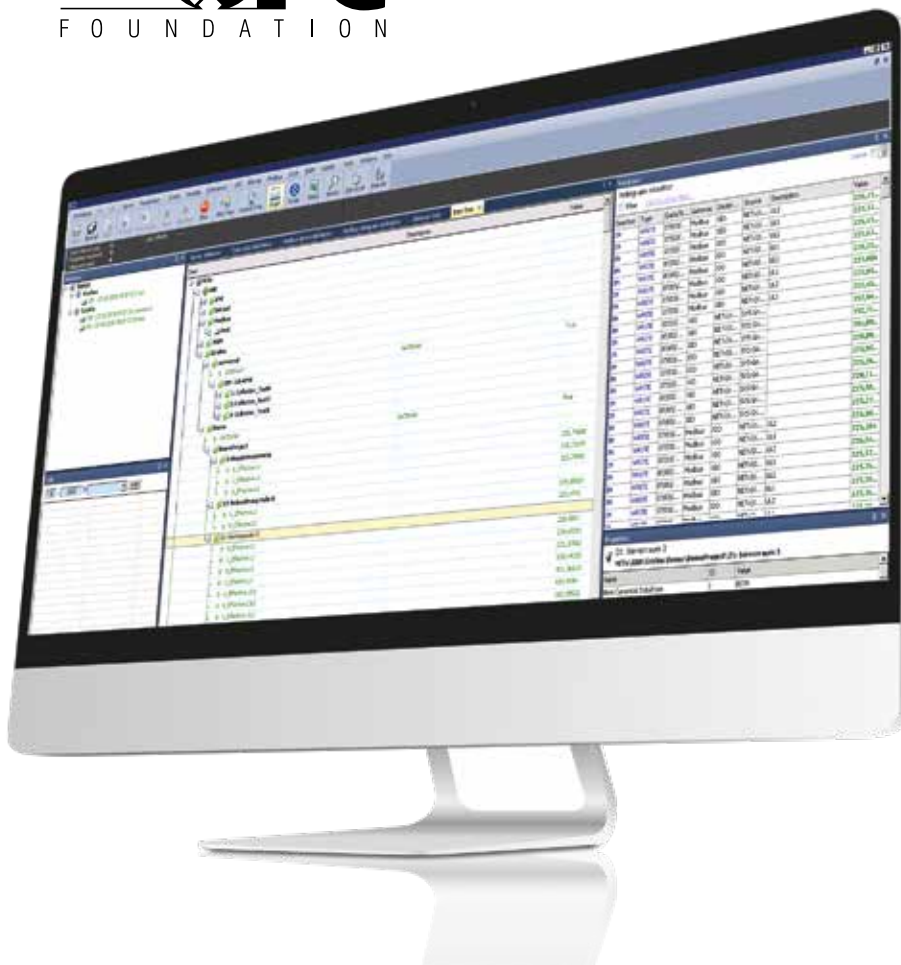


Abb.: Power Quality status overview



# MULTI PROTOCOL SERVER



# Multi Protocol Server

## Increase connectivity

Extend the GridVis® connectivity with the Multi Protocol Server from NETx-Automation and take advantage of the option to offer measurement data at OPC UA level. The Multi Protocol Server from NETxAutomation, with the integrated GridVis® driver, is available exclusively from Janitza and can be used in addition to the OPC UA client.

The server enables direct access to measurement data and key performance indicators of GridVis®. The clear advantages of the integrated driver include low setup costs and uptime of all measurement data. In addition, the complete GridVis® measurement device structure is directly available in the OPC UA tree. Several GridVis® projects can also be mounted. OPC UA clients, such as the GridVis® OPC UA client, building management systems, SCADA systems, ERP systems and many more can thus easily process GridVis® online data. **In addition to the direct GridVis® connection, the Multi Protocol Server offers KNX, BACnet, Modbus, SNMP, OPC, MQTT as well as logic functions, which are already included in the delivery.** Our partner NETxAutomation, provides support with its many years of experience in the field of OPC UA and building automation. Janitza specialists are optimally trained to assist you with the server installation and commissioning.

Note: The Multi Protocol Server is an independent application and can be acquired in addition to GridVis®. Billing is based on the required data points. We will be happy to make you an individual offer.

Description	Item no.
Multi Protocol Server 1000 – compatible with GridVis® Edition Standard and Expert*	51.00.155
Multi Protocol Server 2500 – compatible with GridVis® Edition Standard and Expert*	51.00.156
Multi Protocol Server 5000 – compatible with GridVis® Edition Standard and Expert*	51.00.157
Multi Protocol Server 10000 – compatible with GridVis® Edition Standard and Expert*	51.00.158

\* The Multi Protocol Server is also compatible with the GridVis® editions Service and Ultimate.



# DATABASE SERVER



## Database server

### **Comprehensive monitoring and analyses require powerful server solutions**

- Janitza electronics GmbH offers a powerful server as a complete solution
- Trouble-free and immediate use is guaranteed
- Simple and rapid integration of the pre-configured server into the existing network
- GridVis® Power Grid Monitoring Software is already installed on the database server
- Available databases: Janitza DB, MS SQL or MySQL
- Application of a powerful tower or rack server from Dell
- The Dell PowerEdge server offers high quality and reliability with maximum expandability
- A RAID-10 system with hot-plug hard drives guarantees a high standard of data security



Fig.: Server (tower)

### **Guaranteed all-round service**

- Access to the database server thanks to Janitza maintenance diagnostics and fault rectification (only with authorisation)
- Rapid diagnostics and rectification of problems possible
- Highest level of security: Use of common remote maintenance solutions with three-stage encryption per industry standards



Fig.: Server (rack)

### **For larger projects we currently recommend the following configuration:**

- Current Intel processor
- 16 GB RAM
- RAID controller
- RAID 10 with 4 hard drives, 1 TB capacity each
- DVD-ROM drive
- Windows 2008 Server with 5 CALs, 64 Bit (German or English version)
- Installation of GridVis® Power Grid Monitoring Software and the database driver for SQL servers
- MySQL / MS SQL databases should be provided by the client
- The integration of the server into the company's own network must be implemented by the customer's own administration

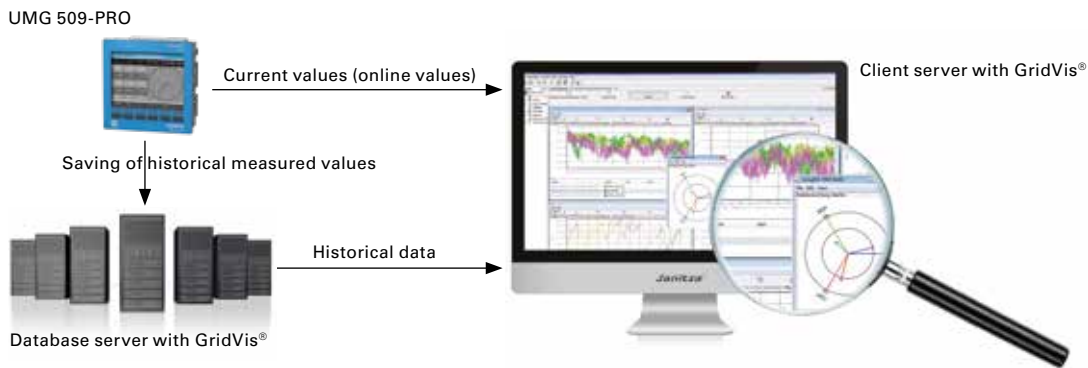


Fig.: The UMG 509-PRO, for example, currently has 6 communication ports. Of these, two are designed as gateways (port 8000) for downstream RS485 devices.

### Areas of application

- With extensive monitoring systems with a large number of measurement devices
- For applications that require a high degree of data security and maximum performance
- With companies whose systems must be scalable and expandable

### Application

- GridVis® runs as a service on the server
- Log-in of a user not required for automatic data logging
- For measured value analysis the client computer accesses the server directly via the network
- Access to measurement data within the database by any number of client systems possible
- Display of online measurement values dependent of the number of ports per device, i.e. visualisation of historical data via the database, online measurement values available direct from the UMG device



Product overview		
Description		Item no.
Server (tower)	<ul style="list-style-type: none"> <li>• Current Intel processor</li> <li>• 16 GB RAM</li> <li>• RAID controller</li> <li>• RAID 10 with 4 hard drives, 1TB capacity each</li> <li>• DVD-ROM drive</li> <li>• Incl. mouse and keyboard with german layout</li> </ul>	<b>15.06.352</b>
	<ul style="list-style-type: none"> <li>• Windows 2012 Server with 5 CALs, 64 Bit (German or English version)</li> </ul> <p><b>Note:</b></p> <ul style="list-style-type: none"> <li>• GridVis® Power Grid Monitoring Software and database driver for SQL server</li> <li>• MySQL / MS SQL databases should be provided by the customer</li> <li>• The integration of the server into the company's own network must be implemented by the customer's own administration</li> <li>• Warranty from Dell GmbH</li> </ul>	(Windows version, German) <b>15.06.353</b>  (Windows version, English)
Server (rack)	<ul style="list-style-type: none"> <li>• Current Intel processor</li> <li>• 16 GB RAM</li> <li>• RAID controller</li> <li>• RAID 10 with 4 hard drives, 1TB capacity each</li> <li>• DVD-ROM drive</li> </ul>	<b>15.06.354</b>
	<ul style="list-style-type: none"> <li>• Windows 2012 Server with 5 CALs, 64 Bit (German or English version)</li> </ul> <p><b>Note:</b></p> <ul style="list-style-type: none"> <li>• GridVis® Power Grid Monitoring Software and database driver for SQL server</li> <li>• MySQL / MS SQL databases should be provided by the customer</li> <li>• The integration of the server into the company's own network must be implemented by the customer's own administration</li> <li>• Warranty from Dell GmbH</li> </ul>	(Windows version, German) <b>15.06.355</b>  (Windows version, English)
Setup package 1 for MS SQL	<ul style="list-style-type: none"> <li>• Install hard drives</li> <li>• Install operating system</li> <li>• RAID configuration (RAID 10)</li> <li>• Install updates</li> <li>• Install MS SQL Server*</li> <li>• Install GridVis®</li> </ul>	<b>51.01.018</b>
Setup package 2 for My SQL	<ul style="list-style-type: none"> <li>• Install hard drives</li> <li>• Install operating system</li> <li>• RAID configuration (RAID 10)</li> <li>• Install updates</li> <li>• Install MySQL Server*</li> <li>• Install GridVis®</li> </ul>	<b>51.01.019</b>
Setup package 3 for JanDB	<ul style="list-style-type: none"> <li>• Install hard drives</li> <li>• Install operating system</li> <li>• RAID configuration (RAID 10)</li> <li>• Install updates</li> <li>• Install JanDB</li> <li>• Install GridVis®</li> <li>• Install RTP user</li> </ul>	<b>51.01.023</b>

\* The MS SQL or MySQL database should be provided by the customer. GridVis® Power Grid Monitoring Software and database drivers are separate items. The integration of the server into the company's own network must be implemented by the customer's own administration. Hardware warranty from Dell GmbH.



Fig.: Server (tower)



Fig.: Server (rack)

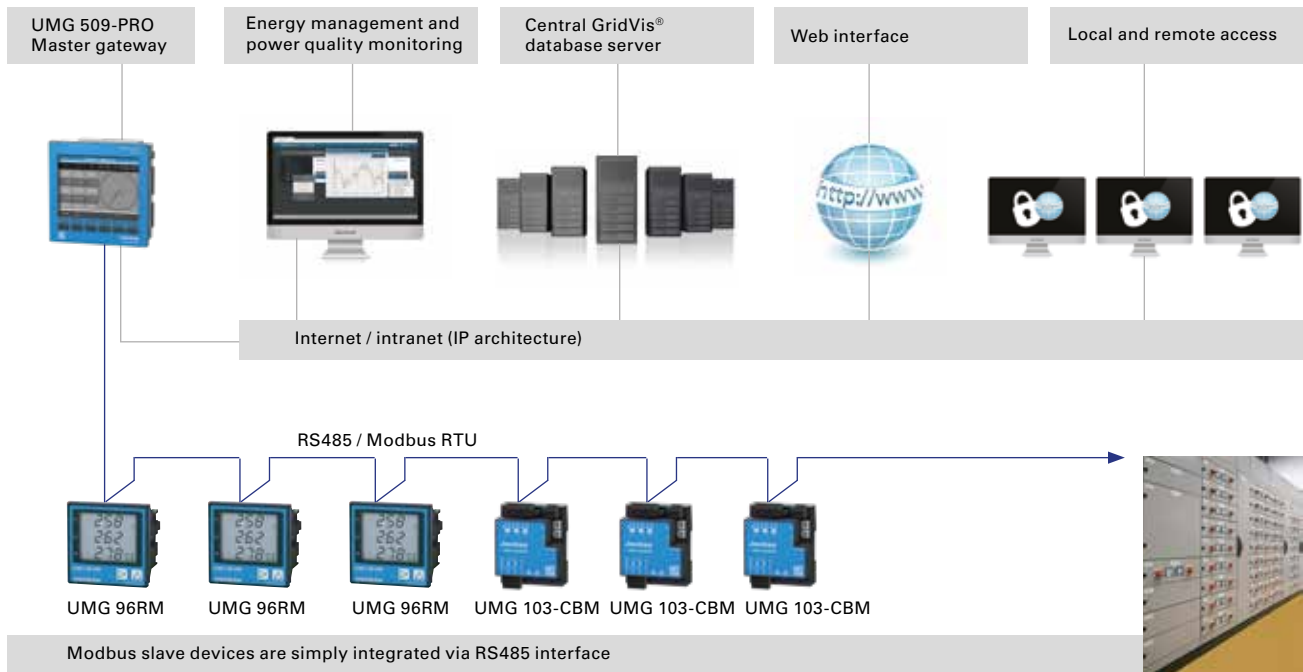


Fig.: Master-Slave communication architecture

# 05 Industrial data communication

- Mobile communication modem – EasyGateway EG400
- Gateway MBUS-GEM
- PowerToStore – UPS system with extension
- D-SUB bus connector
- USB converter and repeater
- Industrial power supply for DIN rail mounting
- Touch panels – user-friendly visualisation of measured values without PC, directly at site





# INDUSTRIAL DATA COMMUNICATION



## LTE modem EasyGateway V50

### Data connection and simple commissioning

- Communication Gateway for wireless and hard-wired communication
- The EasyGateway V50 connects the UMG measuring devices with Ethernet interface with the PC via LTE network
- The Power Grid Monitoring Software GridVis® includes a driver, which enables the simple establishment of a connection with the measuring devices via the V50
- Connection of the EasyGateway to the measuring device
- Setting up the measuring device in GridVis® and selection of the EasyGateway communication
- Activation of the connection via GridVis® necessary
- Suitable for: UMG 604-PRO, UMG 605-PRO, UMG 96RM-E, UMG 509-PRO und UMG 512-PRO
- Connection of the following devices via RS485 (max. 10–15 devices): UMG 96-PA / UMG 96-PA-MID / UMG 96-PA-MID+ / UMG 96 PQ-L / UMG 96RM-CBM / UMG 103-CBM



### Managed Service – Connect-2-Control\*1

- Connect-2-Control (C2C) is a simple and secure managed solution
- Simple access to the measuring device (location-independent) is guaranteed via public IP networks (internet, mobile data networks, company networks)
- Certificate-protected security (SSL)
- SSL-encrypted from the PC to the Gateway
- No VPN tunnel required
- Managing static IP addresses

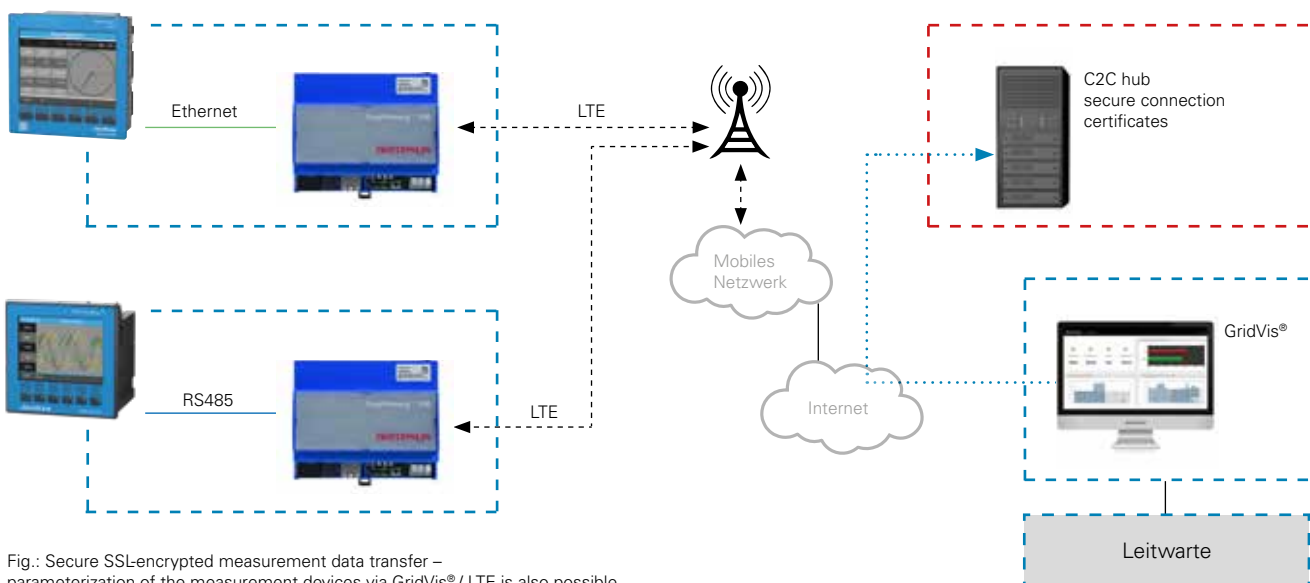


Fig.: Secure SSL-encrypted measurement data transfer – parameterization of the measurement devices via GridVis® / LTE is also possible

\*1 The connect-2-control service for the administration of the local, static IP addresses of our Janitza devices as well as the startup is offered by aartesyS. The relevant application form is included to the shipment of the EasyGateway or can be downloaded under <https://www.janitza.com/c2c-service>



## Technical data

EasyGateway V50 LTE Cat4, LAN, RS485	15.06.110
EasyGateway V50 LTE Cat4, LAN	15.06.111
<b>Display elements</b>	3 LED, bicolor red/green, for commissioning and operating display 1 LED orange GSM status
<b>Communication</b>	Unrestricted internet connectivity with certificate-based authentication and encryption
<b>LAN/WAN-Anschluss</b>	Fast Ethernet 10/100Mbps, Auto-MDIX, RJ45, shielded, 2 status LED
<b>Mobile communication</b>	GPRS (quad band GPRS class 10) or HSPA+ (dual band GSM/GPRS/EDGE, dual band UMTS/HSPA) or LTE
<b>SIM</b>	Pluggable and/or solderable SIM (SIM multiplexer)
<b>Local IP interface</b>	Fast Ethernet 10/100Mbps, Auto-MDIX, RJ45, shielded, 2 status LED
<b>Local serial interfaces</b>	RS485, RS422 and RS232 via the USB adapter
<b>Power supply</b>	85 up to 264 V AC, optional 18 up to 75 V DC or 9 up to 27 V DC
<b>Housing</b>	85 up to 264 V AC, optional 18 up to 75 V DC or 9 up to 27 V DC
<b>Environment</b>	Temperature range -20 °C – +70 °C, relative humidity max. 95%
<b>Dimensions in mm (W x H x D)</b>	1075 x 90 x 62 mm
<b>Weight</b>	280 g
<b>Accessories</b>	<b>Item number</b>
INOX antenna mounting bracket	15.06.094
LTE antenna for outdoor installation	15.06.115
Extension cable, 2 m	15.06.099
Extension cable, 5 m	15.06.091
Extension cable, 10 m	15.06.092

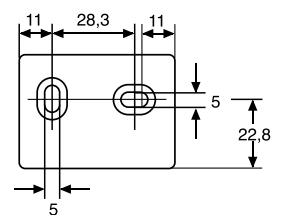
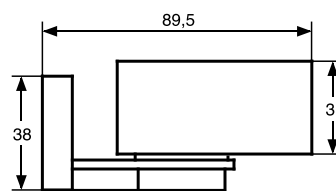
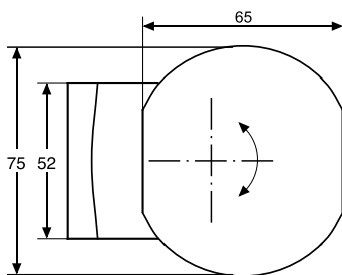
## GPS radio receiver

### Main features

- Works worldwide
- Receive and process the GPS time signal (GMT)
- For time synchronisation of the measuring devices UMG 604-PRO\*1, UMG 605-PRO\*1, UMG 96-PA, UMG 96-PA-MID+, UMG 508\*1, UMG 509-PRO\*1, UMG 511 und UMG 512-PRO
- 1 digital connection controls up to four UMGs
- Wall mounted
- Small, compact construction
- Easy to install, housing screws into mounting bracket
- Check LED on the housing
- Connection using three-wire shielded cable
- Connection voltage 21 – 28 V / DC
- External power supply necessary



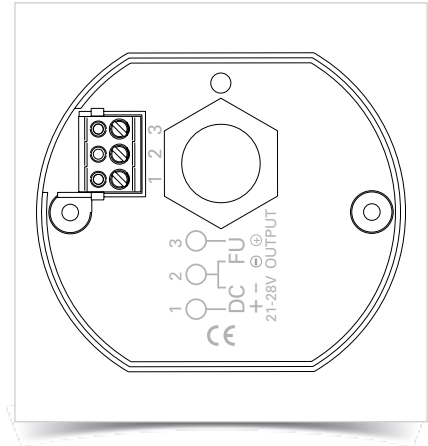
### Dimension diagrams





## Technical data

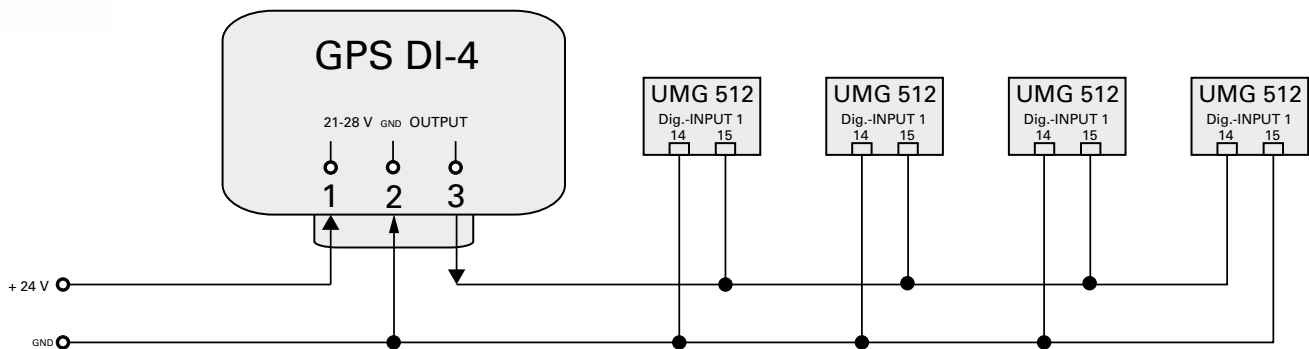
Technical data	
Item number	15.06.240
Synchronization accuracy with the UMG 512-PRO	20 ms (compared to the UTC time)
Synchronization accuracy with the UMG 604-PRO, UMG 605-PRO, UMG 508, UMG 509-PRO and UMG 511 <sup>*1</sup>	1 s (compared to the UTC time)
Connection voltage	21 – 28 V / DC Supply = External
Power consumption	Ø up to 100 mA
Output signal	GPS time synchronous pulse signal Adjustable via DIP switches Pulse for minutes (1 sec.) and/or hours (5 sec.) I <sub>max</sub> 50 mA
Protection class	IP 54 acc. to DIN EN 60529
Ambient temperature	-30 °C to 55 °C
Regulations / Test marks	EN 60730 / CE
Housing	Self-extinguishing thermoplastic
Installation type	Wall mounted with mounting bracket
Recommended cable(s)	Shielded/cable section 0.33 to 2.5 mm <sup>2</sup>



<sup>\*1</sup> Please note: For the measuring devices UMG 604, UMG 605, UMG 508, UMG 509 and UMG 511 the APP GPSTIMESYNC (21.00.291) is needed.



## Typical connection



# Gateway MBUS-GEM

## M-Bus Gateway on Modbus TCP

- Communication interface for the integration of consumer meters in GridVis®.
- Connection at control level
- Standard per IEC6115
- Supply voltage: 24 V DC +/- 5%, screw-type terminal
- M-Bus per EN 13757-2, screw-type terminal
- Ethernet 100 MBit, RJ45 socket, screened
- High-performance driver for the connection of up to 80 standard loads
- Highly compact design (W x H x D in mm) 35 x 89 x 58
- Spatial requirements 2TE wide for mounting on DIN rail 35 mm
- Galvanic separation from the M-Bus and RJ45
- Suited for use in industrial areas
- Requirement: GridVis® Expert & commissioning

Commissioning by Janitza is recommended.  
For more detailed information please refer to chapter 9.



## Technical data

MBUS-GEM Gateway	
Item number	15.06.108
Architecture	Controller-based gateway
Supply	24 V DC, < 300 mA, max. 2.5 mm <sup>2</sup>
M-Bus connections	Screw-type terminal, max. 2.5 mm <sup>2</sup>
Ethernet connection	100 MBit, RJ45, screened
Dimensions	35 x 89 x 58 (W x H x D in mm)
Assembly	DIN mounting rail 35 mm, IP40
Max. Baud rate	300, 2400 or 9600 bps
Number of slaves	max. 80 standard loads
IP address	freely configurable or by DHCP
TCP port	freely configurable

# PowerToStore

## Buffer power supply with capacitors

- Typically serves to bridge short term interruptions
- Operates with integrated ultra-capacitors for energy storage
- With a supply voltage interruption, the stored energy of the ultra-capacitors is released on a regulated basis
- A buffer module feeds the load up to full discharge
- The buffer time is dependent on the charge status of the capacitor and the height of the discharge current
- Can be used only with 24 V UMG devices

## Main features

- Lifelong maintenance-free
- Compact housing
- Deep-discharge proof consequently unlimited storage time
- Operation possible under extreme temperature conditions
- No gas generation, therefore installation in hermetically-sealed housings possible
- Rapid availability because short charging time after discharging



## Technical data

PowerToStore (PTS)	
Item number	15.06.405
<b>Input</b>	
Nominal input voltage	115 – 230 V AC
Stored energy in Ws	1,000
<b>Output</b>	
Output voltage in buffer operation	24 V DC constant
Nominal output current	3 A
Current limiting	1.05 ... 1.2 x INom
Degree of efficiency $U_a = 23.5 \text{ V DC}$ , $I_a = I_{Nom}$	> 90 %
<b>General data</b>	
Connection type input $U_E$	2.5 mm <sup>2</sup> cable cross section
Connection type output $U_A$	2.5 mm <sup>2</sup> cable cross section
Connection type I/Os	1 mm <sup>2</sup> cable cross section
Protection class	IP20
Type	PTS2403
Storage temperature	-40 ... +60 °C
Ambient temperature	-40 ... +60 °C
Weight	1.2 kg
Dimensions in mm (H x W x D)	153 x 72 x 130

### Note:

The power quality analysers UMG 604-PRO / UMG 605-PRO / UMG 96RM are supplied during short term interruptions of up to 225 sec. by the buffer device (item no. 15.06.405). With the power quality analysers UMG 509-PRO / UMG 512-PRO, the expansion unit (item no. 15.06.406) is additionally required. With this configuration short term interruptions lasting up to 256 sec can be bridged.

## D-SUB bus connector

### Main features

- For RS485 (Modbus and Profibus) with the measurement devices UMG 604-EP, UMG 605-PRO, UMG 96RM-P, UMG 509-PRO and UMG 512-PRO
- D-sub connector, 9-pole
- With termination (switch on/off termination resistors)
- Axial design with two cable feeds
- Bus system: PROFIBUS DP up to 12 MBit/s
- Termination resistor can be switched in via Dip switch
- Pin assignment: 3, 5, 6, 8
- Screw-type terminal connection



Fig.: SUBCON-PLUS-PROFIB/AX/SC  
(item no. 13.10.539)



### Technical data

D-SUB bus connector	
Item number	13.10.539
Item number	13.10.543*
Nominal voltage	50 V
Rated current	100 mA
Termination resistor	390 Ω – 220 Ω – 390 Ω (can be switched in)
Bus system	PROFIBUS DP
Max. number of plugin cycles	> 200
Connection	D-SUB plug-in connection
Number of poles	9
Connection	Print connection
Connection type	Screw terminal
Cable diameter max.	8.4 mm
Cable diameter min.	7.6 mm
Operating temperature range	-20 ... +75 °C
Storage / transport temperature range	-25 ... +80 °C
Weight	38.6 g
Dimensions in mm (H x W x D)	17 x 31.5 x 58.2
Housing material	ABS, metallized
Pin assignment:	3, 5, 6, 8

\* 90° bent version



Fig.: SUBCON-PLUS-PROFIB/SC2, 90° bent version  
(item no. 13.10.543)



## K-7510: RS485 repeater, isolated

### Main features

- One RS485 input and output respectively for the expansion of an RS485 network by a further 32 UMG devices and by a further 1.2 km transfer length
- Twin and four-wire operation RS485
- Galvanic separation up to 3 kV DC
- Automatic direction detection
- Automatic Baud rate detection
- Insulated interface
- Suitable for: UMG 103-CBM, UMG 604-PRO, UMG 605-PRO, UMG 96RM, Prophi®, ProData®
- Separate power supply required



Fig.: Figure similar



### Technical data

RS485 repeater, isolated	
Item number	15.06.024
RS485 network expansion	by a max. length of 1.2 km and by 32 modules
Support	up to 256 RS485 devices
Max. number of repeaters per network	8
Insulation	up to 3,000 V DC
Power consumption	1.2 W
Interface connections	with screw-type terminals
Installation	DIN rail or wall mounting
Operating temperature range	-25 ... +75 °C
Weight	157 g
Dimensions in mm (H x W x D)	121 x 72 x 25

**Note:** Repeater is not suitable for Profibus.

## K-7513: RS485 to 3 x RS485 Hub

### Main features

- 1 x RS485 input and 3 x RS485 output for a RS485 star type network
- Galvanic separation up to 3 kV DC
- DIN rail or wall mounting
- Suitable for: UMG 103-CBM, UMG 604-PRO, UMG 605-PRO, UMG 96RM, Prophi®, ProData®
- Separate power supply required



Fig.: Figure similar



## Technical data

RS485 to 3 x RS485 Hub	
Item number	15.06.035
Input	1 x RS485, twin wire (D+, D-)
Output	3 x RS485, twin wire (D+, D-)
Transmission rate	300 to 115.2 kbps
Insulation	up to 3000 V DC
Supply voltage	10 to 30 V DC
Power consumption	2.2 W
Connections	detachable screw-type terminals
Installation	DIN rail or wall mounting
Operating temperature range	-25 ... +75 °C
Weight	157 g
Dimensions in mm (H x W x D)	121 x 72 x 33
Miscellaneous	each I/O interface is equipped with its own line driver, max. 1.2 km line length per interface

# USB/RS485 converter cable

## Main features

- Cable length 1.8 m, expandable up to 20 m
- FTDI chip
- -40 °C up to 85 °C operating temperature range



Fig.: USB/RS485 converter cable



## Technical data

USB/RS485 converter cable	
Item number	15.06.107
Cable „Yellow“	Terminal A of the RS485 interface of the measurement device
Cable „Orange“	Terminal B of the RS485 interface of the measurement device
Baud rate	9600, 19200, 38400 and 115 kBaud
Stopp bits	1 or 2
Parity	EVEN, NONE, UNEVEN

## Switching power supply for DIN rail mounting

### Main features

- 100–240 V wide range input
- Adjustable output voltage
- Compact design, width only 22.5 mm
- Simple mounting onto the DIN rail
- Full power between –10°C and +60°C



### Technical data

Switching power supply for DIN rail mounting	
Item number	16.05.012
Input	
Input frequency	50 – 60 Hz, ±6%
Input voltage	100 – 240 V AC, –15% / +10%
Input current	0.54 / 0.3 A at 120 / 230 V AC
Output	
Output power	30 W
Output voltage	24 V DC ... 28 V DC adjustable
Output current	1.3 A at 24 V 1.1 A at 28 V
General data	
Connection	Screw-type terminal
Installation	DIN rail
Operating temperature range	–10° C to +70° C
Weight	140 g
Dimensions	75 x 22.5 x 91 mm (H x B x T)

## Switching power supply with step shape/DIN rail

### Main features

- Universal input 85~264 V AC (277 V AC operational)
- No load power consumption < 0.3 W
- Isolation class II
- DC output voltage adjustable
- Protections: short circuit / overload / over voltage
- Cooling by free air convection (working temperature: -30 °C ... +70 °C)
- DIN rail TS-35/7.5 or 15 mountable
- Over voltage category III
- LED indicator for power on



### Technical data

Switching power supply with step shape/DIN rail	
Item number	16.05.014
Input	
Input frequency	47 – 63 Hz
Input voltage	85 – 264 V, universal input 110 – 230 V
Output	
Output power	100 W
Output voltage	24 V
Output current	4,2 A
General data	
Technology	AC/DC
Installation	DIN rail
Operating temperature range	-30° C to +70° C
Weight	270 g
Dimensions	70 x 90 x 54,5 mm (W x H x D)

## Energy monitoring – visualisation of the energy measured values of up to 33 devices

### **Display of all energy measured values**

Visualisation & monitoring of Modbus-enabled Janitza UMGs

### **3 master & 30 slaves**

Flexibly selectable number of assignments of slave devices to a master device

### **Direct Modbus connection**

Connection of slave devices via RS485

### **Web-enabled**

Direct, worldwide access to the UMG device homepage



# Intuitive operation directly at the system switch cabinet

## Visualisation

- Display of all current and energy measured values
- Display and storage of the last minimum and maximum values
- Topology view of the connected devices
- Visualisation of the main and ancillary measurements

## User management

- Password-protected display
- Creation of a hierarchical user structure
- User rights

## Alarm

- Integrated alarm management
- Acknowledgement of pending alarms
- Saving of historical alarms
- E-mail notification

## Configuration

- Dynamic topological configuration of up to 33 devices
- Group transfer of the configuration
- Plug & Play configuration via USB:
  - import and export of device configurations
- Labelling of the individual measurement channels, threshold values can be set per channel, etc.
- Factory pre-configured

## Data exchange

- Display of the device homepage
- Export of measurement data via USB
- Optional remote access

## Compatibility

- Access to master and slave devices via GridVis®
- Reporting function



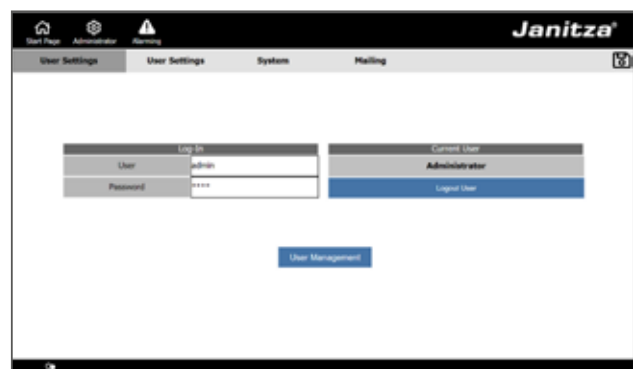
Topological view of the measured values



Configuration of all communication-enabled Janitza Modbus master and slave devices



Alarm list with acknowledgement function



User management with assignment of rights



## Technical data

<b>Item no.</b>	<b>15.06.358</b>
<b>General information</b>	
Net weight	approx. 900 g
Dimensions	282 mm x 184 mm x 35 mm
Backlight (LED)	Brightness: approx. 450 cd/m <sup>2</sup>
Chip	Rockchip RK3288 Quad-Core CPU 1,6 GHz
Processor	2 GB DDR3 SDRAM
Integrated memory	8 GB eMMC
Cut-out size	± 261 mm x ± 164 mm

<b>Interfaces</b>	
USB	– USB 2.0 Type A – Micro-USB
Ethernet	– RJ45 – 10/100 MBit/s
RS485	Modbus RTU/Master

<b>Display</b>	
Type	TFT Color
Diagonal	10"
Resolution	1024 px x 600 px
Touchscreen	Capacitive multitouch

<b>Electrical properties</b>	
Supply voltage	– 24 V DC (via plug-in connection) – 12 V DC (via jack connection)
Max. power consumption	13 W

<b>Ambient conditions</b>	
Protection type according to EN 60529	IP53 frontside, IP20 backside
Operating temperature	0 to 35 °C
Storage and transport temperature	0 to 70 °C
Relative humidity (non-condensing)	10 to 90%





# 06 Current / voltage transformers and sensors

**Current transformers**

Page 243

- Moulded case current transformers, class 0,5 and 1
- Moulded case current transformers for billing purposes, class 0,5 and 0,2S
- Low-power current transformers, class 0,5
- Summation current transformers for moulded case (feed through type) and split core, class 1 and 0,5
- Summation current transformers for cable type (KUW) split core current transformers, class 1
- Cable type split core current transformers, class 0,5; 1 and 3
- Cable split core current transformers type KBU, class 0,5 and 1
- Three-phase current transformers, class 0,5 and 1
- DIN rail current transformer with voltage tap and fuse, class 0,5 and 1
- Compact current transformers, class 1
- Split-core current transformers, class 1
- Split-core operating current transformers up to 600 A, class 1
- Flexible current transformers

**Residual current transformer for RCM Monitoring**

Page 267

- Split-core residual current transformers type KBU
- Split-core residual current transformers type CT-AC RCM
- Feedthrough residual current transformers type CT-AC RCM
- Residual current transformers type B+
- Residual current transformers type A
- Current transformers for operating and differential current type CT-20 for the UMG 20CM
- Current transformers for operating and differential current type SC-CT-21 for the UMG 20CM
- 6-fold DIN rail current transformer type CT-6-20 for the UMG 20CM

**Accessories**

Page 279

- Voltage transformer
- Voltage tap with and without integrated fuse
- Current transformer terminal block with short-circuiting, measurement and calibration possibility
- Humidity and temperature sensor JFTF-I



# CURRENT/VOLTAGE TRANSFORMERS AND SENSORS



# Moulded case current transformers, class 0.5 ... / 5 A

**Increased reliability**

- Both halves of the housing overlap rather than butting up against one another
- Break-proof plastic housing made from polyamide
- Non-combustible per UL 94 VO and self-extinguishing

**Protective caps for primary bus bar fastening screws**

- Fixing screws pins for the primary rail can be insulated by means of protective caps, available as an option
- Safeguard to prevent accidental contact

**Secondary connections**

- Feeding of the secondary connections to the connection terminals through the rectangular opening in the front and rear sides
- Secondary connection by means of cable lugs through the side slots

**Expanded secondary terminal covering**

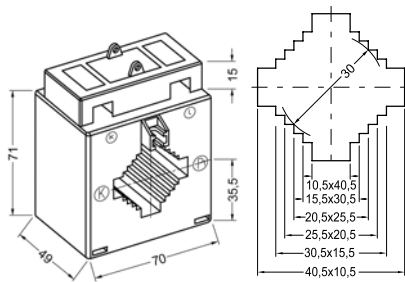
- In addition to the normal terminal covering, extra protective hoods are available
- Locking of the front and rear feed to the secondary terminals



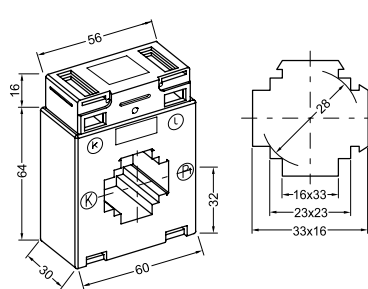
## Dimension diagrams

All dimensions provided in mm

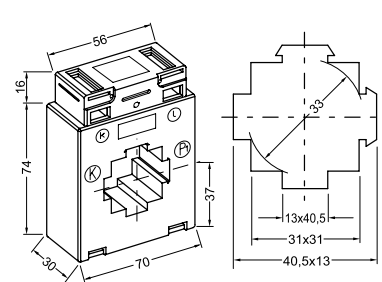
**IPA40.5**



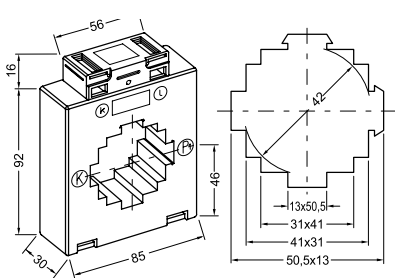
**6A315.3**



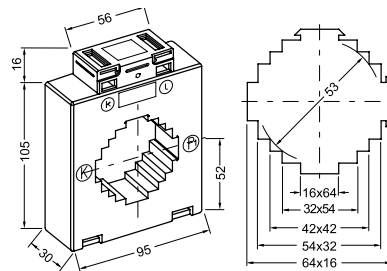
**7A412.3**



**8A512.3**



**9A615.3**



### General mechanical properties

- Nominal frequency 50 – 60 Hz
- Insulation class E (other classes on request)
- Thermal rated short-term current  $I_{th} = 60 \times I_N/1s$
- Rated surge current  $I_{dyn} = 2.5 \times I_{th}$ , min., however 100 kA
- Highest voltage for operating equipment  $U_m = 0.72$  kV
- Rated insulation level (test voltage) 4 kV / 1 min (per EN 61869-2)
- Over-current limit factor FS5 or FS10
- Harmonics currents up to 50th harmonic



## Technical data

**Device overview, moulded case current transformer, class 0.5 ... / 5 A Secondary current\***

Type	Primary current in A	Power in VA	Primary conductor (bus bars)	Round conductor in mm	Width in mm	Weight (kg)	Item no.
IPA40.5	60	2	40 x 10; 30 x 15; 25 x 20	30	70	0.6	09.05.349
IPA40.5	75	2	40 x 10; 30 x 15; 25 x 20	30	70	0.6	09.05.350
IPA40.5	100	2.5	40 x 10; 30 x 15; 25 x 20	30	70	0.5	09.05.351
IPA40.5	150	5	40 x 10; 30 x 15; 25 x 20	30	70	0.6	09.05.236
6A315.3	200	3.75	30 x 15; 20 x 20	28	60	0.3	09.00.360
6A315.3	250	5	30 x 15; 20 x 20	28	60	0.3	09.00.361
6A315.3	300	5	30 x 15; 20 x 20	28	60	0.3	09.00.362
6A315.3	400	5	30 x 15; 20 x 20	28	60	0.3	09.00.363
6A315.3	500	5	30 x 15; 20 x 20	28	60	0.3	09.00.364
6A315.3	600	5	30 x 15; 20 x 20	28	60	0.3	09.00.365
7A412.3	800	5	40 x 12; 2 x 30 x 10	33	70	0.4	09.00.887
7A412.3	1,000	5	40 x 12; 2 x 30 x 10	33	70	0.4	09.00.888
8A512.3	1,250	5	50 x 12; 2 x 40 x 10	42	85	0.4	09.01.339
9A615.3	1,500	5	63 x 15; 2 x 50 x 10	53	95	0.5	09.01.820
9A615.3	1,600	5	63 x 15; 2 x 50 x 10	53	95	0.5	09.01.821
9A615.3	2,000	5	63 x 15; 2 x 50 x 10	53	95	0.5	09.01.822
9A615.3	2,500	5	63 x 15; 2 x 50 x 10	53	95	0.5	09.01.823

### Accessories

Mounting clip	for DIN rail EN 50022-35, suitable for 9A615.3, IPA40 style, 1 pair	0.01	09.09.000
Mounting clip	for DIN rail EN 50022-35, suitable for 6A315.3, 7A412.3, 8A512.3 and 9A615.3 style, 1 pair	0.01	09.09.001
Mounting clip	for DIN rail EN 50022-35, suitable for IPA40.5 style, 1 pair	0.01	09.09.002

\* Secondary current transformer ... / 1 A as well as other types on request.

# Moulded case current transformers class 1 ... / 5 A

**General properties, type ASK**

- Unbreakable plastic housing
- Polycarbonate black
- Flame retardant
- Self-extinguishing
- Transformer housing ultrasonically welded
- Nickel-plated secondary terminals with plus/minus M 5 x 8 mm screw, tightening torque max. 2 Nm
- Integrated secondary closure flap
- Connection cross section: max 4 mm<sup>2</sup> with wire end ferrule, 6 mm<sup>2</sup> solid

**General properties, type CTB**

- UL certified
- World's first current transformer with screwless connection technology – spring-loaded terminal block
- Innovative, time-saving connection option (front or top) for solid and flexible conductors (max. 4 mm<sup>2</sup> – wire end ferrules are not necessary)
- Shock and vibration resistant, high mechanical holding forces
- Maintenance-free, gas-tight connection
- High current resistance
- Therm. rated continuous current I<sub>cth</sub>: 1.2 x I<sub>N</sub>
- Low-voltage current transformer for max. operating voltages up to 1.2 kV; use in 690 V networks possible



## Technical data

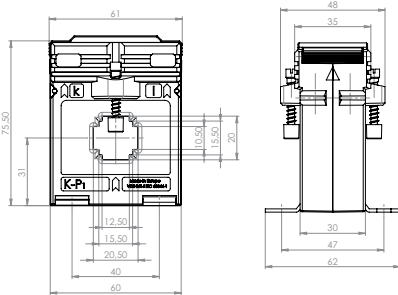
Device overview, moulded case current transformers class 1 ... / 5 A secondary current*							
Type	Primary current in A	Power in VA	Primary conductor	Round conductor in mm	Overall width in mm	Weight (kg)	Item no.
ASK 21.3	75	2.5	20 x 10	19.2	61	0.31	15.03.206
ASK 21.3	80	2.5	20 x 10	19.2	61	0.32	15.03.207
ASK 21.3	100	3.75	20 x 10	19.2	61	0.26	15.03.208
ASK 31.5	75	1.5	30 x 10; 20 x 10	28	61	0.45	15.03.270
CTB 31.35	100	2.5	30 x 10; 25 x 12; 20 x 20	25.7	60	0.23	15.03.272
CTB 31.35	150	2.5	30 x 10; 25 x 12; 20 x 20	25.7	60	0.23	15.03.273
CTB 31.35	200	2.5	30 x 10; 25 x 12; 20 x 20	25.7	60	0.23	15.03.274
CTB 31.35	250	5	30 x 10; 25 x 12; 20 x 20	25.7	60	0.23	15.03.275
CTB 31.35	300	5	30 x 10; 25 x 12; 20 x 20	25.7	60	0.23	15.03.276
CTB 31.35	400	5	30 x 10; 25 x 12; 20 x 20	25.7	60	0.23	15.03.277
CTB 31.35	500	5	30 x 10; 25 x 12; 20 x 20	25.7	60	0.23	15.03.278
ASK 31.3	600	5	30 x 10; 20 x 20	26	61	0.25	15.03.279
CTB 41.35	800	5	40 x 10; 30 x 15	31.8	70	0.30	15.03.280
CTB 41.35	1000	5	40 x 10; 30 x 15	31.8	70	0.30	15.03.281
CTB 51.35	1250	5	50 x 12; 40 x 30	43.7	85	0.35	15.03.282
CTB 61.35	1500	5	63 x 10; 50 x 30	43.7	95	0.35	15.03.283
CTB 81.35	1500	10	80 x 10; 60 x 30	54.7	120	0.35	15.03.284
CTB 81.35	1600	10	80 x 10; 60 x 30	54.7	120	0.35	15.03.285
CTB 81.35	2000	10	80 x 10; 60 x 30	54.7	120	0.38	15.03.286
CTB 101.35	2500	10	100 x 10; 80 x 30	70	130	0.40	15.03.287
Accessories							
Mounting clip for CTB design							15.02.140
Mounting clip for ASK 31.5 design							15.02.141
Mounting clip for ASK 31.3 design							15.02.151



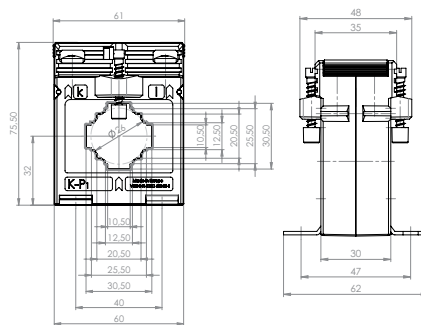
# Dimensional drawings

All specifications in mm

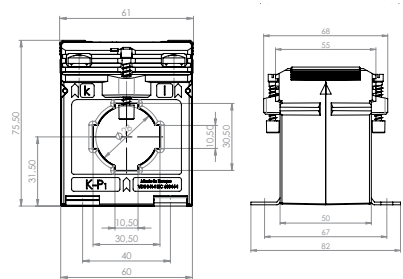
**ASK 21.3**



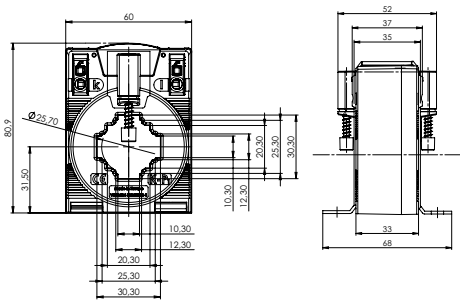
**ASK 31.3**



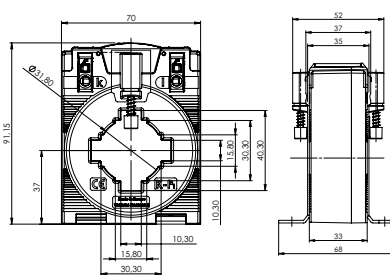
**ASK 31.5**



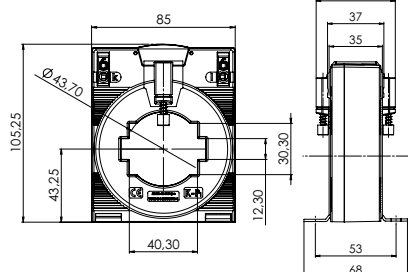
**CTB 31.35**



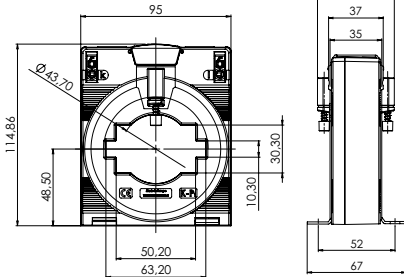
**CTB 41.35**



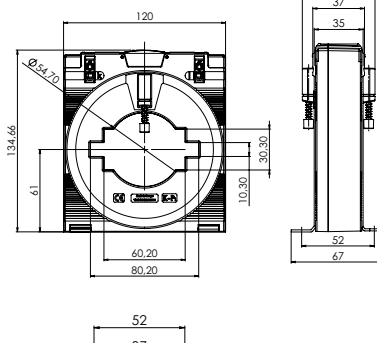
**CTB 51.35**



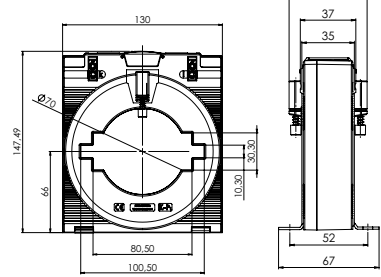
**CTB 61.35**



**CTB 81.35**



**CTB 101.35**



Basic information on the use of current transformers can be found in chapter 10.

# Moulded case current transformers for billing purposes class 0.5 ... / 5 A

### Increased safety

- Both halves of the housing overlap rather than butting up against one another
- Burst-resistant plastic housing made from polyamide
- Non-combustible per UL 94 VO and self-extinguishing

### Protective caps for primary rail fastening screws

- Screw-in pins for the primary rail terminals can be insulated by means of protective caps, available as an option
- Safeguard to prevent accidental contact

### Secondary connection feed

- Feeding of the secondary connection to the connection terminals through the rectangular opening in the front and rear sides
- During installation, e.g. behind the safety strip, the secondary connection is implemented by means of cable lugs through the side slots

### Expanded secondary terminal covering

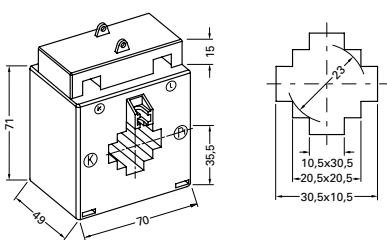
- In addition to the normal terminal covering, extra protective hoods are available
- Locking of the front and rear feed to the secondary terminals



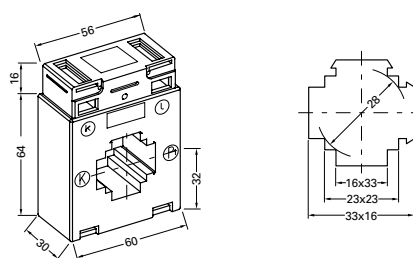
## Dimension diagrams

All dimensions in mm

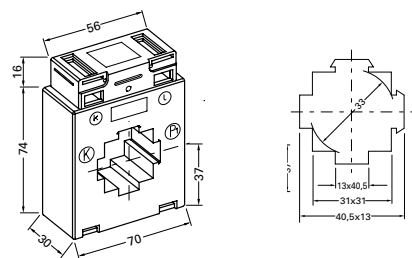
**EIPA30.5**



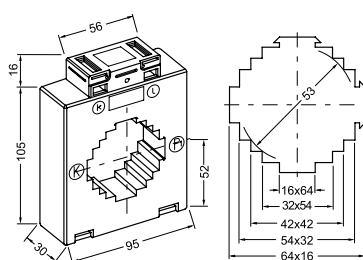
**E6A315.3**



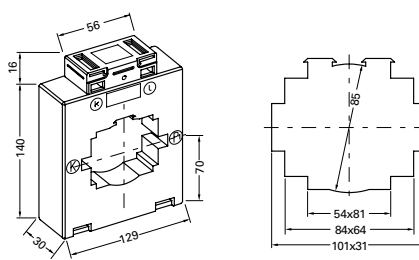
**E7A412.3**



**E9A615.3**



**E13A1030.3**





### General mechanical properties

- Nominal frequency 50 – 60 Hz
- Insulation class E (other classes on request)
- Thermal rated short-term current  $I_{th} = 60 \times I_N/1s$
- Rated surge current  $I_{dyn} = 2.5 \times I_{th}$ , however min. 100 kA with all plug-in current transformers
- Highest voltage for operating equipment  $U_m = 0.72$  kV
- Rated insulation level (test voltage) 4 kV / 1 min (per EN 61869-2)
- Over-current limit factor FS5 or FS10
- Harmonics current up to 50th harmonic



## Technical Data

Device overview, calibratable plug-in current transformer, class 0.5 ... / 5 A Secondary current*							
Type	Primary current in A	Power in VA	Primary conductor (bus bars)	Round conductor in mm	Width in mm	Weight (kg)	Item no.
EIPA30.5	50	2.5	30.5 x 10.5; 20.5 x 20.5; 10.5 x 30.5	23	70	0.4	09.14.813
EIPA30.5	75	2.5	30.5 x 10.5; 20.5 x 20.5; 10.5 x 30.5	23	70	0.4	09.14.812
EIPA30.5	100	2.5	30.5 x 10.5; 20.5 x 20.5; 10.5 x 30.5	23	70	0.3	09.14.811
E6A315.3	150	2.5	33 x 16; 23 x 23, 16 x 33	28	60	0.3	09.10.339
E6A315.3	200	2.5	33 x 16; 23 x 23, 16 x 33	28	60	0.3	09.10.340
E6A315.3	250	5	33 x 16; 23 x 23, 16 x 33	28	60	0.3	09.10.367
E6A315.3	300	5	33 x 16; 23 x 23, 16 x 33	28	60	0.3	09.10.366
E6A315.3	400	5	33 x 16; 23 x 23, 16 x 33	28	60	0.3	15.02.907
E6A315.3	500	5	33 x 16; 23 x 23, 16 x 33	28	60	0.3	09.10.364
E6A315.3	600	5	33 x 16; 23 x 23, 16 x 33	28	60	0.3	09.11.365
E7A412.3	750	5	40.5 x 13; 31 x 31, 13 x 40.5	33	70	0.3	09.10.391
E7A412.3	1.000	5	40.5 x 13; 31 x 31, 13 x 40.5	33	70	0.4	09.10.888
E9A615.3	1.500	5	64 x 16; 54 x 32; 42 x 42; 32 x 54; 16 x 64	53	95	0.4	09.10.387
E13A1030.3	2.000	5	101 x 31; 84 x 64; 54 x 81	85	129	0.5	09.12.888
E13A1030.3	2.500	5	101 x 31; 84 x 64; 54 x 81	85	129	0.5	09.12.889

Description	Item no.
Conformity declaration with corrigendum	09.50.011

\*These transformers are not on stock and will be ordered to customer order, products are excluded from return.  
Transformers with other primary or secondary currents on request.

Basic Information for the use of current transformer can be found in chapter 10.

# Moulded case current transformers for billing purposes Class 0,2S ... / 5 A

## Billing current transformer

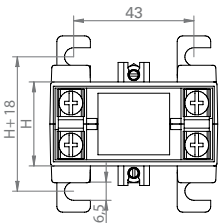
The current transformer for billing with a constantly sufficient load. In short, with which the valid regulations for kWh measurement devices are fulfilled. Each current transformer is individually measured and the test reports can be called up online. Flexibility, the compact design and safety are unique selling features of the line. All transformers are equipped with an integrated lockable terminal cover, produced from polycarbonate. The current transformers are supplied with a fastening tool, for mounting on rails, cables or assembly plates. The transformers can be optionally ordered with clips, which enable mounting on a DIN rail.



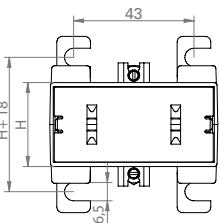
## Dimension diagrams

All dimensions in mm

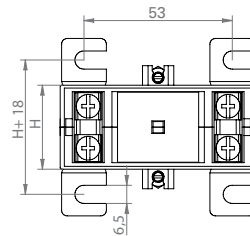
ERM60-E2A



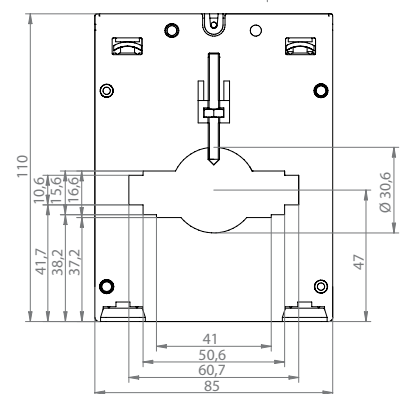
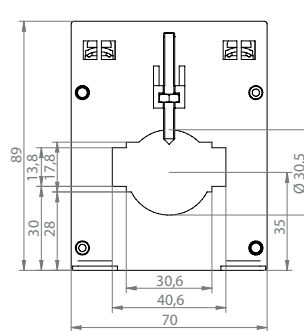
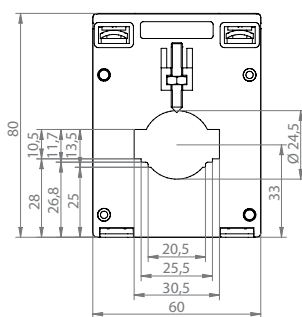
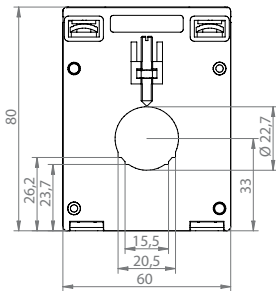
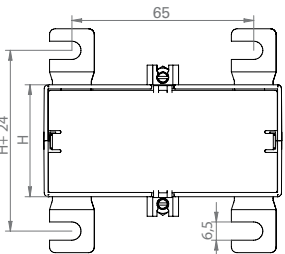
ERM60-E3A



ERM70-E4A



ERM85-E6A



### Dimensions

Type	H = Height in mm
ERM60..A, ERM70..A	30
ERM85..A	40
ERM70..B	50

### General properties

- Nominal frequency 50 – 60 Hz
- Insulation class E
- Thermal rated short-term current  $I_{th} = 60 \times I_N / 1s$
- Thermal continuous current  $1.2 \times I_N$
- Rated surge current  $I_{dyn} = 2.5 \times I_{th}$ , however min. 100 kA with all plug-in current transformers
- Highest voltage for operating equipment  $U_m = 0.72$  kV
- Rated insulation level (test voltage) 3 kV / 1 min (per IEC 61869-2)
- Over-current limit factor FS5 with max. power or FS10 with min. power
- Harmonics current up to 50th harmonic
- Test report available
- Temperature range -25 to 55°C
- Other current transformer requirements on request



## Technical data

### Device overview calibratable moulded case current transformer, class 0,2S / 5 A secondary current

Type	Primary current in A	Class	Power in VA	Transformation ratio	Primary conductor	Round conductor in mm	Width in mm	Weight (kg)	Item no.
ERM60-E3A	150	0.2S	1 VA	150/5 A	30 x 10	24,5	60	0,4	09.06.212
ERM60-E3A	200	0.2S	2 VA	200/5 A	30 x 10	24,5	60	0,4	09.06.213
ERM60-E3A	250	0.2S	2,5 VA	250/5 A	30 x 10	24,5	60	0,4	09.06.214
ERM70-E4A	300	0.2S	2,5 VA	300/5 A	40 x 10	30,5	70	0,4	09.06.215
ERM70-E4A	400	0.2S	5 VA	400/5 A	40 x 10	30,5	70	0,4	09.06.216
ERM70-E4A	500	0.2S	5 VA	500/5 A	40 x 10	30,5	70	0,4	09.06.217
ERM70-E4B	600	0.2S	5 VA	600/5 A	40 x 10	30,5	70	0,5	09.06.218
ERM70-E4B	750	0.2S	5 VA	750/5 A	40 x 10	30,5	70	0,5	09.06.219
ERM85-E6A	1000	0.2S	5 VA	1000/5 A	60 x 10	30,6	85	0,6	09.06.220

### Accessories

Mounting clips ERM60/ERM70	09.09.012
----------------------------	-----------

These transformers are not on stock and will be ordered to customer order, products are excluded from return.

Basic Information for the use of current transformer can be found in chapter 10.

## Low-power current transformers, class 0.5... / 0.1 A

### General properties, type ASK

- Unbreakable plastic housing
- Polycarbonate black
- Flame retardant
- Self-extinguishing
- Transformer housing ultrasonically welded
- Nickel-plated secondary terminals with plus/minus M 5 x 8 mm screw, tightening torque max. 2 Nm
- Integrated secondary closure flap
- Connection cross section: max 4 mm<sup>2</sup> with wire end ferrule, 6 mm<sup>2</sup> solid

### General properties, type CTB

- UL certified
- World's first current transformer with screwless connection technology - spring-loaded terminal block
- Innovative, time-saving connection option (front or top) for solid and flexible conductors (max. 4 mm<sup>2</sup> - wire end ferrules are not necessary)
- Shock and vibration resistant, high mechanical holding forces
- Maintenance-free, gas-tight connection
- High current resistance
- Therm. rated continuous current I<sub>cth</sub>: 1.2 x I<sub>N</sub>
- Low-voltage current transformer for max. operating voltages up to 1.2 kV; use in 690 V networks possible



## Technical data

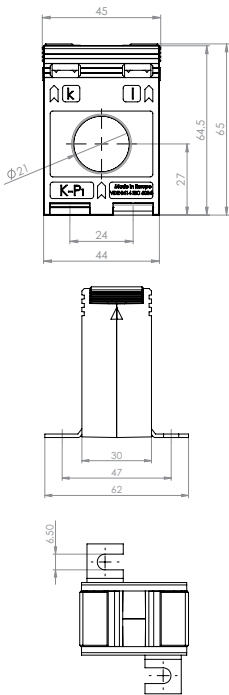
Device overview, low-power current transformers / class 0.5, 0.1 A secondary current								
Type	Primary current in A	Class	Power in VA	Primary conductor	Round conductor in mm	Overall width in mm	Weight (kg)	Item no.
ASR 20.3	150	0.5	1.5	-	21	45	0.30	15.03.200
ASK 41.4	250	0.5	1.5	40 x 10; 2 x 30 x 5	32	71	0.36	15.03.210
ASK 41.4	400	0.5	1.5	40 x 10; 2 x 30 x 5	32	71	0.40	15.03.215
CTB 31.35	150	0.5	1.5	30 x 10; 25 x 12; 20 x 20	25.7	60	0.40	15.03.220
CTB 41.35	250	0.5	1.5	40 x 10; 30 x 15	31.8	70	0.40	15.03.225
CTB 41.35	400	0.5	1.5	40 x 10; 30 x 15	31.8	70	0.40	15.03.230
Accessories								
Mounting clip for ASR 20.3								15.02.143
Mounting clip for ASK 41.4								15.02.142
Mounting clip for CTB								15.02.140
Individual accessory (load is included the scope of the transformer delivery)								
Load (0.8 Ω) for operating current transformers with 1.5 m connection cable and spring-loaded terminal block								15.03.085



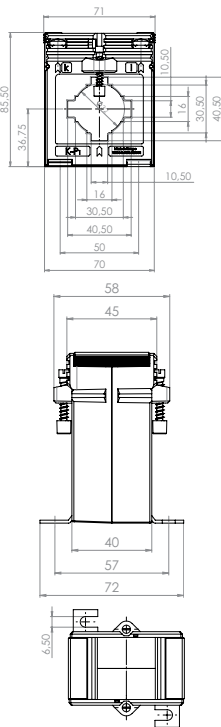
# Dimensional drawings

All specifications in mm

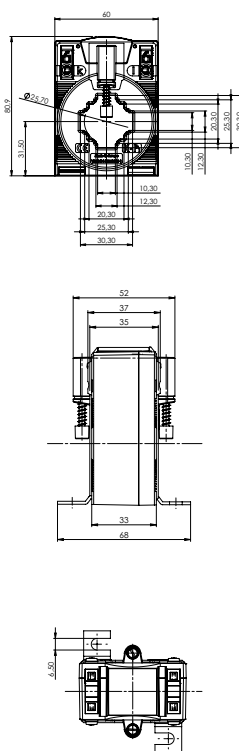
**ASR 20.3**



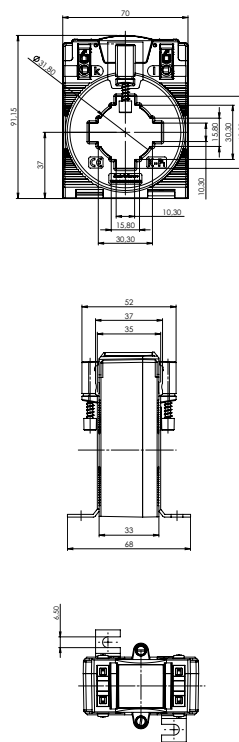
**ASK 41.4**



**CTB 31.35**



**CTB 41.35**



Basic information on the use of current transformers can be found in chapter 10.

# Summation current transformer, class 1 and 0.5 for feedthrough and split core

## Potential-free measurement

- Summation of the secondary currents from multiple main CTs
- Thus measuring of multiple feeders by just one meter
- Standardised measurement signal available at the output
- Alongside the addition of the input currents, the total is also divided by the number of inputs
- Distinction for similar and dissimilar main transformers



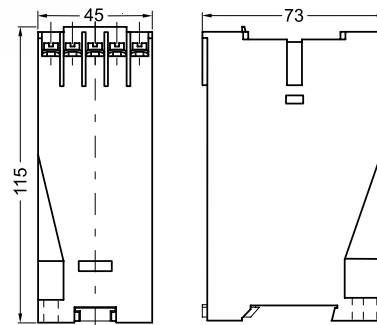
## General mechanical properties

- Break-proof plastic housing made from ABS, IP40
- Non-combustible per UL 94 VO, self-extinguishing
- Nickel-plated terminals with Plus-Minus screws
- Integrated electric shock protection, IP10
- Nominal frequency 50 – 60 Hz
- Insulation class E (other classes on request)
- Thermal rated short-term current  $I_{th} = 60 \times I_N/1s$
- Rated surge current  $I_{dyn} = 2.5 \times I_N$
- Maximum operating voltage  $U_m = 0.72 \text{ kV}^{*1}$
- Rated insulation level (test voltage)  $3 \text{ kV} / 1 \text{ min}^{*1}$
- Over-current limit factor FS5 or FS10
- Maximum conductor cross-section:  $2.5 \text{ } \varnothing$  solid,  $1.5 \text{ } \varnothing$  flexible



## Dimension diagrams

All dimensions in mm



## Technical data

Summation current transformer, class 1							
Type	Primary current in A	Secondary current in A	Power in VA	Transformation ratio	Dimensions in mm (W x H x D)	Weight (kg)	Item no.
IPS20	5+5	5	15	1:1	45 x 115 x 73	0.4	15.02.510
IPS30	5+5+5	5	15	1:1:1	45 x 115 x 73	0.4	15.02.515
IPS40	5+5+5+5	5	15	1:1:1:1	45 x 115 x 73	0.5	15.02.520
IPS20	1+1	1	15	1:1	45 x 115 x 73	0.5	09.05.306
IPS30	1+1+1	1	15	1:1:1	45 x 115 x 73	0.5	09.05.316
IPS40	1+1+1+1	1	15	1:1:1:1	45 x 115 x 73	0.5	09.05.326
IPS21	5+5	5	15	as required	45 x 115 x 73	0.4	15.02.526
IPS31	5+5+5	5	15	as required	45 x 115 x 73	0.4	15.02.521
IPS41	5+5+5+5	5	10	as required	45 x 115 x 73	0.5	15.02.525

Summation current transformer, class 0.5							
Type	Primary current in A	Secondary current in A	Power in VA	Transformation ratio	Dimensions in mm (W x H x D)	Weight (kg)	Item no.
IPS20	5+5	5	15	1:1	45 x 115 x 73	0.5	15.02.511
IPS30	5+5+5	5	15	1:1:1	45 x 115 x 73	0.5	15.02.516
IPS40	5+5+5+5	5	15	1:1:1:1	45 x 115 x 73	0.5	15.02.519

Not useable in combination with cable split core.  
 \*1 Other currents on request.

# Summation current transformer, class 1 for cable type split core current transformers

## No-compromise, individual measurement

- High measurement accuracy
- User friendly spring-clamp technology
- Designed for use with the series KUW split core CTs



## Technical data

Summation current transformer, class 1							
Type	Primary current in A	Secondary current in A	Power in VA	Transformer ratio	Dimensions in mm (W x H x D)	Weight (kg)	Item no.
STS20	1+1	1	0.2	1:1	30 x 80 x 60	0.2	15.02.560
STS30	1+1+1	1	0.2	1:1:1	30 x 80 x 60	0.2	15.02.561
STS40	1+1+1+1	1	0.2	1:1:1:1	55 x 80 x 60	0.4	15.02.562
STS50	1+1+1+1+1	1	0.2	1:1:1:1:1	55 x 80 x 60	0.4	15.02.563
STS60	1+1+1+1+1+1	1	0.2	1:1:1:1:1:1	55 x 80 x 60	0.4	15.02.564
STS21	1+1	1	0.2	Customer-specific	30 x 80 x 60	0.2	15.02.570
STS31	1+1+1	1	0.2	Customer-specific	30 x 80 x 60	0.2	15.02.571
STS41	1+1+1+1	1	0.2	Customer-specific	55 x 80 x 60	0.4	15.02.572
STS51	1+1+1+1+1	1	0.2	Customer-specific	55 x 80 x 60	0.4	15.02.573
STS61	1+1+1+1+1+1	1	0.2	Customer-specific	55 x 80 x 60	0.4	15.02.574

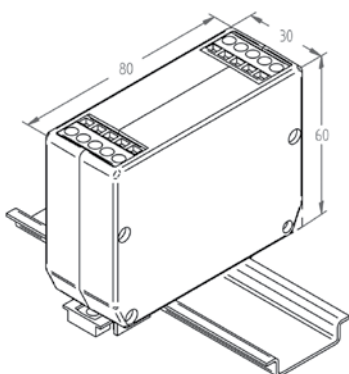
With dissimilar main CTs, the ratio of the largest to the smallest primary current should not be larger than 10/1.



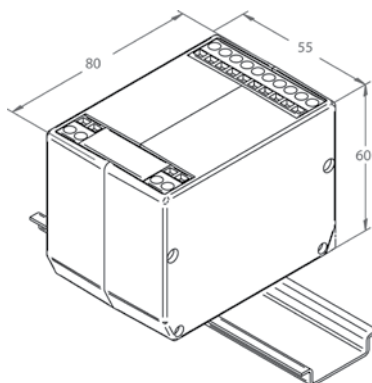
## Dimension diagrams

All dimensions in mm

STS20 / STS30 / STS21 / STS31



STS40 / STS50 / STS60 / STS41 / STS51 / STS61



Basic Information for the use of current transformer can be found in chapter 10.

# Cable split core current transformers

**Innovative and reliable**

- Particularly well suited to digital measurement devices
- Especially fast installation
- For applications with insulated cable up to 2 x 42 mm max.
- Transformation ratio of 60 ... 1000 / 1 A or 150 ... 1,000 / 5 A
- Including color-coded secondary cables
- Additional fastening of the transformer with the two UV-resistant cable ties provided
- Especially suited for retrofitting, primary circuit must not be disconnected
- Ideal for use in very compact installation spaces



Fig.: Type KUW4.2/60



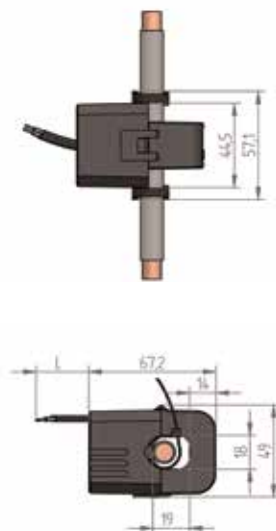
## Dimension diagrams

All dimensions in mm

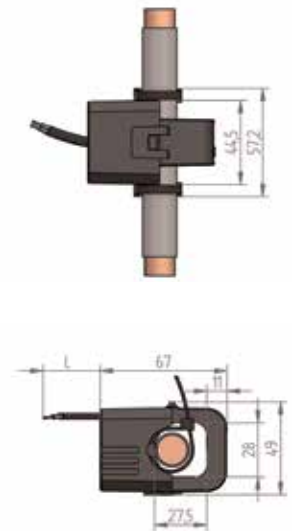
**KUW1/30**



**KUW1/40**



**KUW2/40**





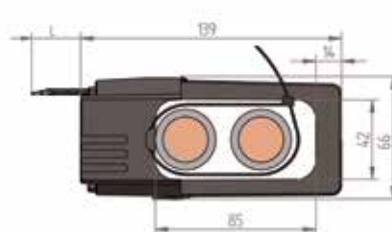
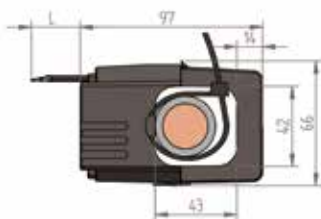
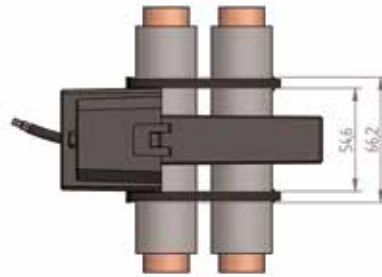
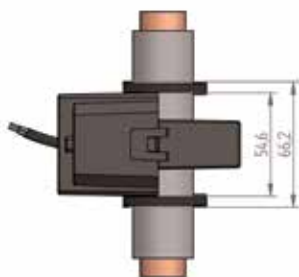


## Technical data

Environmental conditions	
Position of installation	For indoor usage, only for insulated cables
Ambient temperature	-10 ... +55 °C
Relative humidity	5 ... 85 % (no condensation)
Protection class	IP20
Application conditions	
Standard	IEC 61869-2
Thermal short time rated current	60 x I <sub>n</sub> / 1 s
Thermal continuous current	100 %
Rated isolation level	0.72 / 3 / kV
Rated frequency	50 / 60 Hz
Insulation class	E (120 °C)
Cable feed through window	For conductors max. Ø 18 / 28 / 42 or 2 x 42 mm
Secondary conductor	... / 1 A: 0.5 mm <sup>2</sup> ... / 5 A: 1.5 mm <sup>2</sup>

**KUW4/60**

**KUW4.2/60**



Basic Information for the use of current transformer can be found in chapter 10.

## Chapter 06

### Cable split core current transformers

Series KUW1 for insulated cable up to max. 18 mm diameter								
Type	Primary current in A	Secondary current in A	Power in VA (at the end of the wire)	Class	Cable length in m	Diameter Primary conductor in mm	Weight (kg)	Item no.
KUW1/30-60	60	1	0.2	3	3	18	0.3	15.03.510
KUW1/30-75	75	1	0.2	3	3	18	0.3	15.03.511
KUW1/30-100	100	1	0.2	3	3	18	0.3	15.03.512
KUW1/30-125	125	1	0.2	3	3	18	0.3	15.03.513
KUW1/30-150	150	1	0.2	3	3	18	0.3	15.03.514
KUW1/30-200	200	1	0.2	1	3	18	0.3	15.03.515
KUW1/30-250	250	1	0.2	1	3	18	0.3	15.03.317
KUW1/40-100	100	1	0.2	1	3	18	0.4	15.03.320
KUW1/40-125	125	1	0.2	1	3	18	0.4	15.03.321
KUW1/40-150	150	1	0.2	1	3	18	0.4	15.03.322
KUW1/40-200	200	1	0.2	0.5	3	18	0.4	15.03.325
KUW1/40-250	250	1	0.2	0.5	3	18	0.4	15.03.326
KUW1/40-150	150	5	1	1	0.5	18	0.4	15.03.329
KUW1/40-200	200	5	1	1	0.5	18	0.4	15.03.330
KUW1/40-250	250	5	1	0.5	0.5	18	0.4	15.03.331

Series KUW2 for insulated cable max. 28 mm diameter								
Type	Primary current in A	Secondary current in A	Power in VA (at the end of the wire)	Class	Cable length in m	Diameter Primary conductor in mm	Weight (kg)	Item no.
KUW2/40-200	200	1	0.2	1	3	28	0.3	15.03.351
KUW2/40-250	250	1	0.2	1	3	28	0.3	15.03.352
KUW2/40-300	300	1	0.2	1	3	28	0.3	15.03.354
KUW2/40-400	400	1	0.2	1	3	28	0.4	15.03.356
KUW2/40-500	500	1	0.2	0.5	3	28	0.4	15.03.358
KUW2/40-250	250	5	1	1	0.5	28	0.3	15.03.353
KUW2/40-300	300	5	1	1	0.5	28	0.3	15.03.355
KUW2/40-400	400	5	1	1	0.5	28	0.3	15.03.357
KUW2/40-500	500	5	1	1	0.5	28	0.3	15.03.359

Series KUW4/60 for insulated cable up to max. 42 mm diameter								
Type	Primary current in A	Secondary current in A	Power in VA (at the end of the wire)	Class	Cable length in m	Diameter Primary conductor in mm	Weight (kg)	Item no.
KUW4/60-250	250	1	0.5	1	5	42	0.6	15.03.565
KUW4/60-300	300	1	0.5	1	5	42	0.6	15.03.566
KUW4/60-400	400	1	0.5	0.5	5	42	0.6	15.03.568
KUW4/60-500	500	1	0.5	0.5	5	42	0.6	15.03.570
KUW4/60-600	600	1	0.5	0.5	5	42	0.6	15.03.572
KUW4/60-750	750	1	0.5	0.5	5	42	0.6	15.03.574
KUW4/60-800	800	1	0.5	0.5	5	42	0.6	15.03.576
KUW4/60-1000	1,000	1	0.5	0.5	5	42	0.6	15.03.578
KUW4/60-300	300	5	0.5	1	3	42	0.6	15.03.367
KUW4/60-400	400	5	0.5	1	3	42	0.5	15.03.369
KUW4/60-500	500	5	0.5	1	3	42	0.6	15.03.371
KUW4/60-600	600	5	0.5	0.5	3	42	0.5	15.03.373
KUW4/60-750	750	5	0.5	0.5	3	42	0.6	15.03.375
KUW4/60-800	800	5	0.5	0.5	3	42	0.6	15.03.377
KUW4/60-1000	1,000	5	0.5	0.5	3	42	0.6	15.03.379

Series KUW4.2/60 for insulated cable up to max. 2 x 42 mm diameter								
Type	Primary current in A	Secondary current in A	Power in VA (at the end of the wire)	Class	Cable length in m	Diameter Primary conductor in mm	Weight (kg)	Item no.
KUW4.2/60-250	250	1	0.5	1	5	42 x 84	0.7	15.03.580
KUW4.2/60-300	300	1	0.5	1	5	42 x 84	0.8	15.03.581
KUW4.2/60-400	400	1	0.5	0.5	5	42 x 84	0.7	15.03.583
KUW4.2/60-500	500	1	0.5	0.5	5	42 x 84	0.8	15.03.585
KUW4.2/60-600	600	1	0.5	0.5	5	42 x 84	0.7	15.03.587
KUW4.2/60-750	750	1	0.5	0.5	5	42 x 84	0.8	15.03.589
KUW4.2/60-800	800	1	0.5	0.5	5	42 x 84	0.8	15.03.591
KUW4.2/60-1000	1,000	1	0.5	0.5	5	42 x 84	0.8	15.03.593
KUW4.2/60-300	300	5	0.5	1	3	42 x 84	0.7	15.03.382
KUW4.2/60-400	400	5	0.5	1	3	42 x 84	0.8	15.03.384
KUW4.2/60-500	500	5	0.5	1	3	42 x 84	0.6	15.03.386
KUW4.2/60-600	600	5	0.5	0.5	3	42 x 84	0.7	15.03.388
KUW4.2/60-750	750	5	0.5	0.5	3	42 x 84	0.8	15.03.390
KUW4.2/60-800	800	5	0.5	0.5	3	42 x 84	0.8	15.03.392
KUW4.2/60-1000	1,000	5	0.5	0.5	3	42 x 84	0.8	15.03.394

# Cable split core current transformer, type KBU, class 0,5 and 1

## Features / benefits

- Ideal for retrospective installation in existing systems
- Simple and secure attachment - current transformer audibly latches
- Available with secondary current 5 A / 1 A
- Also available in accuracy class 0.5
- Four different configurations
- Working temperature range:  $-5^{\circ}\text{C} < T < +50^{\circ}\text{C}$
- Storage temperature range  $-25^{\circ}\text{C} < T < +70^{\circ}\text{C}$
- Therm. nominal continuous current  $I_{cth}$ :  $1,0 \times I_N$
- Therm. nominal short-time current  $I_{th}$ :  $60 \times I_N$ , 1 sec.
- Max. supply voltage  $U_m$ : 0,72 kV
- Insulation test voltage: 3 kV,  $U_{eff}$  50 Hz, 1 min.
- Nominal frequency: 50 Hz
- Insulation class: E
- Applied technical standards: DIN EN 61869, part 1 + 2



## Technical data

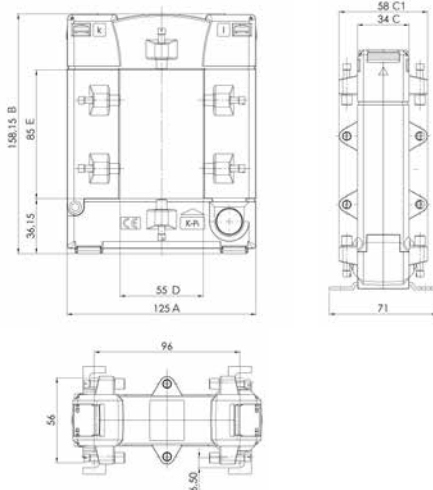
Cable split core current transformer, type KBU											
Type	Primary current in A	Secondary current in A	Power in VA	Class	Dimensions in mm					Weight (kg)	Item no.
					A	B	C / C1	D	E		
KBU 58	250	5	1.5	1	125	158	34 / 58	55	85	0.9	15.02.316
KBU 58	400	5	1	0.5	125	158	34 / 58	55	85	0.9	15.02.868
KBU 58	500	5	2.5	0.5	125	158	34 / 58	55	85	0.9	15.02.819
KBU 58	600	5	2.5	0.5	125	158	34 / 58	55	85	1.0	15.02.315
KBU 58	1000	5	5	0.5	125	158	34 / 58	55	85	1.0	15.02.320
KBU 812	600	5	2.5	0.5	155	198	34 / 58	85	125	1.3	15.02.869
KBU 812	800	5	2.5	0.5	155	198	34 / 58	85	125	1.3	15.02.870
KBU 812	1000	5	5	0.5	155	198	34 / 58	85	125	1.3	15.02.871
KBU 812	1250	5	7,5	0.5	155	198	34 / 58	85	125	1.3	15.02.328



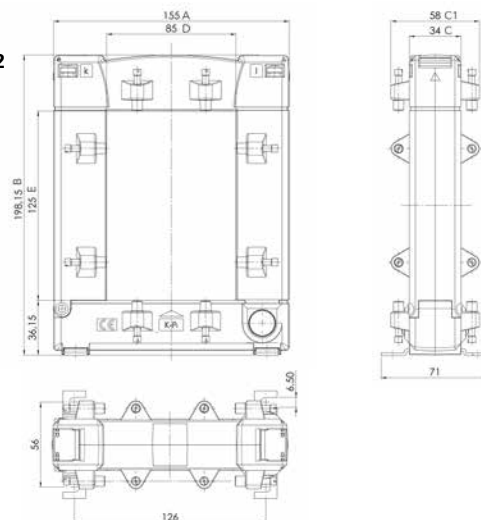
## Dimension diagrams

All dimensions in mm

KBU 58



KBU 812



# Three-phase current transformers type ASRD 14, class 0,5 and 1

## Three-phase current transformer with 5 A secondary current

- Primary current 100 A
- Secondary current 5 A
- Conductor feed-through  $\varnothing$  13.5 mm per phase
- For connection to current measuring systems with 5 A input



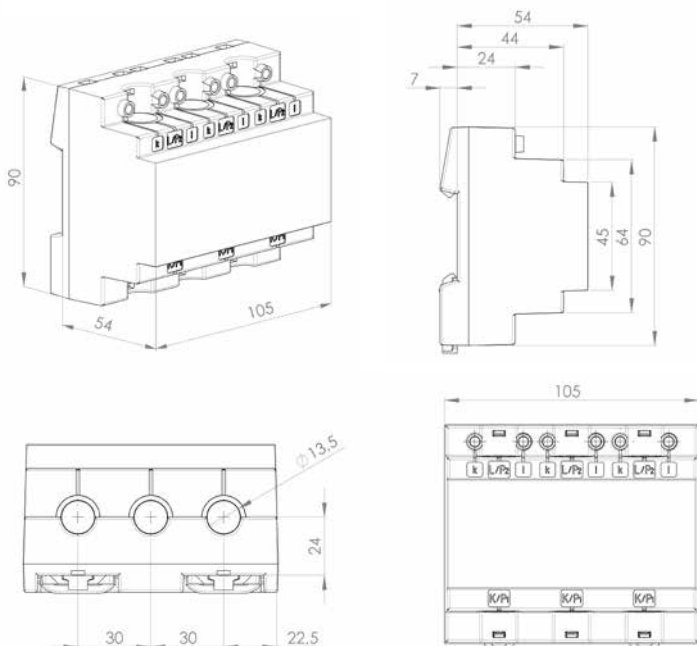
## Technical data

Three-phase current transformer type ASRD 14								
Type	Primary current in A	Secondary current in A	Power in VA	Class	Round conductor in mm	Dimensions in mm (W x H x D)	Weight (kg)	Item no.
ASRD 14	50	5	1	1	13.5	90 x 105 x 54	0.5	15.03.403
ASRD 14	75	5	1.5	1	13.5	90 x 105 x 54	0.5	15.03.404
ASRD 14	100	5	2.5	1	13.5	90 x 105 x 54	0.5	15.03.405
ASRD 14	125	5	2.5	0.5	13.5	90 x 105 x 54	0.5	15.03.406
ASRD 14	150	5	2.5	0.5	13.5	90 x 105 x 54	0.5	15.03.407



## Dimension diagrams

All dimensions in mm



# DIN rail current transformers with voltage tap and fuse, class 0,5 and 1

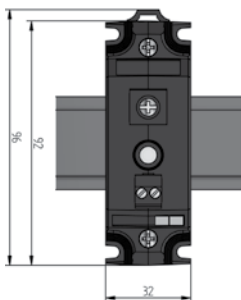
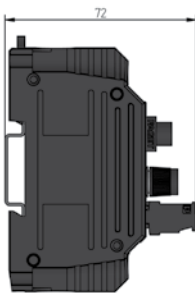
## Save time and space

- For precise current and voltage measurement
- Integrated current transformer and fuse protected voltage tap
- Prevention of connection errors
- Specially developed for energy measurement up to 64 A
- Transformation ratios 35/1 and 64/1 A
- With test mark from KEMA-KEUR



## Dimension diagrams

All dimensions in mm



## Technical data

Technical data	
<b>General</b>	
Maximum voltage	690 V, Uimp 6 kV
Insulation voltage	1890 V / 50 Hz 1 min
Rated current	35 / 64 A
Max. current (16 mm <sup>2</sup> )	42 / 76 A
Protection class	E (max. 120 °)
Protection class	IP20
Ambient temperature	-5 ... +40 °C
Housing	PA, 30 % glass proportion
Screw connection	cross head DIN 7962-H2
<b>Terminal</b>	
Standard	IEC 60947-7-1
Connection cross-section	1.5 mm <sup>2</sup> – 16 mm <sup>2</sup>
<b>Voltage tap-off</b>	
Short-circuit withstand capability	70 kA to 400 V / 50 Hz
Connection cross-section max.	4 mm <sup>2</sup>
Fuse type	5 x 25 mm (with notification) Max. 2 A SIBA DIN 41576-2
<b>Current transformers</b>	
Standard	IEC 61869-2
Maximum short term current	60 x In
Insulation voltage	3 kV / 50 Hz 1 min

### DIN rail current transformer overview

Type	Transformation ratio	Power in VA	Class	Dimensions in mm (W x H x D)	Weight (kg)	Item no.
CT 35/1A	35/1 A	0.2	1	32 x 72 x 96	0.2	15.03.002
CT 64/1A	64/1 A	0.2	0.5	32 x 72 x 96	0.2	15.03.003

Basic Information for the use of current transformer can be found in chapter 10.

# Compact current transformers CT27, class 1

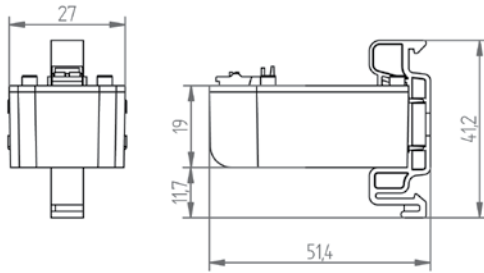
## Compact innovation

- Compact current transformer
- Particularly well suited to digital measurement devices
- Current transformer per IEC 61869-2
- Transformation ratios 35/1, 64/1 A, class 1
- Primary conductor feed-through window for insulated cable up to Ø 7.5 mm
- For use on a 3-phase circuit breaker with phase spacing of 17.5 mm
- DIN rail mounting (35 mm) via rail clamps (optional)
- Plug-in type CTs (Lego concept)



## Dimension diagrams

All dimensions in mm



## Technical data

Technical data	
<b>Environmental conditions</b>	
Position of installation	Indoor usage; only for insulated conductors
Ambient temperature	-10 ... +55 °C
Relative humidity	5 ... 85 % (no condensation)
Protection class	IP20
<b>Application conditions</b>	
Standard	IEC 61869-2
Thermal short time rated current	60 x I <sub>n</sub> / 1 s
Thermal continuous current	100 %
Rated isolation level	0.72 / 3 / kV
Rated frequency	50 / 60 Hz
Insulation class	E (120 °C)
Cable feed through window	Ø 7.5 mm
Secondary conductor (spring clamps)	Wire cross section: 0.2 ... 1.5 mm <sup>2</sup> ; rigid, flexible

Current transformer CT27 – Class 1							
Type	Primary current in A	Secondary current in A	Power in VA (at the terminal)	Max. diameter, primary conductor in mm	Dimensions in mm (W x H x D)	Weight (kg)	Item no.
CT27-35	35	1	0.2	7.5	27 x 46 x 23	0.05	<b>15.03.080</b>
CT27-64	64	1	0.2	7.5	27 x 46 x 23	0.04	<b>15.03.081</b>
<b>Accessories</b>							
Mounting clip	For DIN rail EN 50022-35, suitable for CT27-35 and CT27-64				41 x 14 x 27	0.001	<b>09.09.010</b>

## Split-core current transformer SC-CT-20, class 1

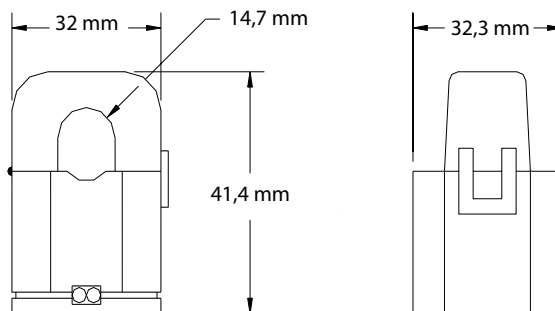
### Innovative and flexible

- Compact, divisible, split-core current transformer
- Separable current transformer up to max. 63 A especially for retrofitting
- Transformation ratio 3,000/1
- Primary window can be used for insulated cable up to  $\varnothing$  10 mm
- Special version for the UMG 20CM branch circuit monitoring device



### Dimension diagrams

All dimensions in mm



### Technical data

Environmental conditions	
Position of installation	Indoor usage; only for insulated conductors
Ambient temperature	-10 ... +55 °C
Protection class	IP20
Application conditions	
Measuring accuracy	1 %
Thermal continuous current	100 %
Insulation resistance	100 MOhm
Rated frequency	50 / 60 Hz
Max. frequency	20 – 1000 Hz
Secondary conductor	Wire cross section: 0.75 mm <sup>2</sup> Rigid, flexible

Split-core current transformer SC-CT-20								
Type	Max. operating current (A)	Transformation ratio	Max. primary conductor diameter in mm	Class	Class	Dimensions in mm (W x H x D)	Weight (kg)	Item no.
SC-CT-20*	63	3,000/1	10	1	1	32 x 41.4 x 32.3	0.04	15.03.092
Individual accessory (load is included the scope of the SC-CT-20 delivery)								
Burden (3.9 Ω) for operating current monitoring with the SC-CT-20 with 1.5 m ready-made connection cable and spring type terminal adapter								15.03.086

\* Incl. ready-made connection cable; 1.5 m with burden and spring type terminal adapter for operating current measurement

Basic Information for the use of current transformer can be found in chapter 10.

# Split-core operating current transformers up to 600 A

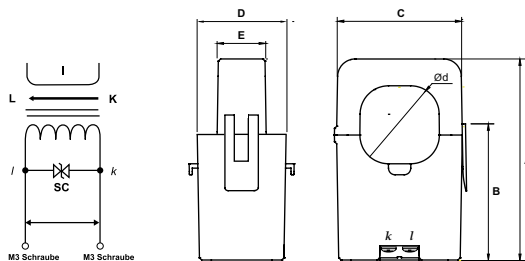
## Fast installation – reliable measurement

- Snap-in technology make installation in existing equipment easier
- Secure latching in place
- High number of secondary windings
- Small size, low weight
- Suitable for UMG 20CM



## Dimension diagrams

All dimensions in mm



## Technical data

Technical data						
Type	SC-CT-20-100	SC-CT-20-200	SC-CT-20-300	SC-CT-20-400	SC-CT-20-500	SC-CT-20-600
Current ratio	120 A / 40 mA	200 A / 66,6 mA	300 A / 100 mA	400 A / 100 mA	500 A / 100 mA	600 A / 100 mA
Current range (50/60 Hz)	0,01 ... 100 A (RL = 10 Ohm)	0,01 ... 200 A (RL = 10 Ohm)	0,1 ... 300 A (RL = 10 Ohm)	0,01 ... 400 A (RL = 5 Ohm)	0,01 ... 500 A (RL = 5 Ohm)	0,01 ... 600 A (RL = 5 Ohm)
Position of installation	Indoor usage (any mounting position)					
Ambient temperature	-20 ... +50 °C			-20 ... +55 °C		
Storage temperature	-30 ... +90 °C, rel. humidity <85 % (no condensation)					

Split core operating current transformer up to 600 A												
Type	Operating mode	Max. operating current in A	Transformation ratio	Max. primary conductor diameter in mm	Class	Dimensions in mm					Weight (kg)	Item no.
						A	B	C	D	E		
SC-CT-20-100	Operating current measurement* <sup>1</sup>	100	3000/1	16	1	55	41	29.5	31	19	ca. 0.075	15.03.093
SC-CT-20-200	Operating current measurement* <sup>1</sup>	200	3000/1	24	1	74.5	52	45	34	22	ca. 0.2	15.03.094
SC-CT-20-300	Operating current measurement* <sup>1</sup>	300	3000/1	24	1	74.5	52	45	34	22	ca. 0.2	15.03.095
SC-CT-20-400	Operating current measurement* <sup>1</sup>	400	4000/1	36	0.5	91.4	57.0	57.1	40.2	21.1	ca. 0.3	15.03.097
SC-CT-20-500	Operating current measurement* <sup>1</sup>	500	5000/1	36	0.5	91.4	57.0	57.1	40.2	21.1	ca. 0.3	15.03.099
SC-CT-20-600	Operating current measurement* <sup>1</sup>	600	6000/1	36	0.5	91.4	57.0	57.1	40.2	21.1	ca. 0.3	15.03.101

Single accessory (burden is included the scope of the transformer delivery)		
Burden (2.2 Ω) for operating current transformer SC-CT-20-100 with 1.5 m ready-made connection cable and spring type terminal adapter		15.03.087
Burden (1.1 Ω) for operating current transformer SC-CT-20-200 with 1.5 m ready-made connection cable and spring type terminal adapter		15.03.088
Burden (0.8 Ω) for operating current transformer SC-CT-20-300/400/500/600 with 1.5 m ready-made connection cable and spring type terminal adapter		15.03.085

\*<sup>1</sup> Incl. ready-made connection cable; 1.5 m with burden and spring type terminal adapter for operating current measurement



# Flexible current transformers

## Rogowski coil – thinner, lighter flex converter for simple installation

The Rogowski coil is used for current measurement of AC currents and is primarily employed for retrospective installation in existing systems - optionally on power rails or power cables.



- Frequency bandwidth 50/60 Hz, up to 700 kHz without load (no-load operation)
- Accuracy per class 0.5, in accordance with IEC 61869
- Operating temperature  $-40^{\circ}\text{C}$  bis  $+80^{\circ}\text{C}$
- Rated insulation voltage 1 kV CAT III
- Rogowski coil from 10 to 10000  $A_{\text{RMS}}$  – in combination with Janitza measurement transducer RogoTrans up to 4000  $A_{\text{RMS}}$
- Sealing possible
- CE certified (2014/30/EU), in accordance with the European Directive 2014/35/EU and tested in accordance with the standard IEC 61010-1
- Retrospective clip-on system without disconnecting the phase conductor
- Device for fixing to the primary conductor with a cable tie
- Internal screening
- High linearity, no saturation, no current upper limit of the Rogowski coil

Description	Item no.	Diameter	Length	Weight
Rogowski current transformer $\varnothing$ 70 mm	15.03.609	70 mm	3 m	192 g
Rogowski current transformer $\varnothing$ 175 mm	15.03.610	175 mm	3 m	206 g
Rogowski current transformer $\varnothing$ 300 mm	15.03.611	300 mm	3 m	222 g

**Note: in order to ensure smooth operation of the Rogowski coils, a combination of the coil and the Janitza measurement transducer "RogoTrans" (15.03.613) is always necessary! Additionally a 24 V DC power supply is needed.**

Technical data			
Item no.	15.03.609	15.03.610	15.03.611
Max. output voltage	30 V	30 V	30 V
Primary current <sup>*1</sup>	up to 10000 A <sup>*1</sup>	up to 10000 A <sup>*1</sup>	up to 10000 A <sup>*1</sup>
Rated transformation ratio (@ 50 Hz)	44,44 kA/V	44,44 kA/V	44,44 kA/V
Rated frequency	50/60 Hz	50/60 Hz	50/60 Hz
Secondary voltage	22,5 mV (at 1000 A / 50 Hz)	22,5 mV (at 1000 A / 50 Hz)	22,5 mV (at 1000 A / 50 Hz)
Mutual inductance	71,98 nH	72,314 nH	72,84 nH
Temperature coefficient of M	$\pm 30$ ppm/K	$\pm 30$ ppm/K	$\pm 30$ ppm/K
Frequency bandwidth (cable length 1,5 m) <sup>*2</sup>	420 kHz <sup>*2</sup>	350 kHz <sup>*2</sup>	300 kHz <sup>*2</sup>
Phase displacement	0,004 <sup>*3</sup>	0,004 <sup>*3</sup>	0,004 <sup>*3</sup>
Coil inductance	180 $\mu\text{H}$	343 $\mu\text{H}$	566 $\mu\text{H}$
Coil resistance	56 $\Omega$	105 $\Omega$	170 $\Omega$
Ratio error (centred)	- 0,5 ... 0,5 % class 0,5 Accuracy per IEC 61869-2	- 0,5 ... 0,5 % class 0,5 Accuracy per IEC 61869-2	- 0,5 ... 0,5 % class 0,5 Accuracy per IEC 61869-2
Ration error (all positions) <sup>*4</sup>	- 0,75 ... 0,75 <sup>*4</sup> incl. positioning errors	- 0,75 ... 0,75 <sup>*4</sup> incl. positioning errors	- 0,75 ... 0,75 <sup>*4</sup> incl. positioning errors
Linearity error	none	none	none
Influence of external current <sup>*5</sup>	$\pm 0,2$ <sup>*5</sup>	$\pm 0,2$ <sup>*5</sup>	$\pm 0,2$ <sup>*5</sup>

\*1 In combination with Janitza measurement transducer RogoTrans up to 4000 A.

\*2 On request, the frequency bandwidth and phase shifting model can be made available.

\*3 With installation at a right angle to the phase conductor.

\*4 Under consideration that the Janitza Rogowski current transformer is installed perpendicular to a primary conductor of min.  $\varnothing$  15 mm.

\*5 Under consideration that a further phase conductor of min.  $\varnothing$  15 mm is installed at the same height and at a right angle to the Janitza Rogowski current transformer.

Basic Information for the use of current transformer can be found in chapter 10.

# Measurement transducer

## Measurement transducer for Rogowski current transformer

The measurement transducer “RogoTrans” for the Rogowski current transformer measures alternating currents and possesses a standardised output signal of 0 to 1 A.

- Compact construction in a plast housing
- Assembly on DIN rail possible
- Metering range up to 4000 A
- Voltage supply 24 V DC



Technical data	
Item no.	15.03.613
Dimesions	22.5 x 100 x 110 mm (W x H x D)
Weight	approx. 0.2 kg
Power supply	24 V DC (18 to 36V) / 1 A
Current draw	< 300 mA (with 1 A output current) < 80 mA (without output current)
Input	Janitza Rogowski coil max. 90 mV (4000 A range)
Current metering ranges	1 to 4000 A 1 to 2000 A 1 to 1000 A 1 to 500 A 1 to 250 A
Metering range setting (button) LED (yellow)	Wear-free metering range selection via micro-controller and PGA
Operating and metering range display	via 6 LED (green)
Phase angle	< 1°
Linearity error at 50 Hz Measuring error at 50 Hz	< 0.2% in all metering ranges < 0.2% in all metering ranges
Input impedance	10 k Ω in all metering ranges
Signal output	0 to 1 A
Measurement range exceeding	110%
Burden	0 to 1.5 Ohm
Linearity error burden 0 to 1.5 Ohm	< 0,02%
Alarm output	24 V DC / 200 mA (floating potential optical output, open with fault)
Alarm messages (via red LED)	Overload (range exceeding) Burden too great (output circuit) Undervoltage (24 V)
Alarm delay	60 seconds
Protection type	IP30
Ambient temperature	-20°C to +70°C
Installation position	Vertical; if multiple devices are used next to each other then a minimum distance of 5 mm must be maintained between the devices (heat development)
Storage temperature	-25°C to +85°C

The combination of the coil and the measurement transducer is not compatible with the UMG 20CM.

Basic Information for the use of current transformer can be found in chapter 10.

# RESIDUAL CURRENT TRANSFORMERS



## Chapter 06

### Compatibility residual current transformer

RCM transformer type	Item number	Window size	Split core Yes/No	Residual current type	Current transformer ratio
DACT20	15.03.201	20 mm round	No	Type A (Type B with RCM 202-AB)	600/1
CT-AC RCM 35N	15.03.458	35 mm round	No	Type A (Type B with RCM 202-AB)	700/1
CT-AC RCM 80N	15.03.459	80 mm round	No	Type A (Type B with RCM 202-AB)	700/1
CT-AC RCM 110N	15.03.463	110 mm round	No	Type A (Type B with RCM 202-AB)	700/1
CT-AC RCM 140N	15.03.460	140 mm round	No	Type A (Type B with RCM 202-AB)	700/1
CT-AC RCM 210N	15.03.464	210 mm round	No	Type A (Type B with RCM 202-AB)	700/1
CT-20	15.03.082	7,5 mm round	No	Type A	700/1
SC-CT-21	15.03.084	8,5 mm round	Yes	Type A	700/1
CT-AC RCM A110N	15.03.462	110 mm round	Yes	Type A (Type B with RCM 202-AB)	700/1
CT-AC RCM A150N	15.03.465	150 mm round	Yes	Type A (Type B with RCM 202-AB)	700/1
CT-AC RCM A310N	15.03.461	310 mm round	Yes	Type A (Type B with RCM 202-AB)	700/1
KBU 23D	15.03.400	20 mm x 30 mm square	Yes	Type A (Type B with RCM 202-AB)	600/1
KBU 58D	15.03.401	50 mm x 80 mm square	Yes	Type A (Type B with RCM 202-AB)	600/1
KBU 812D	15.03.402	80 mm x 120 mm square	Yes	Type A (Type B with RCM 202-AB)	600/1
CT-AC/DC Typ B+ 35 RCM	15.03.469	35 mm round	No	Type B+ (AC and DC)	4–20 mA (300 mA/5 A)
CT-AC/DC Typ B+ 70 RCM	15.03.468	70 mm round	No	Type B+ (AC and DC)	4–20 mA (300 mA/5 A)

	Primary current with UMG 96RM-E, UMG 509-PRO, UMG 512-PRO, UMG 96RM-PN Module 96-PA-RCM Module 96-PA-RCM-EL	Primary current with UMG 20CM	Primary current with RCM 202-AB	Compatibility UMG 96RM-E, UMG 509-PRO, UMG 512-PRO, UMG 96RM-PN Module 96-PA-RCM Module 96-PA-RCM-EL	Compatibility RCM 202-AB	Compatibility UMG 20CM
	18000 mA	1000 mA without burden 16000 mA with burden	20 A AC / 20 A DC	Yes	Yes	Yes
	21000 mA	1000 mA without burden 16000 mA with burden	20 A AC / 20 A DC	Yes	Yes	Yes
	21000 mA	1000 mA without burden 16000 mA with burden	20 A AC / 20 A DC	Yes	Yes	Yes
	21000 mA	1000 mA without burden 16000 mA with burden	20 A AC / 20 A DC	Yes	Yes	Yes
	21000 mA	1000 mA without burden 16000 mA with burden	20 A AC / 20 A DC	Yes	Yes	Yes
	21000 mA	1000 mA without burden 16000 mA with burden	20 A AC / 20 A DC	Yes	Yes	Yes
	21000 mA	1000 mA without burden 16000 mA with burden	not compatible	Yes	not compatible	Yes
	21000 mA	1000 mA without burden 16000 mA with burden	not compatible	Yes	not compatible	Yes
	21000 mA	1000 mA without burden 16000 mA with burden	20 A AC / 20 A DC	Yes	Yes	Yes
	21000 mA	1000 mA without burden 16000 mA with burden	20 A AC / 20 A DC	Yes	Yes	Yes
	21000 mA	1000 mA without burden 16000 mA with burden	20 A AC / 20 A DC	Yes	Yes	Yes
	18000 mA	1000 mA without burden 16000 mA with burden	20 A AC / 20 A DC	Yes	Yes	Yes
	18000 mA	1000 mA without burden 16000 mA with burden	20 A AC / 20 A DC	Yes	Yes	Yes
	18000 mA	1000 mA without burden 16000 mA with burden	20 A AC / 20 A DC	Yes	Yes	Yes
	300 mA	not compatible	not compatible	only UMG 96RM-E, Module 96-PA-RCM, Module 96-PA-RCM-EL	not compatible	not compatible
	300 mA	not compatible	not compatible	only UMG 96RM-E, Module 96-PA-RCM, Module 96-PA-RCM-EL	not compatible	not compatible

# Split-core residual current transformers

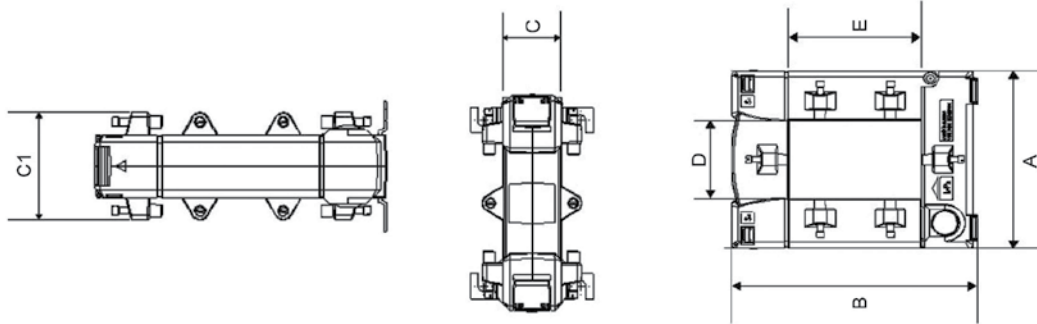
## Handy and compact

- Simple and economical installation, especially for retrofit
- Practical locking system: Separating of primary cable not required
- Available in various different sizes
- No interruption of operations
- Suitable for UMG 96RM-E, UMG 96RM-PN, UMG 20CM, UMG 509-PRO and UMG 512-PRO



## Dimension diagrams

All dimensions in mm



## Technical data

Technical data	
General	
Construction style	Conductor low voltage residual current transformer
Housing material	Polycarbonate, grey RAL 7035
Max. voltage for electrical equipment	Um <= 0.72 kV
Insulation test voltage	3 kV Ueff.; 50 Hz; 1 min
Rated frequency	50 Hz
Secondary connection	Brass profile, nickel plated, max. 4.0 mm <sup>2</sup>
Nominal ratio Ipn / Isn	10 / 0.0167 A
Working frequency range	30 ... 1000 Hz
Secondary rated apparent power	0.05 VA
Ambient temperature range	-5 ... +45 °C
Max. temperature of the primary conductor	90 °C

### Advice:

In case that the residual current converters of series KBU are used in connection with UMG 20CM, the measuring range of UMG 20CM can be raised from 900 mA or 1 A to 14 A or 15 A by use of a burden with item no. 15.03.086.

Differential current transformer type A											
Type	Transformation ratio	Max. primary residual current in mA <sup>1</sup>	Max. wire diameter in mm	Busbar in mm	Dimensions in mm					Weight (kg)	Item no.
					A	B	C / C1	D	E		
KBU 23D <sup>2</sup>	600/1	18000	4 x approx. 10 (rm-10 qmm) or 8 x 7 (rm-6 qmm)	max. 20 x 30	93	106	34/58	20	30	0.7	15.03.400
KBU 58D <sup>2</sup>	600/1	18000	4 x approx. 27 (rm-240 qmm) or 8 x 20 (rm-95 qmm)	max. 50 x 80	125	158	34/58	50	80	1.1	15.03.401
KBU 812D <sup>2</sup>	600/1	18000	4 x approx. 42 (rm-500 qmm) or 8 x 29 (rm-240 qmm)	max. 80 x 120	155	198	34/58	85	125	1.4	15.03.402
Accessories											
Burden (3,9 Ω) with 1.5 m ready-made connection cable and spring type terminal adapter										15.03.086	

<sup>1</sup> When using the analogue inputs of the UMG 96RM-E, UMG 96RM-PN, UMG 509-PRO and UMG 512-PRO.

<sup>2</sup> If the Differential current transformer of the series KBU is in use with the UMG 20CM, the measuring range of the UMG 20CM can be stepped up also higher from 900 mA to 14 A and from 1 to 15 A by integrating a burden, item no. 15.03.086.

# Split-core residual current transformers

## Main features

- Makes it possible, in conjunction with the UMG devices, to determine the residual current to earth of machines or systems
- Compact construction
- Detection of very small currents
- Designed to increase the sensitivity of residual current breakers (personal protection) and general circuit breakers
- Suitable for the UMG 96 RM-E, UMG 96RM-PN, UMG 509-PRO, UMG 512-PRO, UMG 20CM



## Technical data

General data	
Insulation voltage	0,72 kV
Frequency	3 kHz
Operating temperature	-10 to +55 °C
Test voltage	3 kV RMS 50 Hz / 1 min.

Device overview – Plug-in residual current transformer type A					
Type	Transformation ratio	Max. primary residual current in mA*	Max. wire diameter in mm	Busbar in mm	Item no.
CT-AC RCM A110N	700/1	21000	4 x approx. 44 (rm–500 qmm) or 8 x 33 (rm–300 qmm)	max. 100 x 20	15.03.462
CT-AC RCM A150N	700/1	21000	4 x approx. 60 (rm–500 qmm) or 8 x 44 (rm–500 qmm)	max. 147 x 20	15.03.465
CT-AC RCM A310N	700/1	21000	4 x approx. 124 (rm–500 qmm) or 8 x 92 (rm–500 qmm)	max. 200 x 20	15.03.461

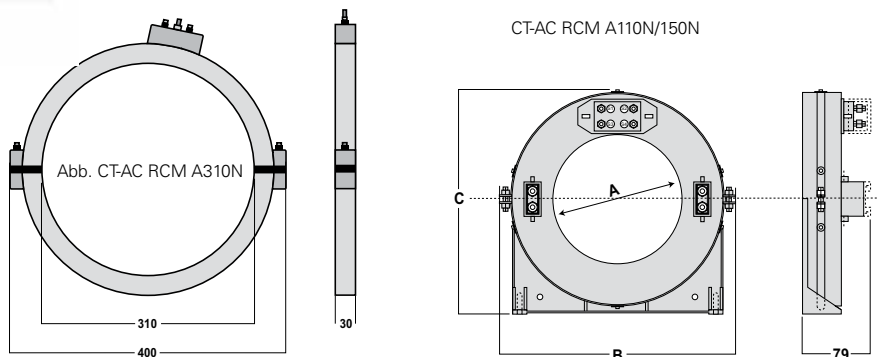
**Advice:**  
In case that the residual current converters of series CT-AC are used in connection with UMG 20CM, the measuring range of UMG 20CM can be raised from 900 mA or 1 A to 14 A or 15 A by use of a burden with item no. 15.03.086.

\* When using the analogue inputs of the UMG 96RM-E, UMG 96RM-PN, UMG 509-PRO and UMG 512-PRO.



## Dimension diagrams

All dimensions in mm



Dimensions - Plug-in residual current transformer type A				
Type	Dimensions in mm			Weight (kg)
	A	B	C	
CT-AC RCM A110N	110	235	219	2,35
CT-AC RCM A150N	150	275	259	2,50
CT-AC RCM A310N	310	400	416	3,80

Basic Information for the use of current transformer can be found in chapter 10.

# Feadthrough residual current transformers

## Main features

- Makes it possible, in conjunction with the UMG devices, to determine the residual current to earth of machines or systems
- Compact construction
- Detection of very small currents
- Designed to increase the sensitivity of residual current breakers (personal protection) and general circuit breakers
- Suitable for the UMG 96 RM-E, UMG 96RM-PN, UMG 20CM, UMG 509-PRO, UMG 512-PRO



## Technical data

General data	
Insulation voltage	0,72 kV
Frequency	3 kHz
Operating temperature	-10 to +55 °C
Test voltage	3 kV RMS 50 Hz / 1 min.

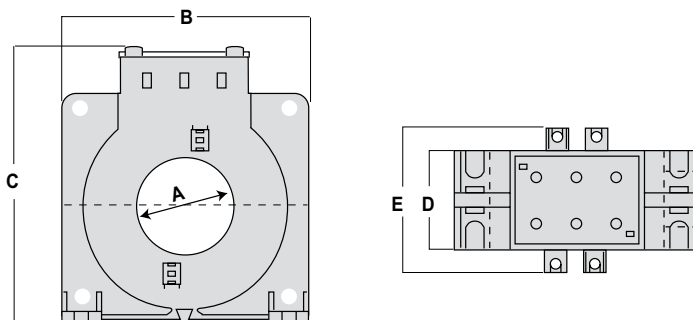
Device overview - Plug-in residual current transformer type A					
Type	Transformation ratio	Max. primary residual current in mA*	Max. wire diameter in mm	Busbar in mm	Item no.
CT-AC RCM 35N	700/1	21000	4 x approx. 14 (rm-35 qmm) or 8 x 10 (rm-10 qmm)	max. 30 x 10	15.03.458
CT-AC RCM 80N	700/1	21000	4 x approx. 32 (rm-300 qmm) or 8 x 24 (rm-150 qmm)	max. 60 x 20	15.03.459
CT-AC RCM 110N	700/1	21000	4 x approx. 44 (rm-500 qmm) or 8 x 33 (rm-300 qmm)	max. 100 x 20	15.03.463
CT-AC RCM 140N	700/1	21000	4 x approx. 56 (rm-500 qmm) or 8 x 42 (rm-300 qmm)	max. 120 x 20	15.03.460
CT-AC RCM 210N	700/1	21000	4 x approx. 85 (rm-500 qmm) or 8 x 62 (rm-500 qmm)	max. 200 x 20	15.03.464

\* When using the analogue inputs of the UMG 96RM-E, UMG 96RM-PN, UMG 509-PRO, UMG 512-PRO, Module 96-PA-RCM-EL and Module 96-PA-RCM



## Dimension diagrams

All dimensions in mm



Dimensions - Plug-in residual current transformer type A						
Type	Dimensions in mm					Weight (kg)
	A	B	C	D	E	
CT-AC RCM 35N	35	92	113	36	56	0,25
CT-AC RCM 80N	80	125	160	36	56	0,40
CT-AC RCM 110N	110	165	198	36	56	0,56
CT-AC RCM 140N	140	200	234	36	56	0,75
CT-AC RCM 210N	210	290	323	44	64	1,28

### Advice:

In case that the residual current converters of series CT-AC are used in connection with UMG 20CM, the measuring range of UMG 20CM can be raised from 900 mA or 1 A to 14 A or 15 A by use of a burden with item no. 15.03.086.



# Residual current transformer type A

## Main features

- For residual current detection in 3/4-phase alternating current networks
- Highly sensitive current sensor for detecting even the smallest fault currents
- Simple connection via 4-pin spring-loaded terminal
- High safety thanks to integrated overvoltage protection
- Flexible use due to a wide frequency range
- Operating temperature range:  $-10^{\circ}\text{C}$  to  $+70^{\circ}\text{C}$
- Storage temperature range:  $-25^{\circ}\text{C}$  to  $+70^{\circ}\text{C}$
- Thermal rated continuous differential current  $I_{\text{cth}}$
- Rated voltage: 800 V
- Measurement voltage surge: 8 kV
- Pollution degree: III
- Protection class: Housing: IP 40; terminals: IP 20
- Working frequency range: 30 Hz to 3 kHz
- Applied harmonized standards: IEC 60664-1 / IEC 60664-3



## Technical data

### Device overview, residual current transformer, type A / 0.03 A secondary current

Type	Transformation ratio	Max. primary residual current in A	Max. wire diameter in mm	Round conductor in mm	Overall width in mm	Weight (kg)	Item no.
DACT 20	600/1	18 <sup>1)2)</sup>	4 x approx. 8 (rm-10 qmm) or 8 x 5,5 (rm-6 qmm)	20	82	0.15	15.03.201

### Accessories

Snap-on mounting	15.02.144
------------------	-----------

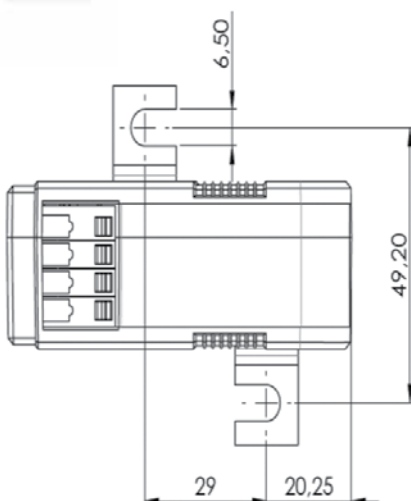
<sup>1)</sup> When using the analog inputs of the UMG 96RM-E, UMG 96RM-PN, UMG 509-PRO and UMG 512-PRO

<sup>2)</sup> If the residual current transformers of series DACT are used in connection with the UMG 20CM, the metering range of the UMG 20CM can be raised from 900 mA or 1 A to 14 A or 15 A through interposition of the loads, item no. 15.03.085.



## Dimension drawing

All specifications in mm



Basic Information for the use of current transformer can be found in chapter 10.

# Differential current transformers type B+

**Main features**

- Recording of type B+ residual currents (up to 300 mA)
- Prealarm in case of malfunction
- Standard interface 4–20 mA
- Continuous monitoring of residual currents
- Power supply voltage 24 V DC
- Compact, solid plastic housing
- Alternative to insulation measurement for testing of stationary electrical installations and equipments.
- Provisions for fire and facility protection can easily be implemented
- Decentralised, direct disconnection of equipment parts
- Suitable for the UMG 96RM-E



## Technical data

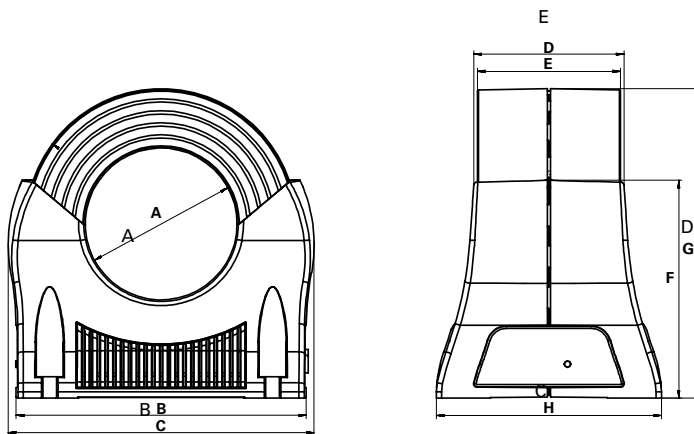
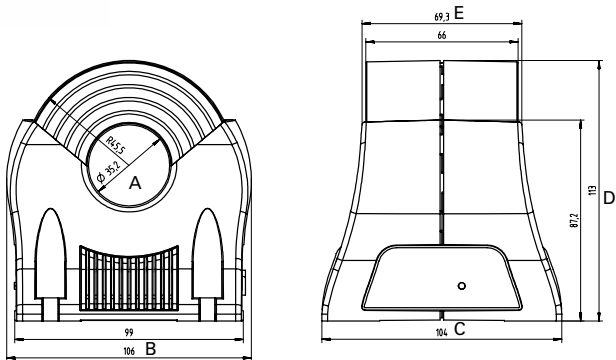
Overview of product variants						
Type	Operating voltage DC	Max. primary residual current in mA	Max. wire diameter in mm	Busbar in mm	Weight (kg)	Item number
CT-AC/DC Typ B+ 35 RCM	24 V (21.6 ... 26.4 V)	300	4 x approx. 14 (rm=35 qmm) or 8 x 10 (rm=10 qmm)	max. 30 x 10	0,86	15.03.469
CT-AC/DC Typ B+ 70 RCM	24 V (21.6 ... 26.4 V)	300	4 x approx. 28 (rm=240 qmm) or 8 x 23 (rm=150 qmm)	max. 60 x 20	1,20	15.03.468
Accessories						
<b>Power supply with step shape</b> prim. 85 – 264 V 50/60 Hz, sec. 24 V DC; 4,2 A Dimensions in mm (W x H x D): 70 x 90 x 54.5; weight: ca. 270 g						16.05.014

Dimensions residual current transformer type B+								
Type	Dimensions in mm							
	A	B	C	D	E	F	G	H
CT-AC/DC Typ B+ 35 RCM	35	99	106	69	66	87	113	104
CT-AC/DC Typ B+ 70 RCM	70	134	141	69	66	100	143	104



## Dimension diagrams

All dimensions in mm



# Current transformer type CT-20, class 1

**Precise and efficient**

- Can be used with operational currents up to max. 63 A and for residual currents from 1 mA to 1,000 mA acc. type A
- Compact construction
- Ratio 700/1
- Primary window can be used for insulated cable Ø 7.5 mm (max.)
- For use on a 3-phase circuit breaker with a phase spacing of 17.5 mm
- DIN rail mounting (35 mm) via rail clamps (optional)
- Special version for the monitoring device UMG 20CM



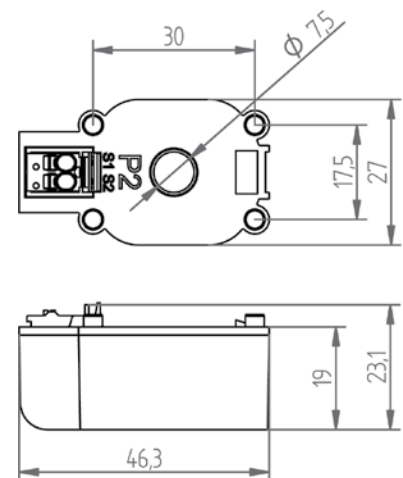
## Technical data

Current transformer CT-20	
<b>Environmental conditions</b>	
Position of installation	Indoor usage; only for insulated conductors
Ambient temperature	-10 ... +55 °C
Relative humidity	5 ... 85 % (no condensation)
Protection class	IP20
<b>Application conditions</b>	
Measuring accuracy	1 %
Thermal short time rated current	60 x I <sub>n</sub> / 1 s
Thermal continuous current	100 %
Rated isolation level	0.72 / 3 / kV
Rated frequency	50 / 60 Hz
Insulation class	E (120 °C)
Cable feed through window	Ø 7.5 mm
Secondary conductor	Wire cross section: 0.2 ... 1.5 mm <sup>2</sup> Rigid, flexible, spring type terminal



## Dimension diagrams

All dimensions in mm



Current transformer CT-20 – operating or differential current transformer type A								
Operating or residual current CT type A	Max. operating current in A	Residual current in mA	Transformation ratio	Max. diameter, primary conductor in mm	Class	Dimensions in mm (W x H x D)	Weight (kg)	Item no.
CT-20	63 (with burden)	10 ... 1000	700/1	7.5	1	27 x 46 x 23	0.05	<b>15.03.082</b>
<b>Accessories</b>								
Mounting clip	For DIN rail EN 50022-35, suitable for type CT-20					41 x 14 x 27	0.001	<b>09.09.010</b>
Ready-made connection cable	1.5 m with burden (0,8 Ω) and spring type terminal adapter for operating current measurement							<b>15.03.085</b>

## Split-core current transformer type SC-CT-21, class 1

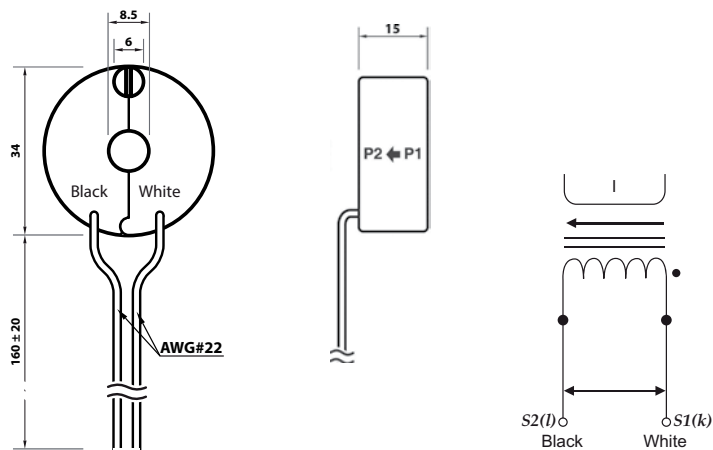
### Micro-fine and high-precision

- Compact, divisible, split-core current transformer
- Suitable for residual current measurement (10 ... 1000 mA)
- High measurement accuracy
- Simple installation thanks to clip technology
- UL and EN 61010-1 certified
- Specially designed for use with the UMG 20CM



### Dimension diagrams

All dimensions in mm



### Technical data

Technical data	
Measuring accuracy	1 %
Current measurement range	0.01 ... 1 A
Max. continuous current	35 A
DC resistance	33 Ohm ± 10 %
Insulation category	CAT III
Environmental conditions	
Position of installation	Indoor usage
Ambient temperature	-20 ... +50 °C
Storage temperature	-30 ... +90 °C
Relative humidity	< 85 % (no condensation)
Protection class	IP20

Split-core current transformer SC-CT-21								
Type	Residual current (mA)	Transformation ratio	Max. primary conductor diameter in mm	Class	Accuracy (%)	Dimensions in mm (W x H x D)	Weight (kg)	Item no.
SC-CT-21	10 ... 1,000	700/1	8	1	1	35 x 35 x 16	0.05	15.03.084

Basic Information for the use of current transformer can be found in chapter 10.

# 6-fold DIN rail current transformer CT-6-20

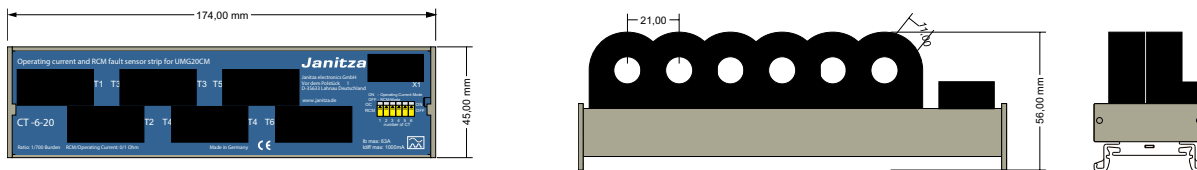
## Monitor, detect and treat

- For operational current – as well as RCM-monitoring suitable
- Residual current acquisition with integrated current transformers (residual currents per IEC 60755 type A)
- 6 measurement channels
- Compact construction
- Parallel acquisition and processing of measured values
- Use in distribution outputs for consumers and systems
- Special version for the monitoring device UMG 20CM



## Dimension diagrams

All dimensions in mm



## Technical data

General data	
Number of measuring channels	6 (current transformers integrated)
Monitoring	Parallel, real effective value measurement ("True RMS")
Evaluation	Residual – or operating – currents (configurable as required in the individual application)
Rated isolation level	4 kV
Transformer rated voltage	max. 720 V AC
Transformer rated frequency	50 ... 60 Hz
Therm. rated short-term current	60 x I <sub>n</sub> / 1 sec.
Therm. Continuous current	100%
Ambient temperature	-10 ... +55 °C
Class	1
Protection class	E
Protection class	IP20

6-fold DIN rail current transformer CT-6-20 (operating and residual current transformer type A)										
Type	Operating mode*1	Operating current with load in A	Residual current in mA	Number of measuring channels*2	Transformation ratio	Measurement accuracy	Max. primary conductor diameter in mm	Dimensions in mm (W x H x D)	Weight (kg)	Item no.
CT-6-20	Residual or operating currents	0 ... 63	10 ... 1,000	6	700/1	1	11	174 x 45 x 56	0.30	14.01.630

Accessories	
Ready-made connection cable 1.5 m twisted, shielded with connector	08.02.440

\*1 Pre-configurable as needed via DIP switch

\*2 Measurement transformer integrated.

# ACCESSORIES



# Voltage tap

## ZK4S, ZK4B and ZK4R – Compact and secure

- Terminals to tap off the voltage on current-conducting bus bars
- Suitable for tapping off voltage for energy measurement devices
- Fusing directly on the rail
- Primary connection with M8 Allen screw
- Short-circuit resistance 70 kA to 400 V / 50 Hz
- High operational reliability



Fig.: ZK4S and ZK4B



## Dimension diagrams

All dimensions in mm

### ZK4S-ZK4B

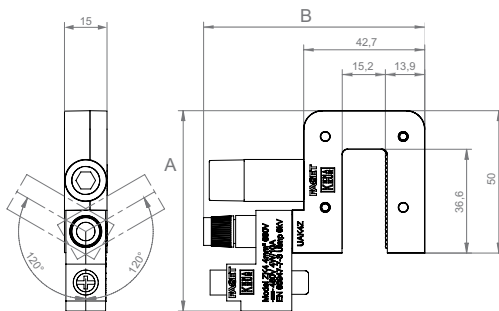


Fig.: Insulated tool ZK4R



## Technical data

Voltage tap	
Max. operating voltage	690 V
Test voltage / pulse	3 kV / 50 Hz 6 kV
In max.	10 A
Insulation class	E (max. 120°)
Fuse type	5 x 25 mm (with notification), 10 A SIBA DIN 41576-2
Ambient temperature	-5 ... +40 °C*1
Temperature increase, bus bar	Max. 75 K*1
Primary connection	M8 Allen screw
Allen size	Number 6
Max. bus bar thickness	4 – 15 mm
Housing	Polyamide (PA6.6)
Terminal material	Nickel plated brass

\*1 Max. temperature of the primary rail 120 °C (total of ambient temperature and temperature increase of the rail)

Device overview – Voltage tap								
Type	Color	Description	Fuse (A)	Cross-section connection line (mm <sup>2</sup> )	Dimensions in mm		Weight (kg)	Item no.
					A	B		
ZK4S	Black	With fuse	6.3	1.5 – 4	71	78	0.2	10.11.525
ZK4B	Blue	Without fuse	-	0 – 16	58.2	76	0.1	10.11.526
Accessories								
1 x voltage tap set	3 x ZK4S (item no. 10.11.525); 1 x ZK4B (item no. 10.11.526)						0.7	10.11.527
ZK4R	Insulated tool for fixing the tap; 1,000 V, EN / IEC 60900						0.9	10.11.528



# Voltage tap

## ZK4/M6 and ZK4/M8 – fused measurement voltage connection

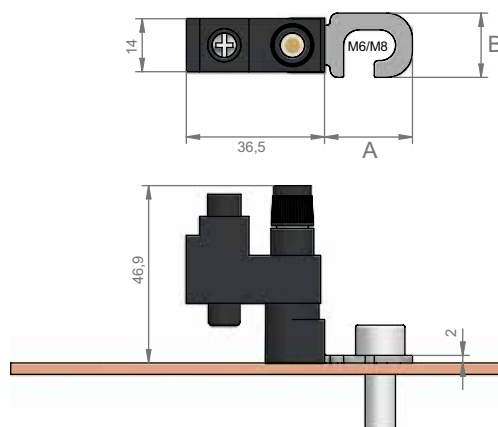
- Fused voltage tap for measurement purposes
- Simple installation underneath existing fastening points, directly on the current bus bar
- Compact housing
- Delivered with a 5 x 25 mm, 2 A, 450 V, F, 70 kA fuse



## Dimension diagrams

All dimensions in mm

### ZK4M6-M8



## Technical data

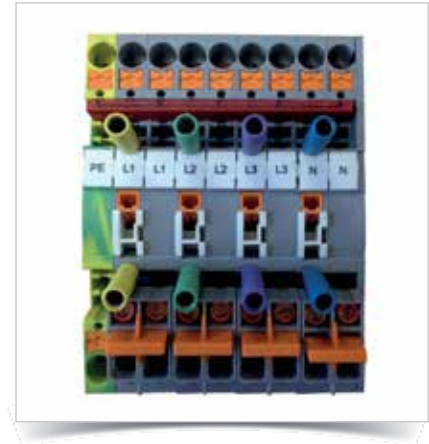
Environmental conditions	
Installation location	Indoor usage (suitable for copper rails)
Ambient temperature range	-10 ... +55 °C
Relative humidity	5 to 85 % (no thawing)
Protection class	IP20 (basic insulation)
Application conditions	
Standard	IEC 60947-7-3
Maximum operating voltage	400 V ~
Test voltage	3 kV / 50 Hz
Surge voltage	6 kV 1.2 / 50 µs
I <sub>max</sub>	2 A
Voltage drop	< 500 mV ~
Fuse	2 A, 450 V, F, 70 kA, 5 x 25 mm, ceramic (SIBA Part.no. 7008913.2)
Torque	Max. 2.0 Nm

Device overview – Voltage tap								
Type	Color	Primary connection (mm)	Fuse (A)	Cross-section connection line (mm <sup>2</sup> )	Dimensions in mm		Weight (kg)	Item no.
					A	B		
ZK4/M6	Black	6	2	1.5 – 4	18.8	13.5	0.03	10.11.534
ZK4/M8	Black	8	2	1.5 – 4	23.2	17	0.03	10.11.535

# Current transformer terminal block

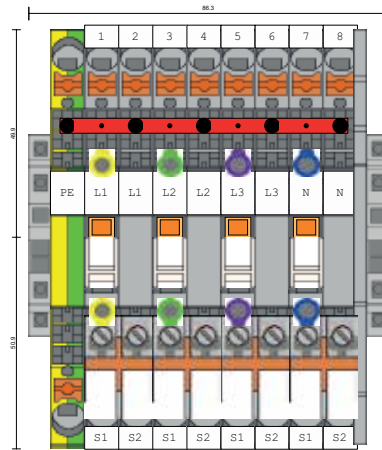
## Modular and reliable

- Application: Short circuiting of current transformers, parallel measurement for cross checking ("quasi calibrating") measurement devices
- For installation on DIN rails
- Completely equipped for 4 conductors
- Insulated bridges for grounding and short circuiting of the CT terminal



## Dimension diagrams

All dimensions in mm



## Technical data

General data	
DIN mounting rail installation	35 mm DIN rail
Connection max.	4 CTs
4 pairs, 2-conductor, disconnecting and measurement terminals with contact protected test sockets	
Test connector (ø)	4 mm (with switching bridge)
Rated voltage EN	500 V
Measurement surge voltage	6 kV
Rated current	30 A
Degree of pollution	3
Connection design	CAGE CLAMP® S
Type of conductor	Single or fine-stranded
Fine stranded diameter	0.5 – 6 mm <sup>2</sup>
"f" + "e" diameter	0.5 ... 10 mm <sup>2</sup>
"f" diameter with AEH	0.5 ... 6 mm <sup>2</sup>
Stripping length	13 – 15 mm

Each terminal is labelled. The terminal position S2 on each transformer is connected to ground potential via a fixed, pre-installed bridge. Each pair of disconnecting and measurement terminals is equipped with a yellow switch lock for the disconnect lever. 2 disconnect levers are coupled together via an interlocking cap.

Current transformer terminal block								
Type	Rated current (A)	Rated voltage EN (V)	Rated voltage surge (kV)	Type of conductor	Cross-section (mm <sup>2</sup> )	Dimensions in mm (W x H x D)	Weight (kg)	Item no.
Current transformer terminal block	30	500	6	Single or fine-stranded	0.5 – 6	85 x 190 x 65	0.3	15.07.001

# Humidity and temperature sensor JFTF-I

## High-precision and reliable measurement

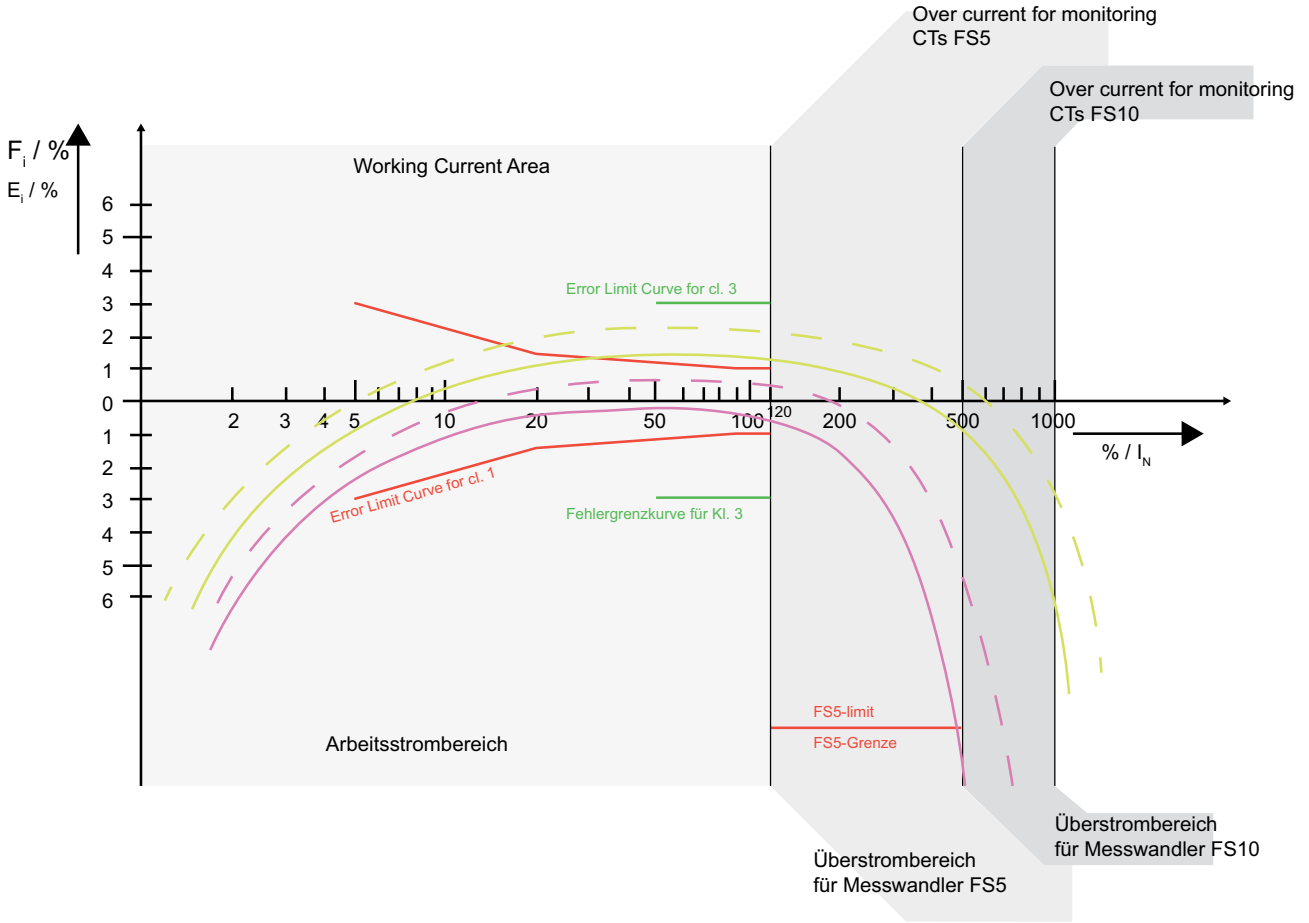
- For the measurement of relative humidity and temperature of the ambient air
- Intended for the measurement of unpolluted, non-condensing air without any positive or negative pressure
- High measurement accuracy
- A sintered filter protects the sensor from external contaminants
- The sensors themselves are fitted in a metal tube so that the warming up of the analogue unit has no detrimental influence on the measurement.
- FBM modul DI8-AI8 required (Item no. 15.06.079)



## Overview of devices

Humidity and temperature sensor		
Designation	Type	Item no.
<ul style="list-style-type: none"> <li>• With current output (2-wire system) 4 ... 20 mA</li> <li>• Operating voltage 15 ... 36 V DC, depending on total apparent load</li> <li>• Relative humidity output 4 ... 20 mA corresponding to 0... 100 %, Load resistance 200 ... 500 Ω</li> <li>• Temperature output 4 ... 20 mA corresponding to -20... +80 °C Load resistance 200 ... 500 Ω</li> <li>• Current consumption max. 40 mA</li> </ul>	JFTF-I	<b>15.06.074</b>

Current transformer error curve



- Example for a measuring c.t. of cl. 1 FS5 and 1/1 burden  
Beispiel eines Strom-Messwandlers der Kl. 1 FS5 bei 1/1 Bürde
- Example for a measuring c.t. of cl. 1 FS5 and 1/4 burden  
Beispiel eines Strom-Messwandlers der Kl. 1 FS5 bei 1/4 Bürde

- Example for a protection c.t. 10P10 and 1/1 burden  
Beispiel eines Schutzwandlers 10P10 bei 1/1 Bürde
- Example for a protection c.t. 10P10 and 1/4 burden  
Beispiel eines Schutzwandlers 10P10 bei 1/4 Bürde



# 07 Accessories

Accessories – Integration and installation aids

Page 287

- Adapters for DIN rail installation
- Seals
- Blank plastic covers
- Adapter plates
- Ethernet front panel connector and protective covers



## ACCESSORIES – INTEGRATION AND INSTALLATION AIDS



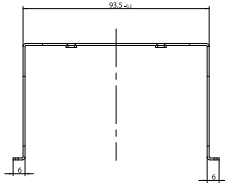
## Adapters for DIN rail installation

Description	Type	Item no.
Adapter for DIN rail mounting Dimensions in mm (W x H x D): 85 x 60 x 90 UMG 96-S2 / UMG 96RM / UMG 96RM-M	AH96	52.22.666

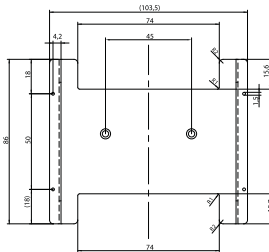


### Dimension diagrams

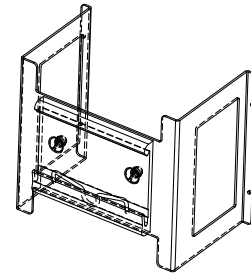
All dimensions in mm



Front view



View from below



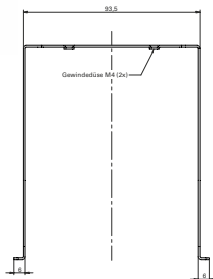
3D view

Description	Type	Item no.
96 mm adapter for DIN rail mounting UMG with Profibus Dimensions in mm (W x H x D): 85 x 113 x 90 UMG 96RM-E / UMG 96RM-EL / UMG 96RM-CBM / UMG 96RM-P / UMG 96RM-PN / UMG 96-PA / UMG 96-PQ-L	AH96P	52.22.667

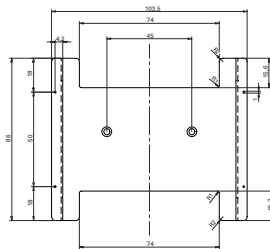


### Dimension diagrams

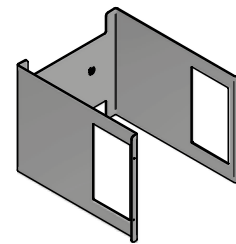
All dimensions in mm



Front view



View from below



3D view

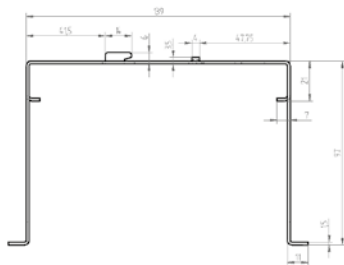


Description	Type	Item no.
Adapter for DIN rail mounting Dimensions in mm (W x H x D): 74 x 161 x 97	AH144	
UMG 509-PRO / UMG 512-PRO		29.04.154

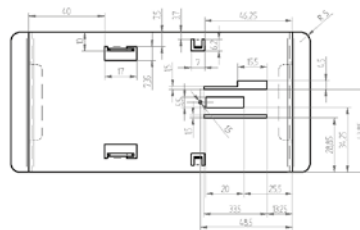


## Dimension diagrams

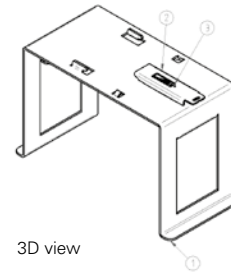
All dimensions in mm



Front view



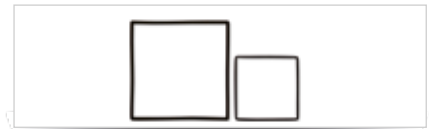
View from below



3D view

## Further accessories

Overview		
Description	Type	Item no.
Sealing (to IP54) for UMG 96-S2, UMG 96RM, UMG 96RM-P, UMG 96RM-CBM, UMG 96RM-M, UMG 96RM-E, UMG 96RM-EL, UMG 96RM-PN, UMG 96-PA, UMG 96-PQ-L	D96	29.01.065
Sealing (to IP42) for UMG 509-PRO, UMG 512-PRO and Prophi®	D144	29.01.903
Blank cover in black plastic, 96 x 96 mm	BA96	29.12.001
Blank cover in black plastic, 144 x 144 mm	BA144	29.12.002
Adapter plate 144 mm to 96 mm, color RAL 7032	AB144/1	29.12.912
Adapter plate 144 mm to 96 mm, color RAL 7035	AB144/2	29.12.913
Ethernet front panel feed-through with extension frame and RJ45 socket type VS-08-BU-RJ45/BU	EFD	13.08.016
Protective cover, flat design for covering the contact insert RJ45	EFDD	13.08.017
Spacer to reduce the installation depth by 8,4 mm for the UMG 96-PA. External dimensions: 108 x 108 x 8,6 mm (WxHxD) Suitable for sheet metal up to 6 mm.	GEH96	29.01.127



# 08 Power factor correction (PFC) and harmonics filter

<b>Prophi® power factor controller</b>	Page 293
<ul style="list-style-type: none"><li>• Optimised control for longer service life</li></ul>	
<b>PFC power capacitors</b>	Page 301
<ul style="list-style-type: none"><li>• 3-phase power capacitors in aluminium cans</li></ul>	
<b>Automatic power factor correction systems without reactors</b>	Page 307
<ul style="list-style-type: none"><li>• Automatic power factor correction, modular design (up to 500 kvar)</li><li>• Automatic power factor correction, extractable module, up to 100 kvar</li></ul>	
<b>Automatic de-tuned power factor correction systems</b>	Page 313
<ul style="list-style-type: none"><li>• Automatic de-tuned power factor correction (harmonics filter), compact design</li><li>• 7% de-tuned power factor correction (harmonics filter)</li><li>• 14% de-tuned power factor correction (harmonics filter)</li><li>• De-tuned capacitor modules</li></ul>	
<b>Dynamic power factor correction systems (real time PFC)</b>	Page 321
<ul style="list-style-type: none"><li>• 7% de-tuned dynamic power factor correction</li><li>• 14% de-tuned dynamic power factor correction</li><li>• De-tuned dynamic PFC module</li></ul>	
<b>Power factor correction spare parts and accessories</b>	Page 329
<ul style="list-style-type: none"><li>• Component selection table for a nominal voltage 400 V – 50 Hz</li><li>• Accessory – Passive harmonics filter</li><li>• Electronic circuit breaker (thyristor controller)</li></ul>	



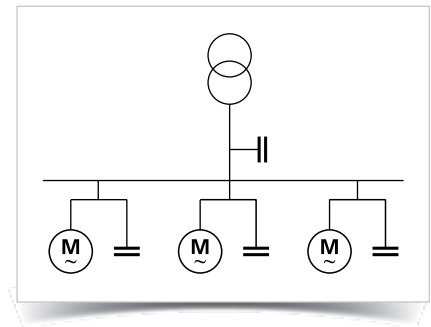
# POWER FACTOR CORRECTION (PFC) AND HARMONICS FILTER



## Types of power factor correction (PFC)

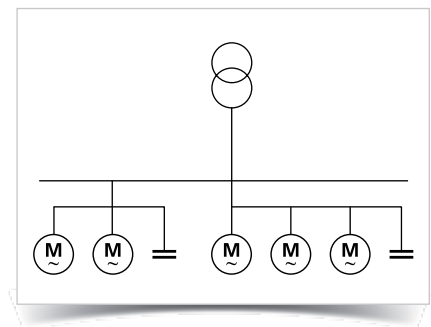
### Individual PFC

- A suitably sized capacitor will be connected in parallel to each inductive load
- Relieving of the load on the supply line as well as the switching equipment
- No separate switching equipment required for the capacitor and no controller required
- Economic with longer duty cycles and greater power draw



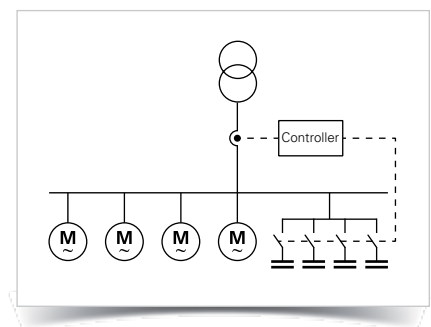
### Group PFC

- Will be implemented with load groups with the same operational behaviour
- For multiple inductive loads, that are always operated together
- The supply lines and group switches will be relieved of reactive current and the simultaneity factor results in a smaller capacitor size



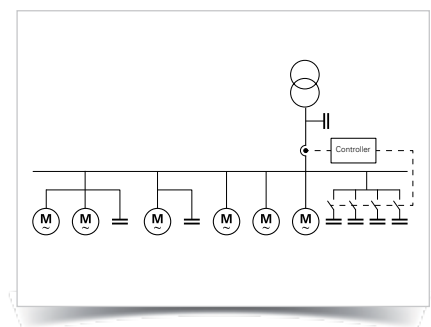
### Automatic central PFC (APFC)

- The central PFC will be integrated into the main LV distribution
- Near constant, good power factor that adapts automatically through a power factor controller via contactors or thyristor switches
- The output of the capacitors installed will be better utilised
- Better adaptation of the capacitor power to the reactive power demand
- Networks with harmonics can be more easily detuned through APFC



### Mixed PFC

- Combination of individual, group and central PFC



# Prophi® POWER FACTOR CONTROLLER

Hybrid switching



Harmonics display



Dynamic PFC



Smart control



## Interfaces / communication

- RS485

## Communication / protocols

- Modbus RTU
- Modbus KTR
- ASCII Out
- Extern
- Slave Hybrid
- Slave Mode
- Master Mode

## Triple Safety

- Temperature monitoring
- Monitoring the capacitor protective switching cycles
- Monitoring of over-current
- Single-phase reactive current compensation monitoring

## Measuring voltage

- 3-phase  
50–760 V (L-L), 30–440 V (L-N)  
30–525 V (L-N)

## Power quality

- Harmonics up to the 33rd
- THD-U in%
- THD-I in%

## Intelligent control

- Minimised number of switching cycles
- Compensated number of contactor switch cycles
- Optimised service life
- Mixed control (single and three-phase)
- Separate control of single-phase capacitors
- Sequential switching
- Cyclic switching

## Switching outputs

- 15 relay outputs, freely programmable
- 12 transistor and 12 relay outputs for hybrid PFC

## Alarm messages

- Undervoltage detection
- Overvoltage detection
- Under-compensation
- Measurement current exceedance
- Harmonics threshold values
- Delivery of active power
- Overtemperature
- Dropping below the measurement current
- C-defect
- Modbus error
- Switching cycle warning

## Display mode

- Display three measured values simultaneously
- Graphical representation of harmonics in bar graph form
- Three-digit display of power factor (cos phi), switchable (tan phi)
- Display of controlled steps, fault messages and time
- Display of apparent current, active current and reactive current in display mode

## Areas of application



- Automatically regulated power factor correction
- Choked power factor correction
- Harmonics filter
- Voltage stabilisation by means of dynamic PFC
- Mixed operation (hybrid switching) contactors and thyristor switching

## Main features

- 12 or 13 switching outputs
- Extended measured voltage range (up to 760 V ~ L-L)
- Control of inductive compensation systems possible
- 20 pre-programmed control series
- Control series editor
- Graphical display 128 x 64 pixels
- Plain language menu navigation
- Four-quadrant operation
- Automatic initialisation
- Display of various grid parameters
- Display of harmonics
- Display of distortion factor THD-V / THD-I
- Monitoring of the capacitor current
- Saving of the maximum values
- Saving of the switching cycles and times
- Manual / Automatic mode
- Zero voltage shutdown
- Various error messages / alarm relay
- Error memory
- Test run of the system with error analysis
- Control of inductive compensation systems possible
- Voltage, current, frequency, active power, reactive power, apparent power
- Harmonics of the voltage (up to the 33rd / up to the 16th (even))
- Harmonics of the current (up to the 33rd / up to the 16th (even))

### Alarm output programmable for ...

- Undervoltage detection / Overvoltage detection
- Under-compensation / Over-compensation
- Under-current / Over-current
- Harmonics threshold values
- Delivery of active power
- Overtemperature
- Message for delivery of active power
- Measured voltage error
- Switching cycle warning
- Modbus error
- C-defect



Fig.: Auto-Mode



Fig.: Display-Mode

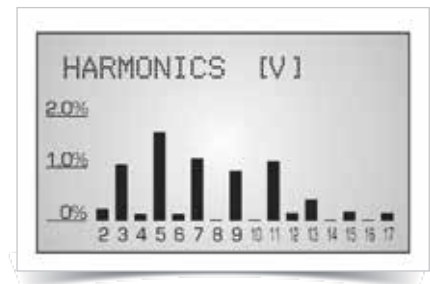


Fig.: Bargraph-Mode

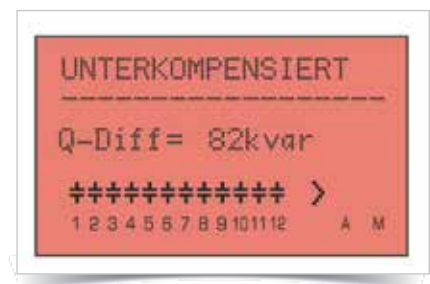


Fig.: Error message (customisable backlight)

### Functional principle

- Single-phase/three-phase electronic measurement system
- Detection of the reactive and active current portion of the grid via the current and voltage circuit
- Switching in or out of the capacitor stages via the outputs in the event of deviations in the set power factor
- Switching of capacitors via contactors or semiconductors
- Regulation via capacitor air contactors is implemented in an optimised manner
- Transistor outputs for the near-realtime control of semiconductor switches

### Fan control

- Development of fan control via integrated temperature sensors and a fan
- Uses the signal relay
- Programming of a lower or upper limit temperature necessary

### LCD display

- Graphical display 128 x 64 pixels
- Display a comprehensive selection of measurement parameters

### Overtemperature shut-down

- The overtemperature shut-down switches off the capacitor stages connected
- This results in the reduction of the interior temperature of the switching cabinet and protects the capacitors
- Programming of a lower or upper limit temperature as well as the pause time

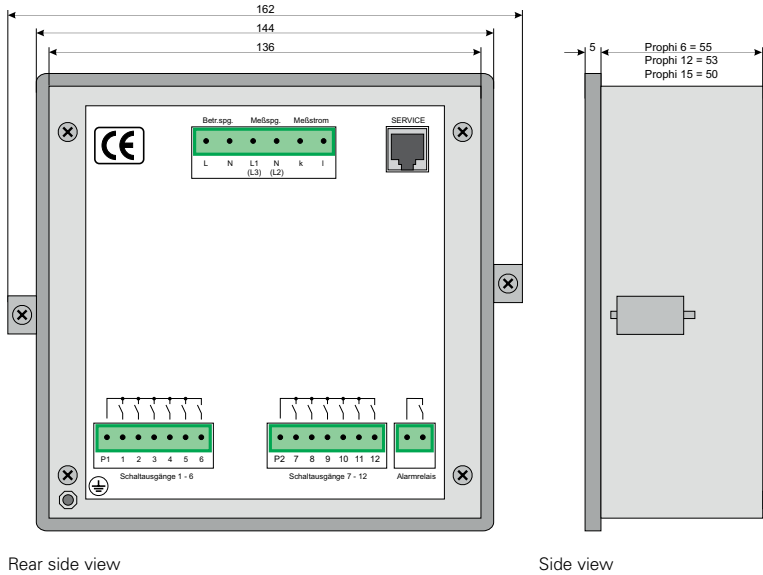
### Interface

- Two independent potential-free RS485 interfaces
- The Modbus RTU, Modbus KTR, ASCII out, Slave Hybrid, Slave Mode, and Master Mode protocols are available via the RS485s
- Integration of PLC systems, building management systems or energy management systems
- Modbus transfer rates: 9.6 – 256 kBit/s



## Dimension diagrams

All dimensions in mm



Rear side view

Side view

**Cut out: 138<sup>+0,8</sup> x 138<sup>+0,8</sup> mm**



## Typical connection

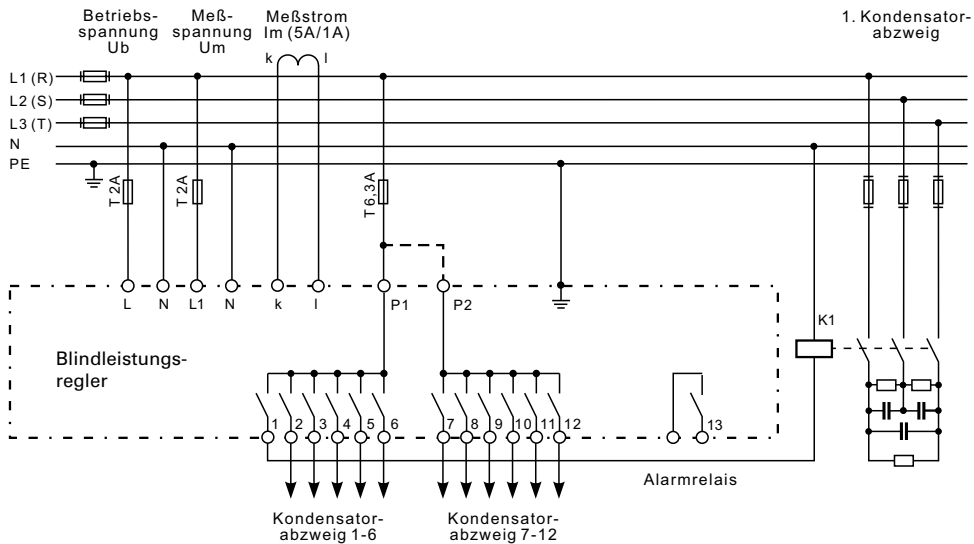


Fig.: Connection example for the Prophi® power factor controller





## Device overview and technical data

Relay outputs (conventional)	Transistor outputs (dynamic)	Alarm output	Target cos-phi change over 1/2	Measurement voltage 30 – 440 V (L-N) 50 – 760 V (L-L)	Operating voltage 110 – 440 V ±15 %	Measurement voltage 30 – 525 V (L-N) Operating voltage 110 – 230 V	RS485 interface	Software GridVis® Essentials	Dimensions in mm (W x H x D)	Weight in kg	Type	Item number
6	-	•	-	-	•	-	-	-	144 x 144 x 55	1	Prophi® 6R	14.16.038
12	-	•	-	•	-	-	-	-	144 x 144 x 53	1	Prophi® 12R	14.16.028
-	6	•	-	-	•	-	-	-	144 x 144 x 55	1	Prophi® 6T	14.16.039
-	12	•	-	•	-	-	-	-	144 x 144 x 53	1	Prophi® 12T	14.16.033
12	12	•	-	•	-	-	-	-	144 x 144 x 53	1	Prophi® 12TR	14.16.040
12	-	•	•	•	-	•	-	-	144 x 144 x 53	1	Prophi® 12RS	14.16.029
12	12	•	•	•	-	•	-	-	144 x 144 x 53	1	Prophi® 12TRS	14.16.036
-	12	•	•	•	-	•	-	-	144 x 144 x 53	1	Prophi® 12TS	14.16.041
15	-	•	•	•	-	•	-	-	144 x 144 x 50	1	Prophi® 15R III	14.16.037
-	15	•	•	•	-	•	-	-	144 x 144 x 50	1	Prophi® 15T III	14.16.042

• = included - = not possible

General	Prophi®
Use in low and medium voltage networks L-N or L-L	•
Accuracy voltage measurement	1%
Accuracy current measurement	1%
Accuracy cosphi measurement	1%
Accuracy power measurement	2%
Accuracy frequency measurement	1%
Accuracy harmonics measurement	2%
<b>RMS – momentary value</b>	
Current, voltage, frequency	•
Effective, reactive and apparent power	•
Power factor	•
<b>Recording of the mean values</b>	
Power factor	•
<b>Power quality measurement</b>	
Harmonics per order / current and voltage, 1-phase	Prophi 6: 3.–19., odd Prophi 12: 3.–33., odd Prophi 15: 3.–33., odd
Distortion factor THD-U in%, 1-phase	•
Distortion factor THD-I in%, 1-phase	•
<b>Measured data recording</b>	
Maximum values	•
<b>Displays and inputs / outputs</b>	
Digital display, 4 / 6 buttons	•
Relay outputs (as switch output)	6 / 12 / 15 See overview of devices
Transistor outputs (as switch output)	6 / 12 / 15 See overview of devices
Alarm output (as switch output)	1
Digital input (for tariff changeover)	1 See overview of devices
Temperature sensor (internal)	1

<b>Communication</b>	
<b>Interface</b>	
RS485: 9,6–256 kbps	See overview of devices
<b>Protocols</b>	
Modbus RTU	•
<b>Error messages</b>	
Under-voltage / over-voltage	•
Under compensated / over compensated	•
Measuring current underrun	•
Overtemperature	•
Harmonics (harmonic distortion)	•
Overcurrent	•
Switching cycle warning	•
Service interval	•
<b>Technical data</b>	
Supply voltage L-L, L-N AC	See overview of devices
Measurement in which quadrants	4
Networks	TN, TT, (IT)
Measurement in multi-phase networks	3 ph
Power consumption	max. 5 VA
<b>Measured voltage input</b>	
Overvoltage category	CAT III
Measured range, voltage L-N, AC (without potential transformer)	See overview of devices
Measured range, voltage L-L, AC (without potential transformer)	See overview of devices
Voltage tolerance range	+10% , -15%
Back-up fuse	2 A ... 10 AT
Measurement surge voltage	4 kV
Test voltage relative to ground	2.200 V AC
Frequency measuring range	42 ... 80 Hz
Sampling rate	10 kHz (at 50 Hz)
<b>Measured current input</b>	
Signal frequency (Basic frequency)	45 ... 80 Hz
Nominal current at .../5 A (.../1 A)	5 A (1 A)
Operating current	50 mA (10 mA)
Upper measurement current	6 A
Power consumption	approx. 0.2 VA
Updating the display	1 time per second
Zero voltage triggering	< 15 ms
<b>Inputs and outputs</b>	
Number of digital inputs (for tariff changeover)	1, see overview of devices
Relay outputs (as switch output)	6 / 12 / 15, see overview of devices
Back-up fuse	10 AT
Switching voltage (relay)	max. 250 V AC
Switching power	max. 1.000 W

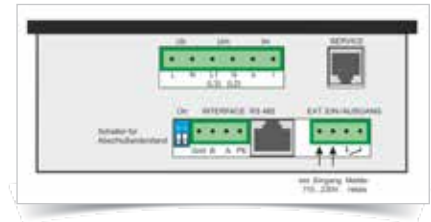


Fig.: Prophi® interface

Mechanical service life	> 10 <sup>7</sup> switching cycles
Electrical service life	> 10 <sup>5</sup> switching cycles
<b>Transistor outputs (as switch output)</b>	<b>6 / 12, see overview of devices</b>
Switching voltage (transistor)	5 ... 30 V DC
Switching current (transistor)	max. 50 mA
Alarm output (as switch output)	1
Target cosphi changeover (current consumption)	Input 230 V AC
<b>Mechanical properties</b>	
Weight	1000 g
Device dimensions in mm (W x H x D)	see overview of device
Protection class per IEC 60529	Front: IP54, Rear: IP20
Installation	Front panel installation
Connecting phase (U / I), Single core, multi-core, fine-stranded Terminal pins, core end sheath	0.08 to 2.5 mm <sup>2</sup> 1.5 mm <sup>2</sup>
<b>Features</b>	
Display of capacitor currents	•
Display of switch-on times for the individual stages	•
Display of switching cycles per stage (only relay)	•
Zero voltage triggering	•
Automatic configuration	•
Password protection	•
<b>Environmental conditions</b>	
Temperature range	Operation: -10 ... +55 °C *1 Storage: -20 ... +60 °C
Relative humidity	15 to 95%
Operating altitude	0 ... 2,000 m above sea level
Degree of pollution	2
Mounting position	any
<b>Electromagnetic compatibility</b>	
Electromagnetic compatibility of equipment	Directive 2004/108/EC
Electrical appliances for application within particular voltage limits	Directive 2006/95/EC
<b>Equipment safety</b>	
Safety requirements for electrical equipment for measurement, regulation, control and laboratory use – Part 1: General requirements	IEC/EN 61010-1
Part 2 – 008: Particular requirements for testing and measuring circuits	IEC/EN 61010-1-08
Protection class	I = Device with protective conductor
<b>Noise immunity</b>	
Industrial environment	DIN EN 61326-1, Table 2; (IEC 61326-1)
<b>Emissions</b>	
Class B: Residential environment	DIN EN 61326-1; (IEC 61326-1)
Class A: Industrial environment	DIN EN 61326-1; (IEC 61326-1)
<b>Safety</b>	
Europe	CE labelling

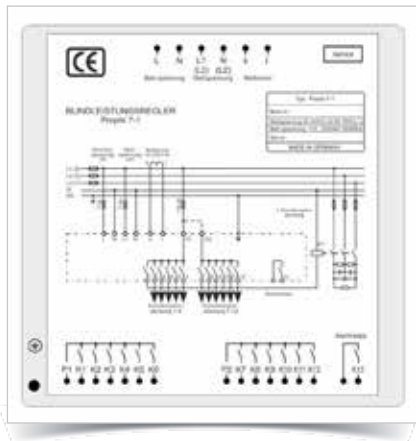


Fig.: Prophi® rear view

Comment: For detailed technical information please refer to the operation manual and the Modbus address list.

\*1 Devices with the "RS485 interface" option are only suitable for an operating temperature range of -10 to +50 °C.



# PFC POWER CAPACITORS



**High tolerance of inrush currents**

- Optimised metal spraying process
- Wave-cut film

**Long service life**

- Highend impregnation technology
- Good thermal dissipation
- High quality base materials

**Reliable connection technology**

- Connection adapter for reliable long term connections

**Fivefold safety**

- Self-healing technology
- Dry technology
- Over-pressure disconnecter
- Segmented capacitor film
- Integrated discharge device

## Areas of application



- Motor fixed PFC
- Group PFC
- Automatic power factor correction
- Detuned power factor correction systems
- Harmonics filter
- Dynamic power factor correction systems

## Main features

### Fivefold safety

- Self-healing technology
- Dry technology
- Over-pressure disconnecter
- Segmented capacitor film
- Integrated discharge device

### Long service life (up to 170,000 hours) and high operational reliability

- Highend impregnation technology
- Excellent thermal dissipation
- High quality base materials

### Reliable connection technology

- Connection adapter for reliable long term connections

### High inrush currents withstand capability

- Optimised metal spraying process
- Wave-cut film design

### High of overload withstand capability

- Max. over-current:  $2.2 I_n$
- Max. inrush current:  $300 \times I_n$

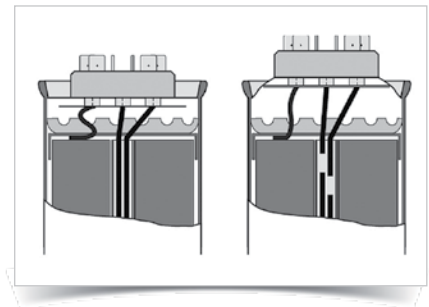


Fig.: Principle of over-pressure disconnecter



Fig.: Self-healing, segmented capacitor film



Fig.: The connection adapter offers a low transfer resistance and a permanent, fixed electrical and mechanical contact

**Low loss**

- 0.2 Watt/kvar dielectric loss
- 0.5 Watt/kvar total power dissipation

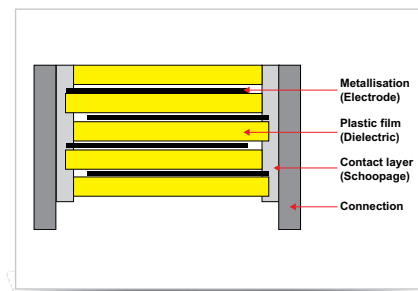


Fig.: Contacting (metal spraying) of the metallised Polypropylene film (Dielectric)



## Technical data

Technical data and limit values for power capacitors		
Standards		IEC 60831-1+2, EN 60831-1+2
Output range	QR (kvar)	0.3 – 40
Nominal voltage range	UR (V)	400 V*1
Over-voltage	$U_{max}$	$U_n + 10\%$ (up to 8 h daily) / $U_n + 15\%$ (up to 30 mins daily) $U_n + 20\%$ (up to 5 mins daily) / $U_n + 30\%$ (up to 1 min daily)
Overcurrent	$I_{max}$	$2.2 \times I_n$ (at nominal voltage, 50 Hz)
Inrush current withstand capability	IS	Up to $300 \times I_n$
Dielectric losses	Pdiel.	< 0.2 Watt per kvar
Total capacitor losses	Pv	< 0.5 Watt per kvar
Nominal frequency	f	50 / 60 Hz
Capacitor tolerance		-5 ... + 10%
Test voltage (terminal / terminal)	VTT	$2.15 \times U_n$ , AC, 2 s / $1.85 \times U_n$ , AC, 18 s
Test voltage (terminal / housing)	VTC	3,900 V, 2 s
Service life expectancy	t LD(Co)	Up to 170,000 h
Ambient temperature		Class: -25/D Max. temperature +65 °C Max. 24 h average = +45 °C Max. 1 year average = +35 °C Lowest temperature = -40 °C
Max. housing temperature	Tg	+75 °C
Air humidity	H <sub>rel</sub>	max. 95%
Operating altitude		max. 4,000 m above sea level
Fastening and grounding		M12 threaded bolts and house base
Safety		Dry technology, over-pressure disconnecter, self-healing, max. permissible fault current 10,000 A per UL-810 standard
Discharging		Discharge resistors
Housing		Aluminium can and sheet steel housing
Protection class		IP20, indoor installation (optionally with IP54 terminal covering)
Dielectric		Polypropylene film
Impregnation		Dry
Number of switching cycles per year		Max. 60,000 switching cycles in accordance with IEC 60831 (with capacitor contactors)

\*1 Nominal voltage 400 V illustrated in the catalogue. 230 – 800 V on request.

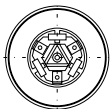
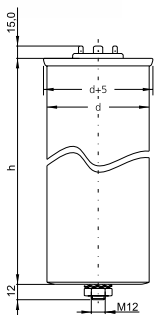
# 3-phase power capacitors in aluminium cans

**Main features**

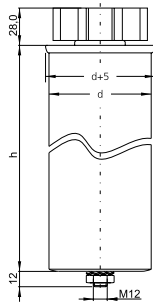
- PFC power capacitors in aluminium cans
- Delta connection
- With discharge resistors
- Long service life, low loss



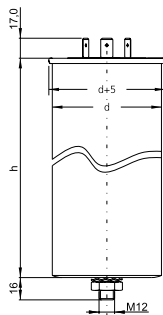
## Dimension diagrams



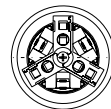
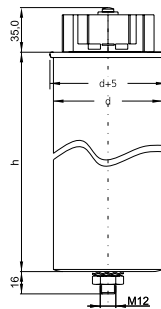
Capacitor with  
d = 60 / 70 mm  
for connection with  
flat connector  
6.3 x 0.8 mm



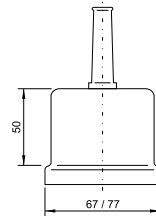
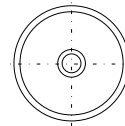
Capacitor with  
connection  
adapter ASS 1  
d = 60 / 70 mm



Capacitor with  
d = 85 mm  
for connection with  
flat connector 9.5 x 1.2 mm



Capacitor with  
connection  
adapter ASS 2  
d = 85 mm



Protective cap SK60 / SK70 for  
Capacitor with d = 60 / 70 mm  
(not available for capacitors  
with d = 85 mm)





## Technical data

Delta connection with discharge resistor - Protection type: IP00 – Frequency: 50 Hz									
Nominal output in kvar at a nominal voltage of:					Type	Capacitance in $\mu\text{F}$ -5 ... + 10%	Dimensions in mm (D x H)	Weight in kg	Item no.
400 V	415 V	440 V	480 V	525 V					
2.4	2.6	2.9	3.5	4.17	JCP525/4.1-D-ASS	3 x 16.0	60 x 225	0.7	19.02.275
2.5	2.7	3.0	3.6	4.3	JCP480/3.6-D-ASS	3 x 16.6	60 x 150	0.5	19.02.205
4.8	5.2	5.8	7	8.33	JCP525/8.3-D-ASS	3 x 32.0	70 x 225	0.9	19.02.249
5	5.4	6	7.2	8.6	JCP480/7.2-D-ASS	3 x 33.2	60 x 225	0.8	19.02.210
5.8	6.3	7	8.33	10	JCS525/10.0-D-ASS	3 x 38.5	70 x 225	0.8	19.02.150
6.25	6.7	7.6	9.0	-	JCP440/7.6-D-ASS	3 x 41.7	60 x 225	0.7	19.02.211
7.2	7.8	8.7	10.5	12.5	JCS525/12.5-D-ASS	3 x 48.1	70 x 225	1.1	19.02.180
8.7	9.4	10.5	12.5	15	JCS525/15.0-D-ASS	3 x 57.7	70 x 265	1.2	19.02.103
7.5	8.1	9.1	10.8	-	JCP440/9.1-D-ASS	3 x 49.9	60 x 225	0.7	19.02.215
10	10.8	12.1	14.4	-	JCP440/12.1-D-ASS	3 x 66.3	70 x 225	1.1	19.02.217
10.8	11.6	13.1	15.5	-	JCS480/15.5-D-ASS	3 x 71.4	70 x 225	1.1	19.02.116
9.3	10	11.2	-	-	JCP400/9.3-D-ASS	3 x 61.4	70 x 225	1.1	19.02.219
10	10.8	12.1	-	-	JCP400/10.0-D-ASS	3 x 66.3	70 x 225	1.1	19.02.220
11.7	12.5	14.1	-	-	JCP400/11.7-D-ASS	3 x 77.3	70 x 225	1.1	19.02.221
12.5	13.4	15.1	-	-	JCS440/15.0-D-ASS	3 x 82.9	70 x 225	1.1	19.02.125
20	-	24.2	-	-	JCP400/20.0-D-ASS	3 x 132.6	85 x 285	2.4	19.02.228
23.3	25.1	28.2	-	-	JCS440/28.2-D-ASS	3 x 154.6	85 x 355	2.5	19.02.126
25	29.9	30.2	-	-	JCS440/30.0-D-ASS	3 x 164.4	85 x 355	2.6	19.02.127



# AUTOMATIC POWER FACTOR CORRECTION SYSTEMS WITHOUT REACTORS

Optimised,  
thermal design



Self-healing



Low loss



Long service life



**High tolerance of start-up currents  
inrush current withstand capability**

- Optimised metal spraying process
- Wave-cut film design
- Capacitor contactors with pre-closing contacts for inrush current damping

**Long service life**

- Generous space- / power-ratio
- Generously dimensioned cooling system
- High quality capacitors

**High operational reliability**

- Capacitors with fivefold safety system
- PFC controller with 8-way alarm message
- Heavy duty sheet steel cabinets
- Optimised thermal design
- Exclusive use of quality components

## Areas of application



- Automatic Power Factor Correction (APFC)
- For use in mains supply with low harmonics distortion
- Converter power (non-linear loads) < 15% of total connection power
- Total harmonic distortion of THD-U < 3%
- No combined use in networks with de-tuned capacitors
- No use with critical ripple control systems in the range 270 to 425 Hz



## Device overview and technical data

Power factor correction without reactors		
Standards	DIN, VDE 0660 part 500, EN 60439-1 and EN 60831-1/2	
Design	DIN EN 60439 part 1, partial type-approved combination	
Construction type	Sheet steel cabinet for versions KB and ES, module for version MO	
PFC controller	Prophi® per datasheet or selection table	
Power capacitors	High quality, self-healing, polypropylene 3-phase capacitors using dry technology	
Contactors	Specific capacitor contactors with pre-charging resistors	
Capacitor protection	HRC fuses, 3-phase, per capacitor stage	
Nominal voltage	400 V, 50 Hz (other voltages on request)	
Control voltage	230 V, 50 Hz (other voltages on request)	
Output range	10 – 600 kvar (alternative staging, powers on request)	
Capacitor nominal voltage	440 V without reactors	
Voltage withstand capability of capacitors	8 h daily	484 V
	30 min daily	506 V
	5 min	528 V
	1 min	572 V
Power dissipation	Capacitors < 0.5 W/kvar, systems 4 – 7 W/kvar	
Switching cycles capacitor contactors	max. 100,000 switching cycles	
Current transformer connection	... /1 A, .../5 A	
Control ratio	See overview of variants	
Discharging	With discharge resistors per EN 60831-1/2	
Maximum altitude	Up to 2,000 m above sea level	
Ambient temperature	35 °C per DIN EN 60439 part 1 (temperature class of the capacitors should be assured with adequate ventilation/cooling at the place of installation!)	
Protection class	Cabinet version = IP32 / Slide-in module = IP00	
Type of cooling	Forced ventilation (except slide-in modules)	
Colour	Grey, RAL 7035 (other colours on request)	
Noise emission (FK)	< 60 dB with closed systems at 1 m distance	
Connection cross-section and fuse	See technical annex	

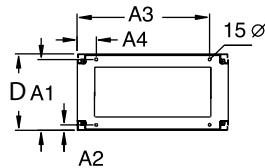
# Automatic power factor correction in modular design (up to 500 kvar ...)

## Main features

- APFC in the steel cabinet
- For free-standing installation
- Nominal voltage: 400 V, 3-phase, 50 Hz
- Protection class: IP32
- With natural convection (air exchange)
- With discharge resistors
- With power factor controller Prophi® 6R/12R



## Dimension diagrams



ES8184 (dimensions in mm):

H = 1820, W = 800, D = 400

A1 = 374, A2 = 25, A3 = 700, A4 = 100

A5 = 1,480



## Technical data

APFC in modular design ES8184							
Nominal output kvar	Stage power kvar	Control ratio	Type	Width in mm	Weight in kg	Item no.	
150	25/25/50/50	1:1:2:2	JF440/150ER6ES8184**	800	208	50.81.400	
150	12.5/12.5/25/50/50	1:1:2:4:4	JF440/150ER12ES8184**	800	208	50.81.415	
150	25/25/25...	1:1:1:1:1:1	JF440/150ER6ES8184**	800	208	50.81.425	
160	20/20/40...	1:1:2:2:2	JF440/160ER8ES8184**	800	209	50.81.450	
175	25/50/50/50	1:2:2:2	JF440/175ER7ES8184**	800	210	50.81.475	
175	12.5/12.5/25/25/50...	1:1:2:2:4:4	JF440/175ER14ES8184***	800	210	50.81.490	
180	20/40/40...	1:2:2:2:2	JF440/180ER9ES8184**	800	211	50.81.515	
200	50/50...	1:1:1:1	JF440/200ER4ES8184**	800	212	50.81.540	
200	25/25/50...	1:1:2:2:2	JF440/200ER8ES8184**	800	212	50.81.550	
200	12.5/12.5/25/50...	1:1:2:4:4...	JF440/200/ER16ES8184**	800	212	50.81.560	
200	20/20/40...	1:1:2:2:2:2	JF440/200ER10ES8184**	800	212	50.81.570	
240	20/20/40...	1:1:2:2...	JF440/240ER12ES8184***	800	232	50.81.600	
250	50...	1:1:1:1:1	JF440/250ER5ES8184**	800	233	50.81.625	
250	25/25/50...	1:1:2:2...	JF440/250ER10ES8184**	800	233	50.81.635	
250	12.5/12.5/25/50...	1:1:2:4:4...	JF440/250ER20ES8184***	800	233	50.81.645	
300	50/50...	1:1:1:1:1:1	JF440/300ER6ES8184**	800	236	50.81.670	
300	25/25/50...	1:1:2:2...	JF440/300ER12ES8184***	800	236	50.81.680	
300	12.5/12.5/25/50...	1:1:2:4:4...	JF440/300ER24ES8184***	800	236	50.81.690	
400	50/50/50...	1:1...	JF440/400ER8ES8184***	2 x 800	475	50.81.693	
500	50/50/50...	1:1...	JF440/500ER10ES8184***	2 x 800	500	50.81.696	
Accessories							
Socket 100 mm high	SO 100/800/400				5	29.03.317	
Socket 200 mm high	SO 200/800/400				10	29.03.322	

\*\* With power factor controller Prophi® 6R  
\*\*\* With power factor controller Prophi® 12R

Other rated voltages, frequencies, kvar-outputs, mechanical configurations or variants with circuit breakers on request. Expansion units, systems in ISO housing as well as audio frequency blocking devices on request.

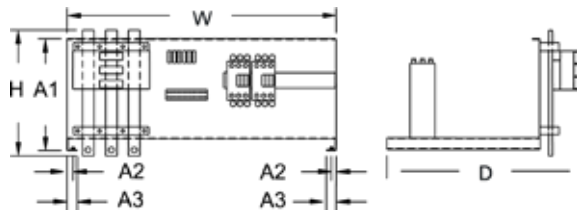
# Automatic power factor correction on extractable module, up to 100 kvar

## Main features

- Ready-to-install PFC slide-in modules without reactors
- For cabinet installation
- Nominal voltage: 400 V, 3-phase, 50 Hz
- Protection class: IP00
- With natural convection (air exchange)
- With discharge resistors



## Dimension diagrams



MO84 (dimensions in mm):  
 H = 330, W = 703, D = 333  
 A1 = 290, A2 = 14, A3 = 26.5



## Technical data

PFC module M084					
Nominal output kvar	Stage power kvar	Control ratio	Type	Weight in kg	Item no.
50	50		JF440/50EK1MO84	22	50.80.700
50	25/25	1:1	JF440/50/2EK2MO84	22	50.80.740
50	10/20/20	1:2:2	JF440/50/3EK5MO84	22	50.80.770
50	12.5/12.5/25	1:1:2	JF440/50/3/EK4MO84	22	50.80.774
60	20/40	1:2	JF440/60/2EK3MO84	23	50.80.775
60	10/10/20/20	1:1:2:2	JF440/60/4EK6MO84	23	50.80.776
75	25/50	1:2	JF440/75/2EK3MO84	24	50.80.800
75	25/25/25	1:1:1	JF440/75/3EK3MO84	24	50.80.810
75	12.5/12.5/25/25	1:1:2:2	JF440/75/4EK6MO84	24	50.80.811
80	40/40	1:1	JF440/80/2EK2MO84	24	50.80.835
80	20/20/40	1:1:2	JF440/80/3EK4MO84	24	50.80.837
100	50/50	1:1	JF440/100/2EK2MO84	25	50.80.875
100	25/25/50	1:1:2	JF440/100/3EK4MO84	25	50.80.880
100	25/25/25/25	1:1:1:1	JF440/100/4EK4MO84	25	50.80.900
100	20/40/40	1:2:2	JF440/100/3EK5MO84	25	50.80.902
100	12.5/12.5/25/50	1:1:2:4	JF440/100/4EK8MO84	25	50.80.903
<b>Control module with Prophi® 6R controller</b> MCCB, CT terminals and 2 m connection cable (mounted on the capacitor module)					50.80.003
<b>Control module with Prophi® 12R controller</b> MCCB, CT terminals and 2 m connection cable (mounted on the capacitor module)					50.80.004
<b>Accessories</b> Set module fixing rail for Rittal cabinets, left/right, with accessories (for Rittal cabinet MO84)					50.00.100

Other rated voltages, frequencies, outputs, mechanical configurations or variants with circuit breakers on request.

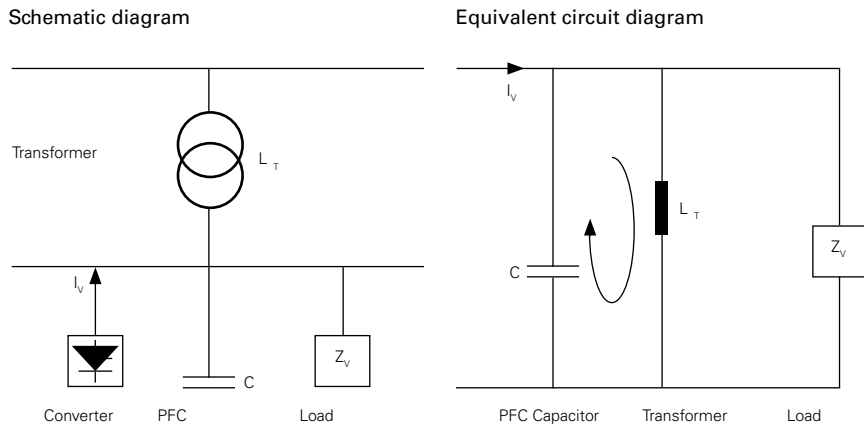


Fig.: Parallel resonant circuit between transformer and capacitors without reactors

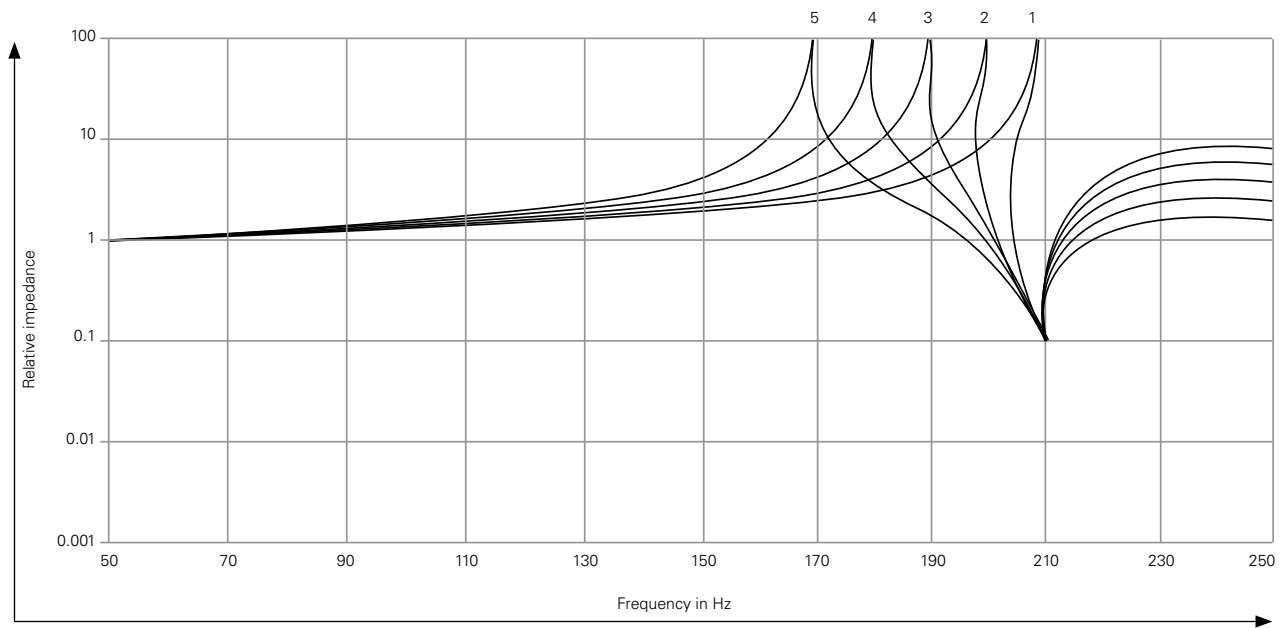


Fig.: Relative impedance progression for parallel resonant circuit with detuned capacitor and transformer

$U_k = 4\%$   
 $p = 5.67\%$   
 1... $Q_C / S_N = 5\%$   
 2... $Q_C / S_N = 15\%$   
 3... $Q_C / S_N = 30\%$   
 4... $Q_C / S_N = 50\%$   
 5... $Q_C / S_N = 80\%$   
 $Q_C = \text{PFC output}$   
 $S_N = \text{Apparent power of transformer}$





# AUTOMATIC DE-TUNED POWER FACTOR CORRECTION SYSTEMS



**Optimised filter design**

- Precise filter circuit frequency matching
- High quality reactors
- Temperature protection in the event of overload
- Filter circuit reactors with high linearity and low loss

**Long service life**

- Generous space- / power-ratio
- Generously dimensioned cooling system
- High quality capacitors and filter circuit reactors with 100% duty cycle

**High operational reliability**

- Capacitors with fivefold safety
- PFC controller with 8-way alarm message
- Optimised thermal design
- Exclusive use of quality components

## Areas of application



- Automatic power factor correction with reactors
- For use in mains supply with harmonics distortion
- Converter power (non-linear loads) > 15% of the connection power
- Total harmonic distortion of THD-U > 3%
- To prevent cases of resonance
- Harmonics filtering and improvement of power quality
- Reduction in reactive energy costs and PFC penalties



## Device overview and technical data

De-tuned power factor correction				
Technical data				
Standards	DIN, VDE 0660 part 500, EN 60439-1 and EN 60831-1/2			
Design in accordance with	DIN EN 60439 part 1, partial type-approved combination			
Construction type	Sheet steel cabinet for versions KB and ES, module for version MO			
Dynamic PFC controller	Prophi® per datasheet or selection table			
Power capacitors	High quality, self-healing, polypropylene 3-phase capacitors using dry technology			
Filter circuit reactors	Low-loss 3-phase reactors with high linearity, 7%, 14% (other ratings on request), with 100% duty cycle			
Contactors	Specific capacitor contactors			
Capacitor protection	HRC fuses, 3-phase, per capacitor stage			
Nominal voltage	400 V, 50 Hz (other voltages on request)			
Control voltage	230 V, 50 Hz (other voltages on request)			
Output range	10 – 600 kvar (alternative staging, outputs on request)			
Capacitor nominal voltage	440 V with 5.67 – 7% (detuned), 525 V with 14% (detuned)			
Voltage withstand capability of capacitors	At p = 5.67 – 7%	440 V	At p = 14%	525 V
	8 h daily	484 V		577 V
	30 min daily	506 V		604 V
	5 min	528 V		630 V
	1 min	572 V		682 V
Power dissipation	Capacitors < 0.5 W/kvar, systems 4 – 7 W/kvar			
System design	Permissible harmonics currents		Harmonics voltage	
	I 250 Hz	I 350 Hz	U 250 Hz	U 350 Hz
FK 5.67	0.565 IN	0.186 IN	5%	5%
FK 7	0.31 IN	0.134 IN	5%	5%
FK 14	0.086 IN	0.051 IN	5%	5%
Switching cycles capacitor contactors	max. 100,000 switching cycles			
Current transformer connection	... /1 A, .../5 A			
Control ratio	See overview of variants			
Discharging	With discharge resistors per EN 60831-1/2			
Maximum altitude	Up to 2,000 m above sea level			
Ambient temperature	35 °C per DIN EN 60439 part 1 (temperature class of the capacitors should be assured with adequate ventilation/cooling at the place of installation!)			
Protection class	Cabinet version = IP32 / Slide-in module = IP00			
Type of cooling	Forced ventilation (except slide-in modules)			
Colour	Grey, RAL 7035 (other colours on request)			
Noise emission (FK)	< 60 dB with closed systems at 1 m distance			
Connection cross-section and fuse	See technical annex			
The following reactors can be used in mains supply with ripple control systems:				
Ripple control frequency	De-tuning factor		Filter series resonant frequency	
< 168 Hz	p = 14%		fr = 134 Hz	
168 – 183 Hz	p = 14 / 5.67%		fr = 134 / 210 Hz	
> = 216.67	p = 8%		fr = 177 Hz	
> 228 Hz	p = 7%		fr = 189 Hz	
> 350 Hz	p = 5.67%		fr = 210 Hz	

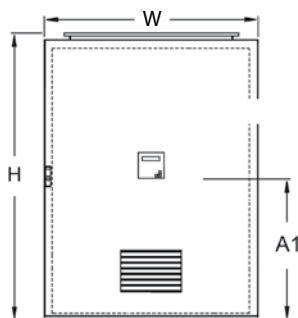
# Automatic de-tuned power factor correction (Harmonics filter), compact design

## Main features

- APFC in the steel cabinet
- For wall mounting
- Nominal voltage: 400 V, 3-phase, 50 Hz
- Reactors: 7% and 14%
- Protection class: IP32
- Ventilation: From 31 kvar with fan in the cabinet door for forced cooling
- With discharge resistors
- With power factor controller Prophi® 6R



## Dimension diagrams



KB6825 (dimensions in mm):

W = 600, H = 800, D = 250, A1 = 410

KB6123 (dimensions in mm):

W = 600, H = 1,200, D = 300, A1 = 655



## Technical data

### 7% de-tuned in accordance with series resonant frequency 189 Hz

Nominal output kvar	Stage power kvar	Control ratio	Type	Design	Weight in kg	Item no.
15	5/10	1:2	JF440/15ER3KB6825FK7	KB6825	112	50.52.020
20	5/5/10	1:1:2	JF440/20ER4KB6825FK7	KB6825	113	50.52.040
25	5/10/10	1:2:2	JF440/25ER5KB6825FK7	KB6825	116	50.52.080
31	6.25/12.5/12.5	1:2:2	JF440/31/ER5KB6825FK7	KB6825	118	50.52.110
35	5/10/20	1:2:4	JF440/35ER7KB6825FK7	KB6825	122	50.52.150
43.75	6.25/12.5/25	1:2:4	JF440/43.75ER7KB6825FK7	KB6825	138	50.52.180
50	10/20/20	1:2:2	JF440/50ER5KB6825FK7	KB6825	142	50.52.210
60	10/20/30	1:2:3	JF440/60ER6KB6123FK7	KB6123	158	50.52.225
75	12.5/25/37.5	1:2:3	JF440/75ER6KB6123FK7	KB6123	167	50.52.240

Other rated voltages, frequencies, outputs, reactors, mechanical configurations or variants with circuit breakers on request.

### 14% de-tuned in accordance with series resonant frequency 134 Hz

Nominal output kvar	Stage power kvar	Control ratio	Type	Design	Weight in kg	Item no.
15	5/10	1:2	JF525/15ER3KB6825FK14	KB6825	123	50.52.520
20	5/5/10	1:1:2	JF525/20ER4KB6825FK14	KB6825	124	50.52.540
25	5/10/10	1:2:2	JF525/25ER5KB6825FK14	KB6825	128	50.52.580
31	6.25/12.5/12.5	1:2:2	JF525/31/ER5KB6825FK14	KB6825	130	50.52.610
35	5/10/20	1:2:4	JF525/35ER7KB6825FK14	KB6825	134	50.52.650
43.75	6.25/12.5/25	1:2:4	JF525/43.75ER7KB6825FK14	KB6825	152	50.52.680
50	10/20/20	1:2:2	JF525/50ER5KB6825FK14	KB6825	173	50.52.710
60	10/20/30	1:2:3	JF525/60ER6KB6123FK14	KB6123	184	50.52.725
75	12.5/25/37.5	1:2:3	JF525/75ER6KB6123FK14	KB6123	195	50.52.729

Other rated voltages, frequencies, outputs, reactors, mechanical configurations or variants with circuit breakers on request.

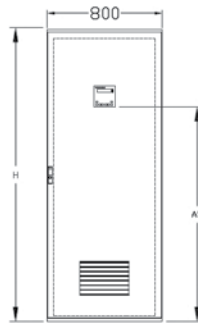
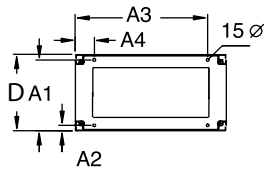
# 7% de-tuned power factor correction (harmonics filter), extractable design ES8206 FK7

**Main features**

- APFC in steel cabinet (free-standing mounting)
- Nominal voltage: 400 V, 3-phase, 50 Hz
- Reactor: 7% (189 Hz series resonant frequency)
- Protection class: IP32
- Ventilation: From 120 kvar with fan in the cabinet door for forced cooling
- With power factor controller Prophi® 6R/12R



## Dimension diagrams



ES8206 (dimensions in mm):  
 H = 2.020, W = 800 or 1.600, D = 600  
 A1 = 537, A2 = 63, A3 = 737, A4 = 62, A5 = 1,480



## Technical data

Nominal output kvar	Stage power kvar	Control ratio	Type	Width in mm	Weight in kg	Item no.
60	10/20/30	1:2:3...	JF440/60ER6ES8206FK7**	800	278	50.89.040
75	12.5/12.5/25...	1:1:2...	JF440/75ER6ES8206FK7**	800	278	50.89.080
100	25/25/50	1:1:2	JF440/100ER4ES8206FK7**	800	288	50.89.120
100	12.5/12.5/25/50	1:1:2:4	JF440/100ER8ES8206FK7**	800	288	50.89.200
120	20/20/40/40	1:1:2:2	JF440/120ER6ES8206FK7**	800	340	50.89.320
150	25/25/50/50	1:1:2:2	JF440/150ER6ES8206FK7**	800	344	50.89.400
175	25/50/50/50	1:2:2:2	JF440/175ER7ES8206FK7**	800	367	50.89.440
200	50...	1:1:1...	JF440/200ER4ES8206FK7**	800	314	50.89.480
200	25/25/50...	1:1:2...	JF440/200ER8ES8206FK7**	800	314	50.89.520
200	12.5/12.5/25/50...	1:1:2:4..	JF440/200ER16ES8206FK7**	800	314	50.89.560
250	50...	1:1:1...	JF440/250ER5ES8206FK7**	800	437	50.89.600
250	25/25/50...	1:1:2...	JF440/250ER10ES8206FK7**	800	437	50.89.640
300	50...	1:1:1...	JF440/300ER6ES8206FK7**	800	487	50.89.685
300	25/25/50...	1:1:2...	JF440/300ER12ES8206FK7***	800	498	50.89.687
350	50...	1:1:1...	JF440/350ER7ES8206FK7-1S***	800	520	50.89.720
350	50...	1:1:1...	JF440/350ER7ES8206FK7***	1,600	352/347	50.89.722
400	50...	1:1:1...	JF440/400ER8ES8206FK7-1S***	800	570	50.89.744
400	50...	1:1.1...	JF440/400ER8ES8206FK7***	1,600	2x370	50.89.740
450	50...	1:1:1...	JF440/450ER9ES8206FK7***	1,600	437/347	50.89.770
500	50...	1:1:1...	JF440/500ER10ES8206FK7***	1,600	479/359	50.89.800
550	50...	1:1:1...	JF440/550ER11ES8206FK7***	1,600	2x431	50.89.805
600	50...	1:1:1...	JF440/600ER12ES8206FK7***	1,600	2x481	50.89.820

Accessories						
100 mm high socket for easy supply cable connection	SO 100 / 800 / 600				5	50.00.150
200 mm high socket for easy supply cable connection	SO 200 / 800 / 600				10	50.00.151

Other rated voltages, frequencies, outputs, reactors, mechanical configurations or variants with circuit breakers on request.  
 \*\* With Prophi® 6R, \*\*\* With Prophi® 12R

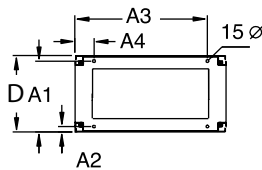
# 14% de-tuned power factor correction (harmonics filter), extractable design ES8206 FK14

## Main features

- APFC in steel cabinet (free-standing mounting)
- Nominal voltage: 400 V, 3-phase, 50 Hz
- Reactors: 14% (134 Hz series resonant frequency)
- Protection class: IP32
- Ventilation: From 120 kvar with fan in the cabinet door for forced cooling
- With power factor controller Prophi® 6R/12R



## Dimension diagrams



ES8206 (dimensions in mm):

H = 2.020, W = 800 or 1.600, D = 600

A1 = 537, A2 = 63, A3 = 737, A4 = 62, A5 = 1,480



## Technical data

Nominal output kvar	Stage power kvar	Control ratio	Type	Width in mm	Weight in kg	Item no.
60	10/20/30	1:2:3	JF525/60ER6ES8206FK14**	800	317	50.93.040
75	12.5/12.5/25/25	1:1:2:2	JF525/75ER6ES8206FK14**	800	318	50.93.080
100	25/25/50	1:1:2	JF525/100ER4ES8206FK14**	800	368	50.93.120
100	12.5/12.5/25/50	1:1:2:4	JF525/100ER8ES8206FK14**	800	380	50.93.200
120	20/20/40/40	1:1:2:2	JF525/120ER6ES8206FK14**	800	379	50.93.320
150	25/25/50/50	1:1:2:2	JF525/150ER6ES8206FK14**	800	375	50.93.400
175	25/50/50/50	1:2:2:2	JF525/175ER7ES8206FK14**	800	407	50.93.440
200	50	1:1:1:1	JF525/200ER4ES8206FK14**	800	420	50.93.480
200	25/25/50...	1:1:2...	JF525/200ER8ES8206FK14**	800	421	50.93.520
200	12.5/12.5/25/50...	1:1:2:4...	JF525/200ER16ES8206FK14**	800	371	50.93.560
250	50	1:1:1...	JF525/250/ER5ES8206FK14**	800	478	50.93.600
250	25/25/50...	1:1:2...	JF525/250ER10ES8206FK14**	800	490	50.93.640
300	50	1:1:1...	JF525/300ER6ES8206FK14**	800	500	50.93.685
300	25/25/50...	1:1:2...	JF525/300ER12ES8206FK14***	800	500	50.93.690
350	50...	1:1:1...	JF525/350ER7ES8206FK14-S***	800	550	50.93.720
350	50...	1:1:1...	JF525/350ER7ES8206FK14***	1,600	424/365	50.93.722
400	50...	1:1:1...	JF525/400ER8ES8206FK14-S***	800	600	50.93.740
400	50...	1:1:1...	JF525/400ER8ES8206FK14***	1,600	2x424	50.93.742
450	50...	1:1:1...	JF525/450ER9ES8206FK14***	1,600	2x478	50.93.770
500	50...	1:1:1...	JF525/500ER10ES8206FK14***	1,600	500/420	50.93.800
550	50...	1:1:1...	JF525/550ER11ES8206FK14***	1,600	500/478	50.93.805
600	50...	1:1:1...	JF525/600ER12ES8206FK14***	1,600	500/500	50.93.920

### Accessories

100 mm high socket for easy supply cable connection	SO 100 / 800 / 600	5	50.00.150
200 mm high socket for easy supply cable connection	SO 200 / 800 / 600	10	50.00.151

Other rated voltages, frequencies, outputs, reactors, mechanical configurations or variants with circuit breakers on request.

\*\* With Prophi® 6R, \*\*\* With Prophi® 12R

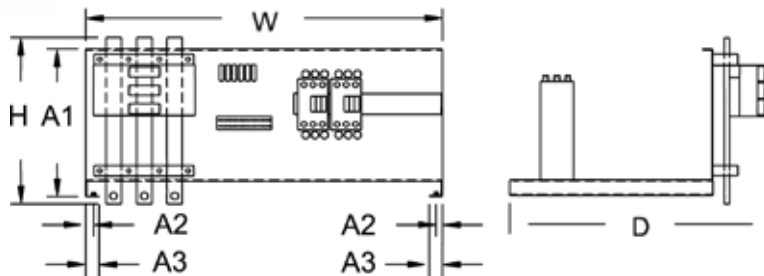
# De-tuned capacitor modules, extractable design

## Main features

- Ready-to-install, de-tuned PFC slide-in modules
- Completely mounted and wired with capacitors, reactors, contactors and HRC-fuses
- For slide-in installation in existing PFC or switchgear cabinets
- Nominal voltage: 400 V, 3-phase, 50 Hz
- Reactors: 7% (189 Hz) and 14% (134 Hz)
- Protection class: IP32
- Ventilation: Natural (care must be taken to ensure sufficient ventilation)
- With discharge resistors



## Dimension diagrams



Dimensions in mm:

H = 330, W = 703, D = 533

A1 = 290, A2 = 14, A3 = 26.5



## Technical data

7% de-tuned capacitor modules (189 Hz) MO86FK7 (width 800 mm, depth 600 mm)					
Nominal output kvar	Stage power kvar	Control ratio	Type	Weight in kg	Item no.
10	10		JF440/10EK1MO86FK7	24	50.88.650
12.5	12.5		JF440/12.5EK1MO86FK7	26	50.88.680
20	20		JF440/20EK1MO86FK7	33	50.88.710
25	25		JF440/25/EK1MO86FK7	33	50.88.740
40	40		JF440/40EK1MO86FK7	43	50.88.770
50	50		JF440/50EK1MO86FK7	45	50.88.800
20/2	10	1:1	JF440/20/2EK2MO86FK7	36	50.88.801
25/2	12.5	1:1	JF440/25/2EK2MO86FK7	38	50.88.830
30/2	10/20	1:2	JF440/30/2EK2MO86FK7	42	50.88.860
40/2	20	1:1	JF440/40/2EK2MO86FK7	55	50.88.890
40/3	10/10/20	1:1:2	JF440/40/3EK2MO86FK7	55	50.88.891
50/2	25	1:1	JF440/50/2EK2MO86FK7	56	50.88.930
75/2	25/50	1:2	JF440/75/2EK2MO86FK7	72	50.88.932
80/2	40	1:1	JF440/80/2EK2MO86FK7	72	50.88.933
100/2	50	1:1	JF440/100/2EK2MO86FK7	86	50.88.931

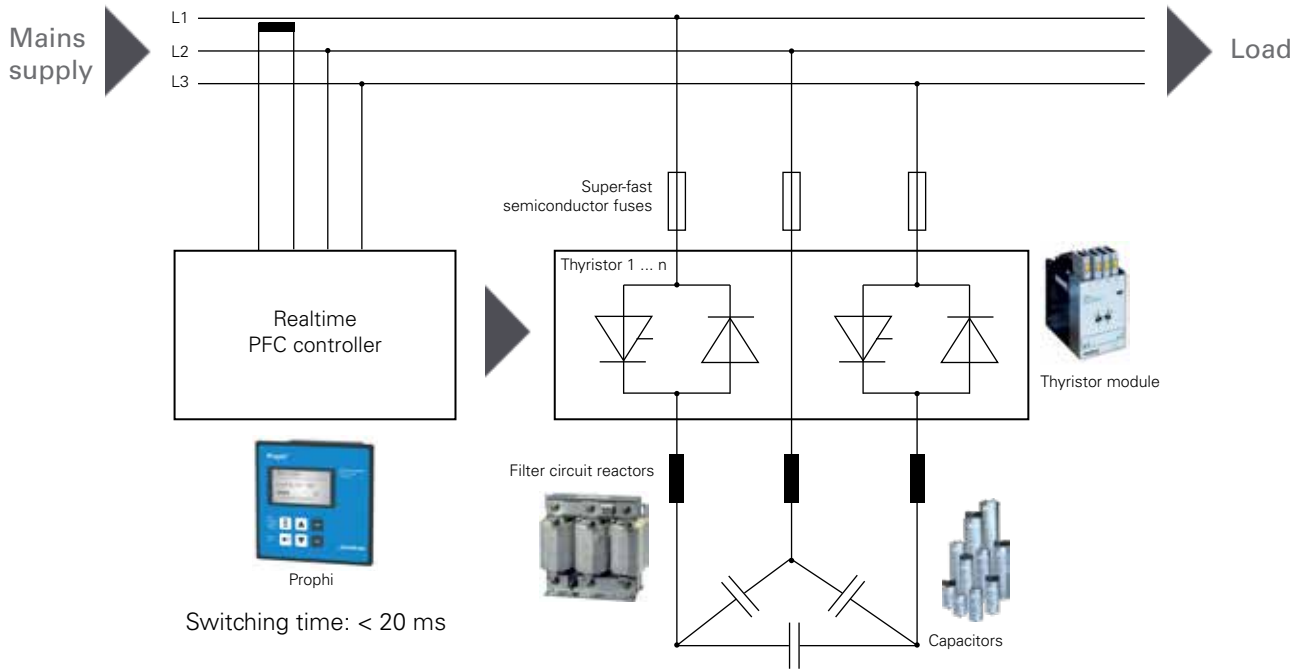
Other rated voltages, frequencies, outputs, reactors, mechanical configurations (e.g. 500 mm switch cabinet depth) or variants with circuit breakers on request. Accessories, see page 273.

14% de-tuned capacitor modules (134 Hz) MO86FK14 (width 800 mm, depth 600 mm)					
Nominal output kvar	Stage power kvar	Control ratio	Type	Weight in kg	Item no.
10	10		JF525/10EK1MO86FK14	34	50.92.650
12.5	12.5		JF525/12.5EK1MO86FK14	35	50.92.680
20	20		JF525/20EK1MO86FK14	40	50.92.710
25	25		JF525/25EK1MO86FK14	40	50.92.740
40	40		JF525/40EK1MO86FK14	52	50.92.770
50	50		JF525/50EK1MO86FK14	54	50.92.800
20/2	10	1:1	JF525/20/2E2MO86FK14	53	50.92.803
25/2	12.5	1:1	JF525/25/2EK2MO86FK14	60	50.92.804
30/2	10/20	1:2	JF525/30/2EK2MO86FK14	45	50.92.849
40/2	20	1:1	JF525/40/2EK2MO86FK14	67	50.92.850
40/3	10/10/20	1:1:2	JF525/40/3EK3MO86FK14	72	50.92.851
50/2	25	1:1	JF525/50/2EK2MO86FK14	69	50.92.890
75/2	25/50	1:2	JF525/75/2EK2MO86FK14	78	50.92.893
80/2	40	1:1	JF525/80/2EK2MO86FK14	78	50.92.896
100/2	50	1:1	JF525/100/2EK2MO86FK14	92	50.92.892

Other rated voltages, frequencies, outputs, reactors, mechanical configurations or variants (e.g. 500 mm switch cabinet depth) with circuit breakers on request. Accessories, see page 273.

# Chapter 08

## Dynamic power factor correction systems (real time PFC)





# DYNAMIC POWER FACTOR CORRECTION SYSTEMS (REAL TIME PFC)

Optimised,  
thermal design



De-tuned version



Long service life



Minimised  
grid distortion

## Hardly any mains supply distortion

- Switching at zero point transition
- No inrush currents
- Stabilisation of the mains supply voltage
- Reduction of harmonics distortion
- Switching times < 20 ms

## Long service life

- Generous space- / power-ratio
- Generously dimensioned cooling system
- High quality capacitors and filter circuit reactors

## High operational reliability

- Capacitors with fivefold safety
- PFC controller with 8-way alarm message
- Filter circuit reactors with high linearity and 100% duty cycle
- Optimised thermal design
- Exclusive use of quality components
- Thyristor switch for capacitor connection without mains supply distortion



## Areas of application

- Use in applications with fast and high load changes
- APFC in LVDB
- For use in mains supply with harmonics burden
- Converter power (non-linear loads) > 15% of the connection power
- Total harmonic distortion of THD-U > 3%
- Harmonics filtering and improvement of power quality
- Reduction in reactive current costs
- Stabilisation of the mains supply voltage

## Typical applications

- Automotive industry (welding systems, presses, etc.)
- Lift systems and cranes
- Start-up compensation for large motors
- Drilling rigs in oil production
- Wind turbines
- Welding technology
- Steel production
- Plastic injection moulding systems
- Fishing vessels

## Particular advantages

- Improved power quality, i.e. avoidance of high start-up currents for the power capacitors
- Significant extending the service life for the PFC system
- Safety of the complete system is significantly increased (i.e. avoidance of damages through defective contactors and subsequent exploding capacitors)
- Ultra-fast compensation of power factor, resulting in a reduction in the reactive current costs and kWh losses
- Voltage stabilisation (e.g. contactors support during the start-up phase of large motors)
- Improved utilisation of the energy distribution (transformers, cabling, switchgear, etc.) through the elimination of power peaks
- Shortening of process times (e.g. welding) due to stabilized voltage

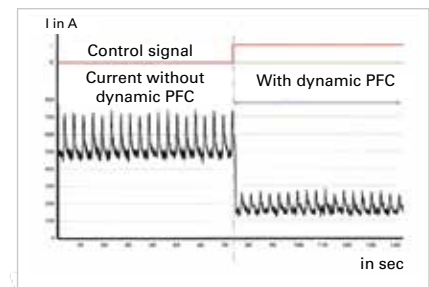


Fig.: Current reduction by means of dynamic PFC

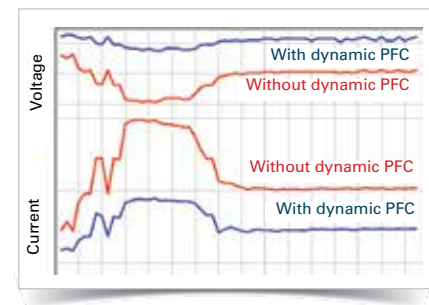


Fig.: Comparison of current and voltage with and without dynamic PFC when starting up a large motor



## Device overview and technical data

Dynamic power factor correction				
Technical data				
Standards	DIN, VDE 0660 part 500, EN 60439-1 and EN 60831-1/2			
Design in accordance with	DIN EN 60439 part 1, partial type-approved combination			
Construction type	Sheet steel cabinet for versions KB and ES, module for version MO			
Dynamic power factor controller	Prophi®T version per datasheet or selection table			
Power capacitors	High quality, self-healing, polypropylene 3-phase capacitors using dry technology			
Filter circuit reactors	Low-loss 3-phase reactors with high linearity, 7%, 14% (other reactor ratings on request)			
Electronic switch (t < 20 ms)	Thyristor actuator for switching in the zero point transition (to avoid network disturbances)			
Capacitor protection	Ultra-fast electronic fuses			
Nominal voltage	400 V, 50 Hz (other voltages on request)			
Control voltage	230 V, 50 Hz (other voltages on request)			
Output range	10 – 600 kvar (alternative staging, outputs on request)			
Capacitor nominal voltage	440 V with out reactors and 5.67 – 7% (choked), 525 V with 14% (reactors)			
Voltage withstand capability of capacitors	At p = 5.67 – 7%	440 V	At p = 14%	525 V
	8 h daily	484 V		577 V
	30 min daily	506 V		604 V
	5 min	528 V		630 V
	1 min	572 V		682 V
Power dissipation	Capacitors < 0.5 W/kvar, systems 4 – 7 W/kvar			
System design	Permissible harmonics currents		Harmonics voltage	
	I 250 Hz	I 350 Hz	U 250 Hz	U 350 Hz
FK 5.67	0.565 IN	0.186 IN	5%	5%
FK 7	0.31 IN	0.134 IN	5%	5%
FK 14	0.086 IN	0.051 IN	5%	5%
Current transformer connection	... /1 A, .../5 A			
Control ratio	See overview of variants			
Discharging	With discharge resistors per EN 60831-1/2			
Maximum altitude	Up to 2,000 m above sea level			
Ambient temperature	35 °C per DIN EN 60439 part 1 (temperature class of the capacitors should be assured with adequate ventilation/cooling at the place of installation!)			
Protection class	Cabinet version = IP32 / Slide-in module = IP00			
Type of cooling	Forced ventilation (except slide-in modules)			
Colour	Grey, RAL 7035			
Noise emission (FK)	< 60 dB with closed systems at 1 m distance			
Connection cross-section and fuse	See technical annex			

The following reactors can be used in mains supply with ripple control systems:		
Mains supply ripple control frequency	De-tuning factor	Filter series resonant frequency
< 168 Hz	p = 14%	fr = 134 Hz
168 – 183 Hz	p = 14 / 5.67%	fr = 134 / 210 Hz
> = 216.67	p = 8%	fr = 177 Hz
> 228 Hz	p = 7%	fr = 189 Hz
> 350 Hz	p = 5.67%	fr = 210 Hz

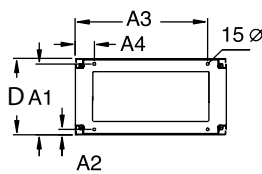
# 7% de-tuned dynamic power factor correction, extractable design ES8206 FKTh

## Main features

- Dynamic ( $t < 20$  ms), de-tuned APFC in extractable design in steel cabinet
- Modular cabinet for free-standing mounting (expandable in output)
- Nominal voltage: 400 V, 3-phase, 50 Hz
- Reactors: 7% (189 Hz series resonant frequency)
- Protection class: IP32
- Ventilation: From 120 kvar with fan in PFC cabinet door for forced cooling
- With power factor controller Prophi® 6T / 12T



## Dimension diagrams



ES8206 (dimensions in mm):  
 H = 2,020, W = 800, D = 600, A1 = 537  
 A2 = 63, A3 = 737, A4 = 62, A5 = 1,480



## Technical data

Nominal output kvar	Stage power kvar	Control ratio	Type	Width in mm	Weight in kg	Item no.
60	10/20/30	1:2:3	JF440/60ER6ES8206FK7Th**	800	290	50.19.040
75	12.5/12.5/25/25	1:1:2:2	JF440/75ER6ES8206FK7Th**	800	290	50.19.080
100	25/25/50	1:1:2	JF440/100ER4ES8206FK7Th**	800	306	50.19.120
120	20/20/40/40	1:1:2:2	JF440/120/ER6ES8206FK7Th**	800	306	50.19.320
100	12.5/12.5/25/50	1:1:2:4	JF440/100ER8ES8206FK7Th**	800	380	50.19.200
125	12.5/25/37.5/50	1:2:3:4	JF440/125ER10ES8206FK7Th**	800	390	50.19.325
150	12.5/12.5/25/50...	1:1:2:4...	JF440/150ER12ES8206FK7Th**	800	410	50.19.330
150	25/25/50/50	1:1:2:2	JF440/150ER6ES8206FK7Th**	800	410	50.19.400
175	12.5/25/37.5/50...	1:2:3:4...	JF440/175ERES8206FK7Th**	800	420	50.19.440
200	50/50/50/50	1:1:1:1	JF440/200ER4ES8206FK7Th**	800	430	50.19.480
200	25/25/50...	1:1:2...	JF440/200ER8ES8206FK7Th**	800	430	50.19.520
200	12.5/12.5/25/50...	1:1:2:4...	JF440/200ER16ES8206FK7Th**	800	435	50.19.560
250	50/50...	1:1...	JF440/250ER5ES8206FK7Th**	800	478	50.19.600
250	25/25/50...	1:1:2...	JF440/250ER10ES8206FK7Th**	800	490	50.19.640
250	12.5/12.5/25/50...	1:1:2:4...	JF440/250ER20ES8206FK7Th***	800	495	50.19.645
300	50/50...	1:1...	JF440/300ER6ES8206FK7Th**	800	500	50.19.685
300	25/25/50...	1:1:2...	JF440/300ER12ES8206FK7Th***	800	500	50.19.690
400	50/50...	1:1...	JF440/400ER8ES8206FK7Th***	1,600	2 x 421	50.19.742
500	50/50...	1:1...	JF440/500ER10ES8206FK7Th***	1,600	500 / 421	50.19.800
600	50/50...	1:1...	JF440/600ER12ES8206FK7Th***	1,600	2 x 500	50.19.820

Accessories						
100 mm high socket for easy supply cable connection	SO 100 / 800 / 600			5		50.00.150
200 mm high socket for easy supply cable connection	SO 200 / 800 / 600			10		50.00.151

Other rated voltages, frequencies, outputs, reactors, mechanical configurations or variants with circuit breakers on request.  
 \*\* With Prophi® 6T, \*\*\* With Prophi® 12T

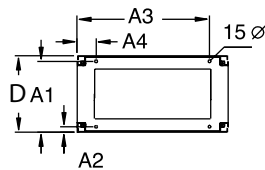
# 14% de-tuned dynamic power factor correction, extractable design ES8206 Th

## Main features

- Dynamic ( $t < 20$  ms), de-tuned APFC in extractable design in steel cabinet
- Modular cabinet for free-standing mounting (expandable in output)
- Nominal voltage: 400 V, 3-phase, 50 Hz
- Reactors: 14% (134 Hz series resonant frequency)
- Protection class: IP32
- Ventilation: From 120 kvar with fan in PFC cabinet door for forced cooling
- With power factor controller Prophi® 6T / 12T



## Dimension diagrams



ES8206 (dimensions in mm):

H = 2,020, W = 800, D = 600, A1 = 537

A2 = 63, A3 = 737, A4 = 62, A5 = 1,480



## Technical data

Nominal output kvar	Stage power kvar	Control ratio	Type	Width in mm	Weight in kg	Item no.
60	10/20/30	1:2:3	JF525/60ER6ES8206FK14Th*	800	290	50.98.040
75	12.5/12.5/25/25	1:1:2:2	JF525/75ER6ES8206FK14Th**	800	290	50.98.080
100	25/25/50	1:1:2	JF525/100ER4ES8206FK14Th**	800	306	50.98.120
120	20/20/40/40	1:1:2:2	JF525/120/ER6ES8206FK14Th**	800	306	50.98.320
100	12.5/12.5/25/50	1:1:2:4	JF525/100ER8ES8206FK14Th**	800	380	50.98.200
125	12.5/25/37.5/50	1:2:3:4	JF525/125ER10ES8206FK14Th**	800	390	50.98.325
150	12.5/12.5/25/50...	1:1:2:4...	JF525/150ER12ES8206FK14Th**	800	410	50.98.330
150	25/25/50/50	1:1:2:2	JF525/150ER6ES8206FK14Th**	800	410	50.98.400
175	12.5/25/37.5/50...	1:2:3:4...	JF525/175ERES8206FK14Th**	800	420	50.98.440
200	50/50/50/50	1:1:1:1	JF525/200ER4ES8206FK14Th**	800	430	50.98.480
200	25/25/50...	1:1:2...	JF525/200ER8ES8206FK14Th**	800	430	50.98.520
200	12.5/12.5/25/50...	1:1:2:4...	JF525/200ER16ES8206FK14Th**	800	435	50.98.560
250	50/50...	1:1...	JF525/250ER5ES8206FK14Th**	800	478	50.98.600
250	25/25/50...	1:1:2...	JF525/250ER10ES8206FK14Th**	800	490	50.98.640
250	12.5/12.5/25/50...	1:1:2:4...	JF525/250ER20ES8206FK14Th***	800	495	50.98.645
300	50/50...	1:1...	JF525/300ER6ES8206FK14Th**	800	500	50.98.685
300	25/25/50...	1:1:2...	JF525/300ER12ES8206FK14Th***	800	500	50.98.690
400	50/50...	1:1...	JF525/400ER8ES8206FK14Th***	1,600	2 x 421	50.98.742
500	50/50...	1:1...	JF525/500ER10ES8206FK14Th***	1,600	500 / 421	50.98.800
600	50/50...	1:1...	JF525/600ER12ES8206FK14Th***	1,600	2 x 500	50.98.920

### Accessories

100 mm high socket for easy supply cable connection	SO 100 / 800 / 600	5	50.00.150
200 mm high socket for easy supply cable connection	SO 200 / 800 / 600	10	50.00.151

Other rated voltages, frequencies, powers, reactors, mechanical configurations or variants with circuit breakers on request.

\*\* With Prophi® 6R, \*\*\* With Prophi® 12R

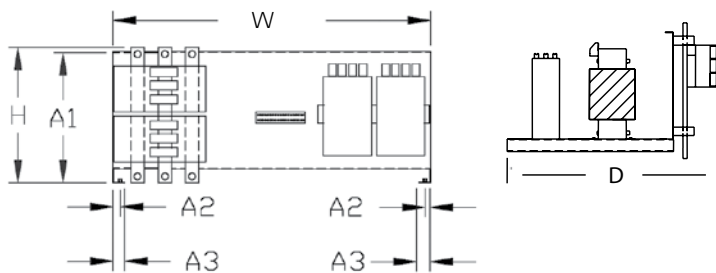
# De-tuned, dynamic PFC modules extractable design

## Main features

- Dynamic ( $t < 20$  ms), de-tuned APFC in extractable design in steel cabinet
- For installation in existing switch gear or PFC cabinets
- Nominal voltage: 400 V, 3-phase, 50 Hz
- Reactors: 7% (189 Hz series resonant frequency),  
14% (134 Hz series resonant frequency)
- Protection class: IP32
- Ventilation: Natural cooling  
(care must be taken to ensure sufficient ventilation)
- With discharge resistors



## Dimension diagrams



dimensions in mm:

H = 330, W = 703, D = 550

A1 = 290, A2 = 14, A3 = 26.5



## Technical data

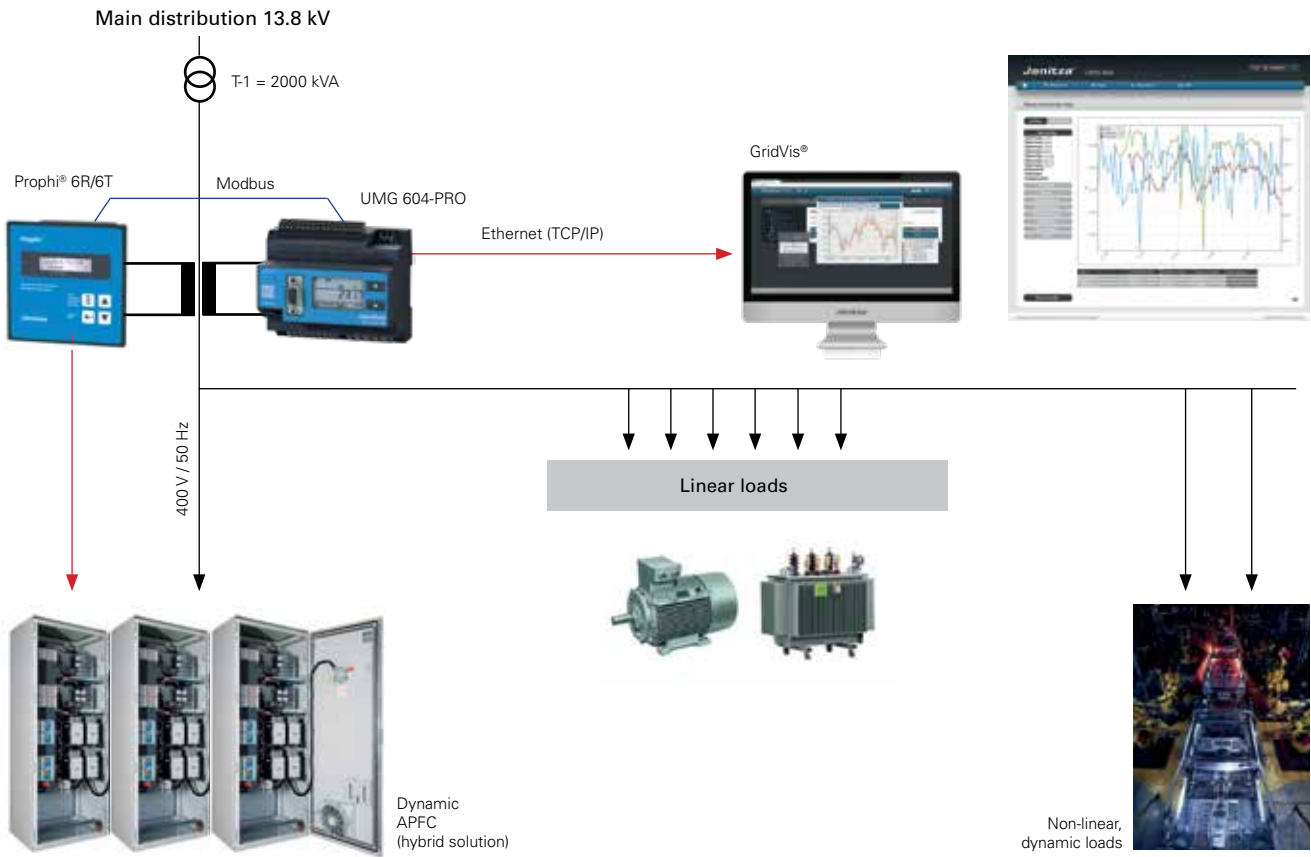
7% de-tuned capacitor modules MO86FK7Th (width 800 mm, depth 600 mm)					
Nominal output kvar	Stage power kvar	Control ratio	Type	Weight in kg	Item no.
10	10		JF440/10EK1MO86FK7Th	26	50.18.650
12.5	12.5		JF440/12.5EK1MO86FK7Th	28	50.18.680
20	20		JF440/20EK1MO86FK7Th	35	50.18.710
25	25		JF440/25/EK1MO86FK7Th	35	50.18.740
40	40		JF440/40EK1MO86FK7Th	45	50.18.770
50	50		JF440/50EK1MO86FK7Th	47	50.18.800
20/2	10	1:1	JF440/20/2EK2MO86FK7Th	40	50.18.801
25/2	12.5	1:1	JF440/25/2EK2MO86FK7Th	42	50.18.830
30/2	10/20	1:2	JF440/30/2EK2MO86FK7Th	46	50.18.860
40/2	20	1:1	JF440/40/2EK2MO86FK7Th	57	50.18.890
50/2	25	1:1	JF440/50/2EK2MO86FK7Th	58	50.18.930
75/2	25/50	1:2	JF440/75/2EK2MO86FK7Th	76	50.18.932
80/2	40/40	1:1	JF440/80/2EK2MO86FK7Th	77	50.18.933
100/2	50/50	1:1	JF440/100/2EK2MO86FK7Th	90	50.18.931

14% de-tuned capacitor modules MO86FK14Th (width 800 mm, depth 600 mm)					
Nominal output kvar	Stage power kvar	Control ratio	Type	Weight in kg	Item no.
10	10		JF525/10EK1MO86FK14Th	36	50.12.650
12.5	12.5		JF525/12.5EK1MO86FK14Th	37	50.12.680
20	20		JF525/20EK1MO86FK14Th	42	50.12.710
25	25		JF525/25EK1MO86FK14Th	43	50.12.740
40	40		JF525/40EK1MO86FK14Th	54	50.12.770
50	50		JF525/50EK1MO86FK14Th	56	50.12.800
20/2	10	1:1	JF525/20/2EK2MO86FK14Th	57	50.12.803
25/2	12.5	1:1	JF525/25/2EK2MO86FK14Th	64	50.12.804
30/2	10/20	1:2	JF525/30/2EK2MO86FK14Th	69	50.12.849
40/2	20	1:1	JF525/40/2EK2MO86FK14Th	71	50.12.850
50/2	25	1:1	JF525/50/2EK2MO86FK14Th	73	50.12.890
75/2	25/50	1:2	JF525/75/2EK2MO86FK14Th	82	50.12.893
80/2	40/40	1:1	JF525/80/2EK2MO86FK14Th	84	50.12.896
100/2	50/50	1:1	JF525/100/2EK2MO86FK14Th	96	50.12.892

Other rated voltages, frequencies, outputs, reactors, mechanical configurations or variants with circuit breakers on request.

# Chapter 08

## Communications architecture: PFC and power quality analysis combined





# POWER FACTOR CORRECTION SPARE PARTS AND ACCESSORIES

Reactors



Capacitors



Capacitor contactors



HRC fuses



# Component selection table for a nominal voltage 400 V – 50 Hz

De-tuned power factor correction							
De-tuning factor %	Reactive output in kvar	Capacitor Item no.	Filter circuit reactors Item no.	Capacitor contactor Item no.	Cable diameter (mm <sup>2</sup> )	HRC fuse socket Item no.	HRC fuses Item no.
7	2.50	1 x JCP525 / 4.17-D 19.02.275	FKD 2.50 kvar / 7% 04.01.500	KS 12.5 kvar / K3-18ND10230 01.02.025	4	NH / RSUmB / Gr00 / 3p 05.03.002	NHS10Gr00 05.05.000
7	5.00	1 x JCP525 / 8.33-D 19.02.249	FKD 5.00 kvar / 7% 04.01.509	KS 12.5 kvar / K3-18ND10230 01.02.025	4	NH / RSUmB / Gr00 / 3p 05.03.002	NHS10Gr00 05.05.000
7	6.25	1 x JCS525 / 10.0-D 19.02.150	FKD 6.25 kvar / 7% 04.01.510	KS 12.5 kvar / K3-18ND10230 01.02.025	4	NH / RSUmB / Gr00 / 3p 05.03.002	NHS16Gr00 05.05.001
7	10.00	1 x JCP400 / 9.30-D 19.02.219	FKD 10.0 kvar / 7% 04.01.501	KS 12.5 kvar / K3-18ND10230 01.02.025	10	NH / RSUmB / Gr00 / 3p 05.03.002	NHS25Gr00 05.05.002
7	12.50	1 x JCP400 / 11.7-D 19.02.221	FKD 12.5 kvar / 7% 04.01.502	KS 12.5 kvar / K3-18ND10230 01.02.025	10	NH / RSUmB / Gr00 / 3p 05.03.002	NHS25Gr00 05.05.002
7	15.00	1 x JCP400 / 9.30-D 19.02.221 1 x JCP525 / 8.30-D 19.02.249	FKD 15 kvar / 7% 04.01.512	KS 20.0 kvar / K3-24A00230 01.02.026	10	NH / RSUmB / Gr00 / 3p 05.03.002	NHS35Gr00 05.05.003
7	20.00	2 x JCP400 / 9.30-D 19.02.219	FKD 20.0 kvar / 7% 04.01.503	KS 20.0 kvar / K3-24A00230 01.02.026	10	NH / RSUmB / Gr00 / 3p 05.03.002	NHS50Gr00 05.05.004
7	25.00	2 x JCP400 / 11.7-D 19.02.221	FKD 25.0 kvar / 7% 04.01.504	KS 25.0 kvar / K3-32A00230 01.02.027	16	NH / RSUmB / Gr00 / 3p 05.03.002	NHS63Gr00 05.05.005
7	30.00	3 x JCP400 / 9.30-D 19.02.219	FKD 30.0 kvar / 7% 04.01.505	KS 50.0 kvar / K3-62A00230 01.02.029	35	NH / RSUmB / Gr00 / 3p 05.03.002	NHS63Gr00 05.05.005
7	40.00	3 x JCS440 / 15.0-D 19.02.125	FKD 40.0 kvar / 7% 04.01.506	KS 50.0 kvar / K3-62A00230 01.02.029	35	NH / RSUmB / Gr00 / 3p 05.03.002	NHS100Gr00 05.05.007
7	50.00	4 x JCP400 / 11.7-D 19.0.2221	FKD 50.0 kvar / 7% 04.01.507	KS 50.0 kvar / K3-62A00230 01.02.029	50	NH / RSUmB / Gr00 / 3p 05.03.002	NHS125Gr00 05.05.008
14	2.50	1 x JCP525 / 4.17-D 19.02.275	FKD 2.50 kvar / 14% 04.01.525	KS 12.5 kvar / K3-18ND10230 01.02.025	4	NH / RSUmB / Gr00 / 3p 05.03.002	NHS10Gr00 05.05.000
14	5.00	1 x JCP525 / 7.70-D 19.02.202	FKD 5.00 kvar / 14% 04.01.526	KS 12.5 kvar / K3-18ND10230 01.02.025	4	NH / RSUmB / Gr00 / 3p 05.03.002	NHS10Gr00 05.05.000
14	6.25	1 x JCP480 / 7.20-D 19.02.210	FKD 6.25 kvar / 14% 04.01.529	KS 12.5 kvar / K3-18ND10230 01.02.025	4	NH / RSUmB / Gr00 / 3p 05.03.002	NHS16Gr00 05.05.001
14	10.00	1 x JCS525 / 15.0-D 19.02.103	FKD 10.0 kvar / 14% 04.01.528	KS 12.5 kvar / K3-18ND10230 01.02.025	10	NH / RSUmB / Gr00 / 3p 05.03.002	NHS25Gr00 05.05.002
14	12.50	1 x JCS525 / 12.5-D 19.02.180 1 x JCP525 / 5.90-D 19.02.270	FKD 12.5 kvar / 14% 04.01.530	KS 12.5 kvar / K3-18ND10230 01.02.025	10	NH / RSUmB / Gr00 / 3p 05.03.002	NHS25Gr00 05.05.002
14	15.00	1 x JCS525 / 12.5-D 19.02.180 1 x JCP525 / 10.0-D 19.02.150	FKD 15 kvar / 14% 04.01.563	KS 20.0 kvar / K3-24A00230 01.02.026	10	NH / RSUmB / Gr00 / 3p 05.03.002	NHS35Gr00 05.05.003
14	20.00	1 x JCS525 / 12.5-D 19.02.180 1 x JCS525 / 15.0-D 19.02.103"	FKD 20.0 kvar / 14% 04.01.531	KS 25.0 kvar / K3-32A00230 01.02.027	10	NH / RSUmB / Gr00 / 3p 05.03.002	NHS50Gr00 05.05.004
14	25.00	3 x JCS525 / 12.5-D 19.02.180	FKD 25.0 kvar / 14% 04.01.532	KS 50.0 kvar / K3-62A00230 01.02.029	16	NH / RSUmB / Gr00 / 3p 05.03.002	NHS63Gr00 05.05.005
14	30.00	3 x JCS525 / 15.0-D 19.02.103	FKD 30.0 kvar / 14% 04.01.561	KS 50.0 kvar / K3-62A00230 01.02.029	35	NH / RSUmB / Gr00 / 3p 05.03.002	NHS63Gr00 05.05.005
14	40.00	1 x JCS525 / 12.5-D 19.02.180 3 x JCS525 / 15.0-D 19.02.103	FKD 40.0 kvar / 14% 04.01.533	KS 50.0 kvar / K3-62A00230 01.02.029	35	NH / RSUmB / Gr00 / 3p 05.03.002	NHS100Gr00 05.05.007
14	50.00	1 x JCS525 / 12.5-D 19.02.180 4 x JCS525 / 15.0-D 19.02.103	FKD 50.0 kvar / 14% 04.01.534	KS 50.0 kvar / K3-62A00230 01.02.029	50	NH / RSUmB / Gr00 / 3p 05.03.002	NHS125Gr00 05.05.008

# Component selection table for dynamic PFC

Dynamic power factor correction							
De-tuning factor %	Reactive output in kvar	Capacitor Item no.	Filter circuit reactors Item no.	Thyristor actuator Item no.	Cable diameter (mm <sup>2</sup> )	HRC fuse socket Item no.	HRC fuses Item no.
7	2.50	1 x JCP525 / 4.17-D 19.02.275	FKD 2.50 kvar / 7% 04.01.500	TSM-LC10THY 01.02.504	4	NH / RSUmB / Gr00 / 3p 05.03.002	NH00/20A/Ultra Quick 05.05.068
7	5.00	1 x JCP525 / 8.33-D 19.02.249	FKD 5.00 kvar / 7% 04.01.509	TSM-LC10THY 01.02.504	4	NH / RSUmB / Gr00 / 3p 05.03.002	NH00/20A/Ultra Quick 05.05.068
7	6.25	1 x JCS525 / 10.0-D 19.02.150	FKD 6.25 kvar / 7% 04.01.510	TSM-LC10THY 01.02.504	4	NH / RSUmB / Gr00 / 3p 05.03.002	NH00/20A/Ultra Quick 05.05.068
7	10.00	1 x JCP400 / 9.30-D 19.02.219	FKD 10.0 kvar / 7% 04.01.501	TSM-LC10THY 01.02.504	10	NH / RSUmB / Gr00 / 3p 05.03.002	NH00/25A/Ultra Quick 05.05.066
7	12.50	1 x JCP400 / 11.7-D 19.02.221	FKD 12.5 kvar / 7% 04.01.502	TSM-LC10THY 01.02.504	10	NH / RSUmB / Gr00 / 3p 05.03.002	NH00/25A/Ultra Quick 05.05.066
7	15.00	1 x JCP400 / 9.30-D 19.02.221 1 x JCP525 / 8.30-D 19.02.249	FKD 15 kvar / 7% 04.01.512	TSM-LC25THY 01.02.505	10	NH / RSUmB / Gr00 / 3p 05.03.002	NH00/50A/Ultra Quick 05.05.065
7	20.00	2 x JCP400 / 9.30-D 19.02.219	FKD 20.0 kvar / 7% 04.01.503	TSM-LC25THY 01.02.505	10	NH / RSUmB / Gr00 / 3p 05.03.002	NH00/50A/Ultra Quick 05.05.065
7	25.00	2 x JCP400 / 11.7-D 19.02.221	FKD 25.0 kvar / 7% 04.01.504	TSM-LC25THY 01.02.505	16	NH / RSUmB / Gr00 / 3p 05.03.002	NH00/63A/Ultra Quick 05.05.061
7	30.00	3 x JCP400 / 9.30-D 19.02.219	FKD 30.0 kvar / 7% 04.01.505	TSM-LC50THY 01.02.503	35	NH / RSUmB / Gr00 / 3p 05.03.002	NH00/63A/Ultra Quick 05.05.061
7	40.00	3 x JCS440 / 15.0-D 19.02.125	FKD 40.0 kvar / 7% 04.01.506	TSM-LC50THY 01.02.503	35	NH / RSUmB / Gr00 / 3p 05.03.002	NH00/100A/Ultra Quick 05.05.064
7	50.00	4 x JCP400 / 11.7-D 19.02.221	FKD 50.0 kvar / 7% 04.01.507	TSM-LC50THY 01.02.503	50	NH / RSUmB / Gr00 / 3p 05.03.002	NH00/125A/Ultra Quick 05.05.062
14	2.50	1 x JCP525 / 4.17-D 19.02.275	FKD 2.50 kvar / 14% 04.01.525	TSM-LC10THY 01.02.504	4	NH / RSUmB / Gr00 / 3p 05.03.002	NH00/20A/Ultra Quick 05.05.068
14	5.00	1 x JCP525 / 7.70-D 19.02.202	FKD 5.00 kvar / 14% 04.01.526	TSM-LC10THY 01.02.504	4	NH / RSUmB / Gr00 / 3p 05.03.002	NH00/20A/Ultra Quick 05.05.068
14	6.25	1 x JCP480 / 7.20-D 19.02.210	FKD 6.25 kvar / 14% 04.01.529	TSM-LC10THY 01.02.504	4	NH / RSUmB / Gr00 / 3p 05.03.002	NH00/20A/Ultra Quick 05.05.068
14	10.00	1 x JCS525 / 15.0-D 19.02.103	FKD 10.0 kvar / 14% 04.01.528	TSM-LC10THY 01.02.504	10	NH / RSUmB / Gr00 / 3p 05.03.002	NH00/25A/Ultra Quick 05.05.066
14	12.50	1 x JCS525 / 12.5-D 19.02.180 1 x JCP525 / 5.90-D 19.02.270	FKD 12.5 kvar / 14% 04.01.530	TSM-LC10THY 01.02.504	10	NH / RSUmB / Gr00 / 3p 05.03.002	NH00/25A/Ultra Quick 05.05.066
14	15.00	1 x JCS525 / 12.5-D 19.02.180 1 x JCP525 / 10.0-D 19.02.150	FKD 15 kvar / 14% 04.01.563	TSM-LC25THY 01.02.505	10	NH / RSUmB / Gr00 / 3p 05.03.002	NH00/50A/Ultra Quick 05.05.065
14	20.00	1 x JCS525 / 12.5-D 19.02.180 1 x JCS525 / 15.0-D 19.02.103	FKD 20.0 kvar / 14% 04.01.531	TSM-LC25THY 01.02.505	10	NH / RSUmB / Gr00 / 3p 05.03.002	NH00/50A/Ultra Quick 05.05.065
14	25.00	3 x JCS525 / 12.5-D 19.02.180	FKD 25.0 kvar / 14% 04.01.532	TSM-LC25THY 01.02.505	16	NH / RSUmB / Gr00 / 3p 05.03.002	NH00/63A/Ultra Quick 05.05.061
14	30.00	3 x JCS525 / 15.0-D 19.02.103	FKD 30.0 kvar / 14% 04.01.561	TSM-LC50THY 01.02.503	35	NH / RSUmB / Gr00 / 3p 05.03.002	NH00/63A/Ultra Quick 05.05.061
14	40.00	1 x JCS525 / 12.5-D 19.02.180 3 x JCS525 / 15.0-D 19.02.103	FKD 40.0 kvar / 14% 04.01.533	TSM-LC50THY 01.02.503	35	NH / RSUmB / Gr00 / 3p 05.03.002	NH00/100A/Ultra Quick 05.05.064
14	50.00	1 x JCS525 / 12.5-D 19.02.180 4 x JCS525 / 15.0-D 19.02.103	FKD 50.0 kvar / 14% 04.01.534	TSM-LC50THY 01.02.503	50	NH / RSUmB / Gr00 / 3p 05.03.002	NH00/125A/Ultra Quick 05.05.062

## PFC-Accessories

### Dynamic power factor correction

Thyristor control modules		
Item	Weight in kg	Item no.
Control module with Prophi® 6T controller (for 6 capacitor stages) MCCB, CT terminals and 2 m connection cable (mounted on the capacitor module)	3	50.10.003
Control module with Prophi® 12T controller (for 12 capacitor stages) MCCB, CT terminals and 2 m connection cable (mounted on the capacitor module)	3	50.10.004

Fixing rails		
Item	Weight in kg	Item no.
Set fixing rail, left / right (for Rittal cabinets MO84)	1	50.00.100
Set fixing rail, left / right (for Rittal cabinets MO86)	1.5	50.00.101

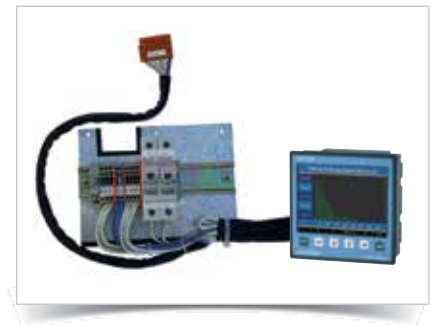
## Accessory – Passive harmonics filter

Control modules	
Item	Item no.
Control module with Prophi® 6R controller, 6 stages (relay outputs) MCCB, CT terminals and 2 m connection cable (mounted on the capacitor module)	50.80.003
Control module with Prophi® 12R controller, 12 stages (relay outputs) MCCB, CT terminals and 2 m connection cable (mounted on the capacitor module)	50.80.004

Fixing rail for slide-in modules in Rittal switch gear cabinets	
Item	Item no.
Set fixing rail, left / right (for Rittal cabinets MO84)	50.00.100
Set fixing rail, left / right (for Rittal cabinets MO86)	50.00.101

Power analyser with Ethernet connection and PQ analysis software		
Item		Item no.
UMG 604E-PRO	DIN rail mounting	52.16.002

See main catalogue chapter 02 "Energy and power quality measurement products" for other variants



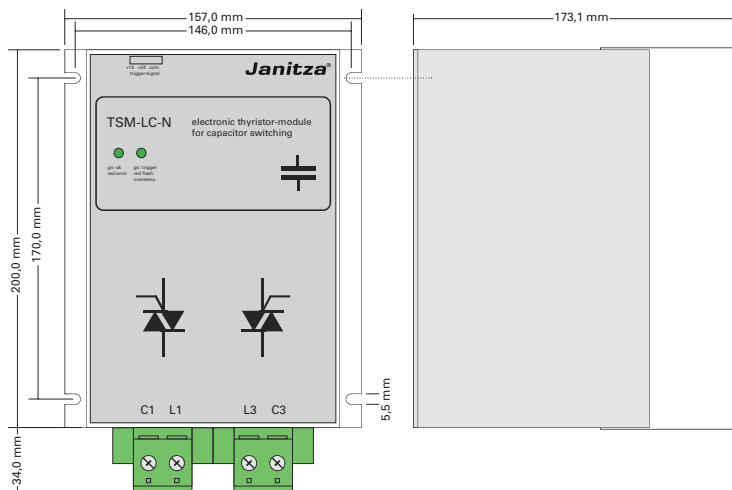
## Electronic circuit breaker (thyristor controller)

### Main features

- Areas of application: dynamic compensation of rapid processes (presses, welding machines, lifts, power plants, wind turbines, etc.)
- Component for developing dynamic compensation systems
- Optimisation of switching behaviour by microprocessor-controlled adaptation to unchoked or choked capacitor branches
- No wearing parts
- Monitoring of voltage, phase, temperature
- Instant switching
- No mains feedback from switching operations (transients)
- No auxiliary voltage required
- Maintenance-free
- Long service life
- No switching noise
- Improved connection technology (connectors)
- Improved temperature management



### Dimension diagrams



### Technical data

Nominal output kvar	Nominal voltage V (50/60 Hz)	Control V DC	Type	Dimensions in mm (W x H x D)	Superfast fuse in A	Weight in kg	Item no.
12,5	400	10 – 24	TSM-LC 10 THY (400 V / 12,5 kvar)	162 x 150 x 75	35	1,75	01.02.504
25	400	10 – 24	TSM-LC-N 25 THY (400 V / bis 25 kvar)	157 x 200 x 173	63	4,80	01.02.516
50	400	10 – 24	TSM-LC-N 50 THY (400 V / bis 50 kvar)	157 x 200 x 173	125	4,80	01.02.515
50 – 85	400 – 690	10 – 24	TSM-LC-N690 THY (690 V / bis 50 kvar)	157 x 200 x 190	125	4,80	01.02.514

## 09 Services

### Services

Page 335

- GridVis® software training
- Commissioning
- Other services
- Checking the power quality and the IT-compliant energy distribution
- Power analysers for leasing
- Analysis and dimensioning of a power factor correction system
- PFC maintenance with performance per maintenance contract
- TeamViewer sessions
- Remote maintenance contracts on an annual basis
- Calibration with calibration reports



## SERVICES



## From planning to commissioning

After we have developed your technical solution, executed it and commissioned it, we continue to support you further:

- Training of your personnel
- Commissioning, maintenance and support of the systems
- Regular training for safe handling of energy management, power quality and our products and system solutions
- On-site power analysis of existing systems

## Training: GridVis® Power Grid Monitoring Software

GridVis® is an elementary module for your energy management and power quality monitoring systems. GridVis® serves to facilitate the programming and configuration of power analysers, universal measurement devices, data loggers and power factor controllers, as well as the configuration, storage, display, processing, analysis and evaluation of the measured data. Our training courses range from training for beginners to individual training courses as well as application and industry-specific conferences. In the GridVis® basic training course you will learn on two consecutive days how to configure your meters with the GridVis® software and how to optimally evaluate and display the acquired information. In order to ensure learning objectives are achieved, each topic is enhanced through independent and practice-oriented exercises. In-house training courses take place in your company and are adapted to suit your individual needs.



### **The goals of the GridVis® basic training are:**

- Become familiar with important functions of the hardware and software
- Be able to create and manage your own projects using the GridVis® software
- Be able to configure Janitza meters correctly
- Be able to display and evaluate measurement and consumption data
- Be able to visualize measurement data using GridVis® Desktop and the web application GridVis® Energy
- Be able to protect your projects using a user management concept
- Be able to automate processes and create your own schedules
- Know how limit values are defined
- Be able to create your own alarm plans



**Further focal points of the GridVis® basic training are:**

- Installation, licensing and update of the GridVis® software
- Detailed examples of many system functions  
(User management, time management, automation and much more)
- Create professional evaluations and reports
- Recording configuration for power quality and residual current monitoring
- Create your own dashboards and widgets
- Generate key performance indicators with evaluation system
- Create virtual measurement points and use them correctly
- Program different UMG meters using Jasic

Training	
Description	Item no.
<b>GridVis® Basic training for beginners</b> , 2 days *1	<b>DL5101135</b>
<b>GridVis® Expert training, main topic: Major projects &amp; Connectivity</b> , 1 day *1 Prerequisite: Basic knowledge of GridVis®.	<b>DL5101136</b>
<b>GridVis® Expert training, main topic: Energy management</b> , 1 day *1 Prerequisite: Basic knowledge of GridVis®.	<b>DL5101137</b>
<b>GridVis® Expert training - Power quality &amp; RCM</b> , 2 days *1 Prerequisite: Basic knowledge of GridVis®.	<b>DL5101138</b>
<b>In-house training at customer site</b> , 1 day *2 Seminar contents after consultation.	<b>DL5101139</b>
<b>GridVis® Webinar training</b> , 1 hour *2 Seminar contents after consultation.	<b>DL5101140</b>

\*1 The participation fee includes training materials, soft drinks, lunch and a certificate. Location: Janitza electronics GmbH / Lahnau  
Travel costs and accommodation must be covered by the seminar participants.

# Commissioning

Janitza possesses decades of know-how in the field of energy measurement technology and complete monitoring systems. We shall be happy to support you from concept generation right through to the commissioning of your monitoring solutions. This encompasses the complete bandwidth of tasks:

- Installation of the GridVis® Power Grid Monitoring Software
- Creation of customer projects in GridVis® with measurement point structure
- Parametrisation of the measurement devices, data loggers and other components in the system according to customer specifications (VBI form for preparation)
- Checking the bus function and accessibility of the measurement devices
- Generation of graph sets
- Generation of topology views
- Brief instruction of the operating personnel on working with the hardware and software components of the Janitza energy management system
- Official system handover



Putting into service	
Description	Item no.
<p><b>Installation of GridVis® up to 10 devices</b>                      Installation of the GridVis® Software on a PC or server including configuration of the system by the manufacturer. Creation of a Janitza database or integration of an existing MySQL or MSSQL database, commissioning, instruction of operating personnel, creation of final protocol with transfer of relevant data in hardware and software, topology configuration and GridVis® device list to the person responsible for the entire installation.                      Travel expenses/overnight stays will be charged additionally at cost.</p>	DL5101090
<p><b>Installation of GridVis® on more than 10 devices</b>                      Installation of the GridVis® on a PC or server including configuration of the system by the manufacturer. Creation of a Janitza database or integration of an existing MySQL or MSSQL database, commissioning, instruction of operating personnel, creation of final protocol with transfer of relevant data in hardware and software, topology configuration and bus address list of the devices to the person responsible for the entire installation.                      Travel expenses/overnight stays will be charged additionally at cost.</p>	DL5101091
<p><b>Installation of GridVis® Desktop on a further computer</b>                      Installation of the GridVis® Desktop on an additional PC, including configuration of the system by the manufacturer, instruction of operating personnel, creation of final protocol.                      Travel expenses/overnight stays will be charged additionally at cost.</p>	DL5101092
<p><b>Acceptance/Checking of cabling</b>                      Commissioning/acceptance of the physical cabling of the system by qualified specialists. Check of Modbus/Ethernet cabling with regard to cable type, polarity, shield earthing, termination, patching of Ethernet connections, compliance with physical topology, etc.                      Creation of communication and electrical data lists in Excel format and transfer to the person responsible for the entire installation.                      Travel expenses/overnight stays will be charged additionally at cost.</p>	DL5101093
<p><b>Commissioning of type 1 measurement device</b>                      Programming of the measurement device parameters by the manufacturer, integration in the GridVis® software for devices UMG 509, 512, 604, 605, 801, 806, RCM202-AB commissioning of the system, instruction of operating personnel, backup of configuration data as a TXT file.                      Travel expenses/overnight stays will be charged additionally at cost.</p>	DL5101094

## Other services

Other services	
Description	Item no.
<p><b>Commissioning of type 2 measurement device</b> Programming of the measurement device parameters by the manufacturer, integration in the GridVis® software for devices UMG 103, UMG 96RM series, UMG 96-PA series, module 800-CT8-A, module EC1, ED1, EI1, commissioning of the system, instruction of operating personnel, backup of configuration data as a TXT file. Travel expenses/overnight stays will be charged additionally at cost.</p>	DL5101095
<p><b>Commissioning of type 3 measurement device</b> Programming of the UMG20CM parameters by the manufacturer, recording of data on site, integration in the GridVis® software, commissioning of the system, instruction of operating personnel, backup of configuration data as a TXT file. Travel expenses/overnight stays will be charged additionally at cost.</p>	DL5101096
<p><b>Commissioning of type 4 measurement device</b> Programming of the ProData 2 parameters by the manufacturer, integration in the GridVis® software, commissioning of the system, instruction of operating personnel, backup of configuration data as a TXT file. Travel expenses/overnight stays will be charged additionally at cost.</p>	DL5101097
<p><b>Commissioning of generic Modbus counter</b> Programming of Modbus measurement devices parameters in accordance with make approved list of Janitza electronics GmbH regarding generic Modbus, implementation in the system, instruction of operating personnel, backup of configuration data as a TXT file. Travel expenses/overnight stays will be charged additionally at cost.</p>	DL5101102
<p><b>Commissioning of pulse media counter</b> Programming of pulse media counter parameters, setting of the pulse values, implementation in the system, instruction of operating personnel. Travel expenses/overnight stays will be charged additionally at cost.</p>	DL5101103
<p><b>Commissioning of MBus Gateway Solvimus</b> Commissioning of the gateway by Janitza, recording of the data on site, integration in the GridVis® software, instruction of operating personnel, creation of final protocol. Travel expenses/overnight stays will be charged additionally at cost.</p>	DL5101104
<p><b>Commissioning of the MBus media counter</b> Programming of the M-Bus media counter parameters for connecting to the MBus Gateway Solvimus, recording of the data on site, setting of the M-Bus parameters, implementation in the system, instruction of operating personnel, creation of final protocol. Travel expenses/overnight stays will be charged additionally at cost. Note: From 25 media counters upwards, an overnight stay is required.</p>	DL5101105
<p><b>Commissioning of the Multi Protocol Server</b> Installation/commissioning of the Multi Protocol Server by Janitza. Commissioning of the system, instruction of operating personnel, creation of final protocol. Travel expenses/overnight stays will be charged at cost.</p>	DL5101106
<p><b>Integration in the Multi Protocol Server</b> Integration of a measurement device in the Multi Protocol Server, recording of the data on site, creation of approx. 5 measured values per measurement device, instruction of operating personnel, creation of final protocol. Travel expenses/overnight stays will be charged additionally at cost.</p>	DL5101107
<p><b>Upgrade of GridVis®</b> Upgrade of the existing and installed GridVis® software to a higher edition, including programming of the system by the manufacturer, commissioning, instruction of operating personnel. Creation of final protocol. Travel expenses/overnight stays will be charged additionally at cost.</p>	DL5101108

## Other services

Other services	
Description	Item no.
<p><b>VISU type 1 service</b> Creation of topology pages in the GridVis®, virtual measuring points (PUE + key figures), cost centre/power quality reports (EN 50160/EN 61000-2-4) upon customer request. Instruction of the operating personnel, creation of final protocol. A specification sheet must be provided by the customer. Travel expenses/overnight stays will be charged additionally at cost.</p>	<b>DL5101109</b>
<p><b>VISU type 2 service</b> Creation of a dashboard page in the GridVis® software with approx. 5 standard widgets, 5 measurement devices and 20 measured values. A specification sheet must be provided by the customer. Travel expenses/overnight stays will be charged additionally at cost.</p>	<b>DL5101110</b>
<p><b>VISU type 3 service</b> Creation of a template page in the GridVis® software with approx. 5 standard widgets and 20 measured values. A specification sheet must be provided by the customer. Travel expenses/overnight stays will be charged additionally at cost.</p>	<b>DL5101111</b>
<p><b>VISU type 4 service</b> Creation of a dashboard overview page in the GridVis® software with links to up to 10 subpages. Travel expenses/overnight stays will be charged additionally at cost.</p>	<b>DL5101112</b>
<p><b>VISU type 5 service</b> Creation of a Sankey diagram or KPI widget with approx. 20 measured values. Creation of a specification sheet in consultation with the client. Travel expenses/overnight stays will be charged additionally at cost.</p>	<b>DL5101113</b>
<p><b>VISU type 6 service</b> Creation of customer-specific graphics for the dashboard pages. A specification sheet must be provided by the customer.</p>	<b>DL5101114</b>
<p><b>Commissioning of type 5 measurement device</b> Programming of the energy counter parameters by the manufacturer, recording of data on site, integration in the GridVis®, commissioning of the system, instruction of operating personnel, creation of final protocol. Travel expenses/overnight stays will be charged additionally at cost.</p>	<b>DL5101123</b>
<p><b>Checking of difference/PE current measurement</b> Checking of difference/PE current measurement by qualified specialists. A live simulation (e.g. test transformer) must be carried out to check the entire alarm/signalling loop of the Janitza system for compliance with the set threshold value as well as when it is exceeded. This must be carried out for each individually monitored inlet/outlet. The results must be logged and given to the specialist engineer in hardware and software form (Excel). Minimum requirement of the log: Project name, distribution list name, outlet designation, measurement device designation, company name, tester name, measured value, signalling chain function, imprinted current magnitude, type of test device, signature and date, price per diff/converter. Travel expenses/overnight stays will be charged at cost.</p>	<b>DL5101125</b>
<p><b>Adaptation of the existing software</b> Adaptation of the existing software to the new constellation of the system including software and device updates, integration of the new devices in the software, optional creation of an additional database connection, instruction of operating personnel, creation of final protocol. Travel expenses/overnight stays will be charged at cost.</p>	<b>DL5101126</b>
<p><b>Instruction</b> Project-based instruction in using the software after commissioning, instruction in the functionality of the entire system. Operation of the software with setting options, analysis representations, visualisation, etc. Travel expenses/overnight stays will be charged at cost.</p>	<b>DL5101127</b>

## Other services

Other services	
Description	Item no.
<p><b>Programming of the compensation system</b> Programming of the compensation network system parameters by the manufacturer, recording of data on site, commissioning, instruction of operating personnel, creation of final protocol with transfer of relevant data in hardware and software, such as bus, ring buffer, measurement devices, topology configuration, to the specialist engineer. Travel expenses/overnight stays will be charged at cost.</p>	DL5101128
<p><b>UMG 20CM Channels</b> Programming of the parameters of the channels, recording of the data on site, setting of the pulse valencies, implementation in the system, instruction of operating personnel, final protocol creation, without travel to and from site.</p>	DL5101130
<p><b>Changing of the system parameters</b> Changing of individual system parameters on site, per bus participant after commissioning by the service technician within the first 12 months after initial commissioning, e.g. - Changing of the recording configuration per device - Changing of the nominal values per device - Changing of the current converter settings per device - Changing of the reports per device in the report - Updating of the firmware per device - Software update if necessary Necessary hardware on loan included if required. Changing of the parameters via the option of VPN or remote access included. Access must be guaranteed and made available by the customer. Alternative: Access per TeamViewer. Travel expenses/overnight stays will be charged additionally at cost.</p>	DL5101133
<p><b>Creation of a virtual device</b> Creation of virtual measuring points (devices) in the GridVis<sup>®</sup> with max. 10 input and output measurements. Travel expenses/overnight stays will be charged additionally at cost.</p>	DL5101134
<p><b>Commissioning and Parametrization JPC100</b> Programming of the JPC100 parameters by the manufacturer, IP configuration, configuration of the alarm system, email configuration, backup of the configuration data Travel expenses/overnight stays will be charged additionally at cost. Note: For the integration of devices, the articles „IBN measurement devices type 1 to type 5“ must also be selected.</p>	DL5101151
<p><b>Commissioning and Parametrization AHF / SVG</b> Programming of the AHF / SVG system parameters by the manufacturer, recording of the data on site, commissioning, instruction of operating personnel, final protocol creation with handover of the relevant data in hardware and software to the specialist engineer. Travel expenses/overnight stays will be charged additionally at cost.</p>	DL5101152
<p><b>Project planning of an energy monitoring or power quality monitoring system</b> Discussion and analysis of the actual status on site, formulation of a customer-specific solution</p>	51.01.011
<p><b>Integration test of generic Modbus devices</b></p>	51.01.014
<p><b>PQ QuickCheck to EN 61000-2-4/EN50160</b> Analysis and evaluation of recorded power quality parameters according to the standards EN 50160 and/or EN 61000-2-4 with recommendation for action in the case of limit value violations or critical parameters. The measured data to be evaluated are read out by the customer in the GridVis<sup>®</sup> software and transferred to the company Janitza via data transfer. Requirement: Installed measurement devices UMG 604-PRO, UMG 605-PRO, UMG 509-PRO, UMG 512-PRO. Each with activated PQ recording and at least data from a coherent calendar week. Alternatively, the measurement can be done by a measuring case on loan.</p>	51.01.024

# Checking the power quality and IT-compliant energy distribution

Energy and system check: Checking the power quality quality and TNS system-compliant electrical installation for IT and other systems.

In order to prevent damage and faults in the systems, a link with fault-free electrical supply systems must be created. If this unit is not established, faults can have a negative effect on operating equipment. Such operating equipment includes in particular sensitive operating equipment such as data transfer systems, PLC controls, as well as supply lines for gas and water (alternating current corrosion).

Occurrences such as faults in the IT system due to EMC problems, damage to systems through hazardous energy peaks, as well as strongly accelerated appearances of corrosion in buildings can lead to severe damage and production failures. Likewise, the personal safety of personnel and that of the system can also be endangered.

## Scope of performance

- Measurement and analysis of the electrical supply system
- Detecting potential error sources and fault factors
- Creation of a detailed report, which provides information on the actual status of the system
- Creation of a measures catalogue for the improvement and optimisation of the energy supply
- Further optional measures such as thermographic investigations, online monitoring including recurrent reporting, system monitoring for monitoring the improved systems, etc. on request

## Benefits

- High operational reliability
- Reduction of production downtimes
- Substantiation of the system state
- Rapid overview of error sources
- Unique error code analysis
- Timely detection of system problems
- Cost centre optimisation of procurement material and repairs
- Extended service life of machines and systems
- Rapid data transfer
- Reports on damaging events
- Improvement of personnel and system protection



Fig.: Avoidance of stray currents on data lines



Fig.: Corrosion of pipes

**Customer-side prerequisites for execution**

- Current transformers and voltage transformers must be available for measurement in the medium voltage power grid
- Presence of the system supervisor or a representative in their absence

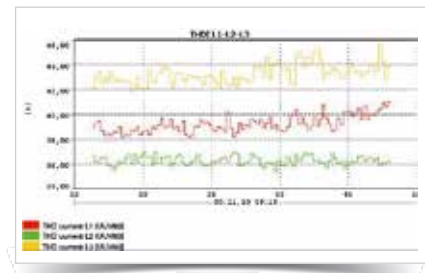


Fig.: Heating up of neutral conductors through high current harmonics

Other services	
Description	Item no.
<p><b>Design of compensation system/network analysis</b>                      Network analysis to assess the network conditions for designing the compensation system with regard to power quality and energy load profiles. The measurement is made in the low voltage network (230/400 V 50 Hz). Recorded and logged in selectable intervals of 5 sec. – 15 min. over a period of 7 days per measuring point.                      The measurement must be carried out during representative operation of the plant section in consultation with the specialist planner. Creation of final protocol with transfer of the relevant data in hardware and software in graphical (pdf/bmp) and numeric (csv/xls) form to the specialist engineer. It is assumed that an electrical specialist with the appropriate specific knowledge of the plant is present during the set-up and dismantling of the measurement.                      Travel expenses/overnight stays will be charged at cost.</p>	<p><b>DL5101129</b></p>

## Power analysers for leasing

### Who is not familiar with the problems of grid distortion effects caused by non-linear loads?

Typical problems such as defective LED lamps, exploded capacitors, short service lives of converters or other electrical loads, flicker occurrences, production failures due to voltage dips, etc. arise frequently in practice. With concrete power quality problems, whereby no fixed installation power analysers are available, we offer mobile power analysers from the MRG (UMG) range for temporary measurement and fault analysis. The network visualisation software GridVis® Essentials is made available in the portable measuring device and in the fixed installation UMG measurement devices. As such, no time-consuming training period is required.



Fig.: MRG portable PQ measuring device

Other services	
Description	Item no.
<p><b>Loan device mobile energy measurement device MRG 96RM-E RCM Flex</b></p> <ul style="list-style-type: none"> <li>• Loan device for one week</li> <li>• For measuring, monitoring and the control of electrical characteristics in power distributions incl. residual current monitoring.</li> <li>• Evaluation with the Power Grid Monitoring Software GridVis®</li> <li>• Incl. Rogowski coil, Item no. 15.03.604 (Ø 95 mm) or 15.03.605 (Ø 190 mm). The size of the Rogowski coil must also be specified in the order.</li> <li>• Current transformer for residual current monitoring on request.</li> </ul>	<b>51.01.030</b>
<p><b>Loan device power quality analyser MRG 512 PQ Flex for a power analysis according to EN 50160</b></p> <ul style="list-style-type: none"> <li>• Loan device for one week</li> <li>• Extensive network data collection with recording of faults</li> <li>• Evaluation of critical network parameters (harmonics, short-time interruptions, ...) and PFC design as well</li> <li>• Evaluation with the Power Grid Monitoring Software GridVis®</li> <li>• Incl. Rogowski coil, Item no. 15.03.604 (Ø 95 mm) or 15.03.605 (Ø 190 mm). The size of the Rogowski coil must also be specified in the order.</li> <li>• Current transformer for residual current monitoring on request.</li> </ul>	<b>51.01.031</b>



## PFC maintenance with performance per the maintenance contract

### Annual reactive power check – function and safety checking of a PFC system

With the aid of a power factor correction system it is possible on the one hand to avoid superfluous reactive power costs by the energy provider, whilst also guaranteeing the optimisation of the energy costs. Furthermore, an improvement in the power quality is also guaranteed with a detuned PFC system because the harmonic currents can be effectively filtered from the network. Checking of the PFC system, which should take place once annually, ensures a long service life and optimum power capability.



### Scope of performance

- Visual inspection of the system, which encompasses the following points: Parts, contactors, fans, connections, capacitors, reactors, lines, checking the housing for damage and deformation
- The regular elimination of dust and pollution prevents creepage distances and short circuits from arising and safeguards the air cooling
- Measurement and recording of the power values for function testing
- Creation of a test report for the actual status of the system
- Further measures: Thermographic testing, etc.

### Benefits

Through consistent care and ensuring the functionality of the system, the following desired beneficial effects and advantages are attained:

- Avoidance of reactive energy costs on a monthly basis, e.g. it is possible to save up to € 500 per month in Germany through the economical configuration of a PFC system with 300 kvar
- Only a carefully maintained system guarantees a long service life; insufficiently cared for systems can also pose a safety risk
- Very short amortisation times of just 1 to 2 years can be guaranteed through a functional PFC system

Other services	
Description	Item no.
Annual PFC check	51.01.025
PFC maintenance with performance per the maintenance contract	51.01.017



## TeamViewer sessions

Our engineers and service technicians possess many years of experience and are frequently able to support you without difficulty by way of a remote session in the event of problems and new systems. Furthermore, remote commissioning and training are also possible via remote maintenance.

Other services	
Description	Item no.
TeamViewer sessions	DL5101050

## Remote maintenance contracts on an annual basis

Safeguard your monitoring and energy management system by having it checked once annually, and keep it in line with the latest engineering practice! Janitza remote maintenance contracts encompasses services including the following:

- Database: Availability, size, available storage
- Availability of the measurement devices (communication to the UMGs)
- Measurement device settings
- Verification of the recorded measured data
- Running test reports
- Under certain circumstances upgrade of the GridVis® Power Grid Monitoring Software
- Under certain circumstances upgrade of the UMG firmware

Other services	
Description	Item no.
Remote maintenance contracts on an annual basis	DL5101060



## Calibration with calibration reports

**Calibration includes the following services:**

- Visual inspection for external damage
- Opening the device and visual inspection for observable damage to electronics and circuit paths
- Comprehensive function check with automatic testing
- Firmware update
- Calibration
- High voltage test (safety check)
- Provision of a factory calibration report

Other services	
Description	Item no.
<p><b>Calibration type 1: UMG 604 / UMG 604-PRO / UMG 605 / UMG 605-PRO / UMG 96RM / UMG 96-PA / UMG 509 / UMG 509-PRO / UMG 512 / UMG512-PRO</b></p> <ul style="list-style-type: none"> <li>– Visual inspection for external damage</li> <li>– Opening of the device and visual inspection for visible damage of conductor tracks</li> <li>– Function control with an automatic inspection</li> <li>– Firmware update</li> <li>– Calibration</li> <li>– High-voltage test (safety review)</li> <li>– Delivery of the manufacturer's calibration protocol</li> </ul>	<b>DL5101143</b>
<p><b>Calibration type 2: UMG 103-CBM / UMG 96-S2</b></p> <ul style="list-style-type: none"> <li>– Visual inspection for external damage</li> <li>– Opening of the device and visual inspection for visible damage of conductor tracks</li> <li>– Function control with an automatic inspection</li> <li>– Firmware update</li> <li>– Calibration</li> <li>– High-voltage test (safety review)</li> <li>– Delivery of the manufacturer's calibration protocol</li> </ul>	<b>DL5101144</b>
<p><b>Calibration type 3: MRG portable energy measurement device</b></p> <ul style="list-style-type: none"> <li>– Visual inspection for external damage</li> <li>– Opening of the device and visual inspection for visible damage of conductor tracks</li> <li>– Function control with an automatic inspection</li> <li>– Firmware update</li> <li>– Calibration</li> <li>– High-voltage test (safety review)</li> <li>– Delivery of the manufacturer's calibration protocol</li> </ul>	<b>DL5101145</b>
<p><b>Firmware update type 1: UMG 604 / UMG 604-PRO / UMG 605 / UMG 605-PRO / UMG 96RM / UMG 96-PA / UMG 509 / UMG 509-PRO / UMG 512 / UMG 512-PRO</b></p> <ul style="list-style-type: none"> <li>– Visual inspection for external damage</li> <li>– Opening of the device and visual inspection for visible damage of conductor tracks</li> <li>– Function control with an automatic inspection</li> <li>– Firmware update</li> <li>– Calibration</li> <li>– High-voltage test (safety review)</li> </ul>	<b>DL5101146</b>
<p><b>Firmware update type 2: UMG 103-CBM / UMG 96-S2</b></p> <ul style="list-style-type: none"> <li>– Visual inspection for external damage</li> <li>– Opening of the device and visual inspection for visible damage of conductor tracks</li> <li>– Function control with an automatic inspection</li> <li>– Firmware update</li> <li>– Calibration</li> <li>– High-voltage test (safety review)</li> </ul>	<b>DL5101147</b>

# 10 Technical annex

- Valid standards
- Energy(data)management – or why ISO 50001 is not everything
- MID – Measuring Instruments Directive
- Overview of the various power quality parameters
- RCM – Residual Current Monitoring
- Constant (gapless) measurement
- Measure, calculate, store - ring buffer was yesterday!
- Collection of mathematical formulas (for UMG measurement devices)
- General information on current transformers
- Overvoltage categories
- Communication via the RS485 interface
- Ports, protocols and connections
- Basis for power factor correction
- Protection classes per EN 60529
- Prerequisite and confirmation for commissioning (VBI)
- 3-in-1-Monitoring



$$I_p = \sqrt{\frac{1}{N} \cdot \sum_{k=0}^{N-1} i_{p_k}^2}$$

## TECHNICAL ANNEX



## Valid standards

Janitza develops, produces and tests its measurement devices and products according to internationally valid standards and directives. The most important national and international standards in conjunction with our products, solutions and applications are as follows:

### General standards and EMC standards:

- **IEC/EN 60868-0:** Assessment of the flicker strength.
- **IEC/EN 61000-2-2:** Electromagnetic compatibility (EMC): Ambient conditions; compatibility level for low frequency, conducted interferences and signal transferral in public low voltage networks.
- **IEC/EN 61000-2-4:** Electromagnetic compatibility (EMC): Ambient conditions; compatibility level for low frequency, conducted interferences in industrial plants.
- **IEC/EN 61000-3-2:** Threshold values for harmonic currents for electrical devices with current consumption of < 16 A per phase.
- **IEC/EN 61000-3-3:** Threshold values – limit of voltage changes, voltage variations and flicker in public low voltage supply networks for devices with a rated current < = 16 A per phase.
- **IEC/EN 61000-3-4:** Electromagnetic compatibility (EMC): Threshold values limit of transmission of harmonic currents in low voltage supply networks for devices and equipment with rated currents of over 16 A.
- **IEC/EN 61000-3-11:** Electromagnetic compatibility (EMC): Threshold values – limit of voltage changes, voltage variations and flicker in public low voltage supply networks; devices and equipment with a rated current < = 75 A.
- **IEC/EN 61000-3-12:** Threshold values for harmonic currents, caused by devices and equipment with a current input of > 16 A and ≤ 75 A per phase, which are intended for connection with public low voltage networks.
- **IEC/EN 61557-12:** Electrical safety in low voltage networks up to AC 1000 V and DC 1500 V – Devices for testing, measuring or monitoring protective measures.

### Power quality standards:

- **EN 50160:** Characteristics of the voltage (PQ) in public electricity supply networks.

- **D-A-CH-CZ:** Technical regulations for the evaluation of grid distortion effects in Germany, Austria, Switzerland and the Czech Republic.
- **TOR D2:** Technical and organisational regulations for operators and users of electrical networks, Part D: Special technical regulations; section D2: Directives for the evaluation of grid distortion effects.
- **IEEE 519:** (Recommended Practices and Requirements for Harmonics Control in Electrical Power Systems) as a common recommendation from energy suppliers and operators for limiting the effects of non-linear loads through the reduction of harmonics.
- **ENGINEERING RECOMMENDATION:** G5/4-1 (planning levels for harmonic voltage distortion to be used in the process for the connection of non-linear equipment) as a directive of the Energy Networks Association (UK) for limiting the effects of non-linear loads through the reduction of harmonics at the transition point (PCC). Valid in Great Britain and Hong Kong.
- **IEEE1159-3 PQDIF:** Recommended Practice for the Transfer of Power Quality Data (data exchange format for power quality data).
- **ITIC (CBEMA):** The ITI curve of the Information Technology Industry Council (ITI) represents the withstand capability of computers / power supplies in relation to the height and duration of voltage variations.

#### **Standards for PQM devices (power quality analysers)**

- **IEC/EN 61000-4-2:** Electromagnetic compatibility (EMC) – Part 4-2: Testing and measurement techniques – Electrostatic discharge immunity test.
- **IEC/EN 61000-4-3:** Electromagnetic compatibility (EMC) Part 4-3: Testing and measurement techniques – Radiated, radio-frequency, electromagnetic field immunity test.
- **IEC/EN 61000-4-4:** Electromagnetic compatibility (EMC) – Part 4-4: Testing and measurement techniques – Electrical fast transient/burst immunity test.
- **IEC/EN 61000-4-5:** Electromagnetic Compatibility (EMC) – Part 4-5: Testing and measurement techniques – Surge immunity test.
- **IEC/EN 61000-4-6:** Electromagnetic compatibility (EMC) Part 4-6: Testing and measurement techniques – Immunity to conducted disturbances, induced by radio-frequency fields.
- **IEC/EN 61000-4-7:** Electromagnetic compatibility (EMC) – Part 4-7: Testing and measurement techniques – General guide on harmonics and interharmonics measurements and instrumentation, for power supply systems and equipment connected thereto.
- **IEC/EN 61000-4-8:** Electromagnetic compatibility (EMC) – Part 4-8: Testing and measurement techniques – Power frequency magnetic field immunity test.

- **IEC/EN 61000-4-11:** Electromagnetic compatibility (EMC) – Part 4-11: Testing and measurement techniques – Voltage dips, short interruptions and voltage variations immunity tests.
- **IEC/EN 61000-4-15:** Electromagnetic compatibility (EMC) – Part 4-15: Testing and measurement techniques – Flickermeter – Functional and design specifications.
- **IEC/EN 61000-4-30:** Electromagnetic compatibility (EMC) – Part 4-30: Testing and measurement techniques – Power quality measurement methods.

#### **Standards for energy measurement devices**

- **DIN EN 62053-21:** Electricity metering equipment (a.c.) – Particular Requirements – Part 21: Static meters for active energy (classes 1 and 2).
- **DIN EN 62053-22:** Electricity metering equipment (a.c.) – Particular requirements – Part 22: Static meters for active energy (classes 0,2 S and 0,5 S).
- **DIN EN 62053-23:** Electricity metering equipment (a.c.) – Particular requirements – Part 23: Static meters for reactive energy (classes 2 and 3).
- **DIN EN 62053-31:** Electricity metering equipment (a.c.) – Particular requirements – Part 31: Pulse output devices for electromechanical and electronic meters (two wires only).
- **DIN EN 60529:** Degrees of protection provided by enclosures (IP code).

#### **Standards for energy management**

- **DIN EN ISO 50001:** Energy management systems – Requirements with instructions on application.
- **DIN EN 16247-1:** Describes the requirements for an energy audit, which enables small and medium-sized companies (SME) to improve their energy efficiency and reduce their energy consumption. Energy audits – Part 1: General requirements; possibility for small and medium-sized companies (SME), in the sense of recommendation 2003/361/EC of the European Commission, to fulfil the requirements of the electricity and energy tax legislation for surplus settlement.



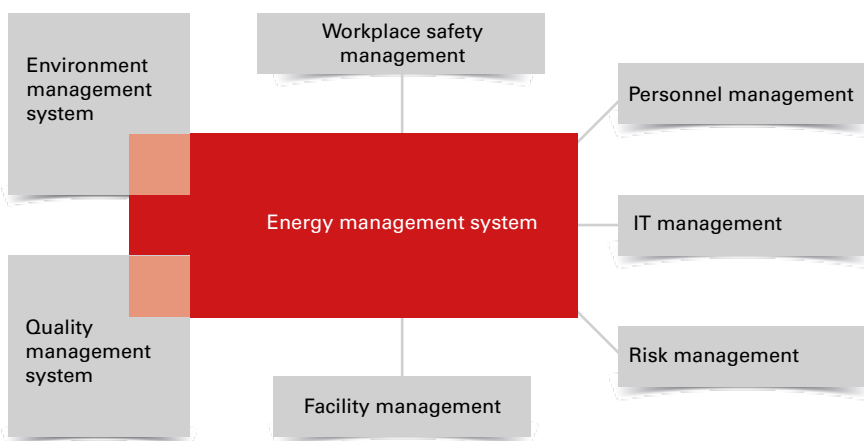
## Energy(data)management – or why ISO 50001 is not everything

We are constantly confronted with the question: "You sell energy management systems?!" The response is always the same: "Yes and no". Our product portfolio encompasses components, software and solutions for the acquisition and analysis of energy-related data and is therefore also the basis for various possible tasks and objectives, and accordingly also for an energy management system.

### ISO 50001

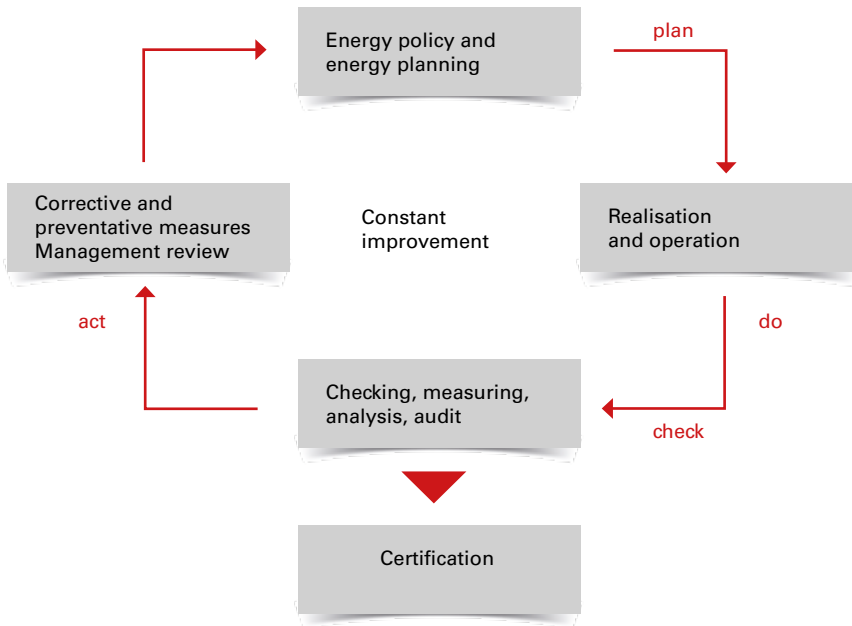
ISO 50001 is the standardised basis for the introduction of an energy management system. The focus here lies on the term management system. This is a methodology, applied in conjunction with other management systems such as ISO 9001 or ISO 14001, through which to set objectives, implement these systematically and in doing so eliminate the chance factor insofar as possible. The term "objective" should essentially be understood here in the sense of "the route is the objective".

Using the PDCA system or Plan-Do-Check-Act a CIP (constant improvement process) is pursued, which assesses the step-by-step processes and procedures for their optimisation potential, as well as stipulating measures and responsibilities and the resources and time frames required for these. ISO 50001 is similar in configuration to ISO 9001 or ISO 14001 and can therefore be easily integrated into existing management systems. This considerably eases the work involved in introduction.



The word "check" in the PDCA process also pertains to the subject of measured data acquisition and evaluation, or expressed otherwise: Energy data management. Without measurement it is not possible to obtain a target/actual comparison or a benchmark. Although no clear specifications are described in ISO 50001 in relation to the scope and frequency of energy measurements,

in practice it is apparent that a minimum volume of measuring technology is required for constant acquisition – at least for all significant loads – otherwise potential can only be determined to a limited degree and saving objectives cannot be adequately attained on a comprehensive basis. Customers who have achieved their certification with a minimum measurement scope recognise – during the ongoing PDCA process – the benefits of comprehensive monitoring across as many loads as possible.



Our measuring systems are scalable in application and grow with the requirements of the customer. Existing structures can be incorporated, and likewise our measuring devices can be integrated in existing systems.

Questions are regularly asked regarding the gauging and subsequent calibration of measuring devices in conjunction with the introduction of ISO 50001. The standard does not specify one or the other. Measuring devices in the form of calibrated meters are not a requirement, nor is the re-calibration of measuring devices at regular intervals. This would mean an infeasible volume of work, because digital measuring devices cannot usually be calibrated whilst installed.

The company requiring certification must merely ensure the comparability of the measurements within the various time frames, and document the checks in the usual way. For our universal measuring devices – if used as intended (ambient temperature!) – this means the accuracy of measurement is always better even after years of use than that of conventional meters immediately after delivery. In practice, we recommend random comparative or parallel measurement of the power and energy values with a high quality measuring device such as our portable measuring devices MRG 605 or MRG 511, via the current transformer measurement terminal strips available from us.

## Who even needs ISO 50001?

(most recent German legal situation 2013)

### EEG § 40 ff. – EEG levy reduction

Under certain conditions companies are entitled to submit an application for a reduction in the EEG (German renewable energy act) levy.

- The company must belong to the manufacturing industry
- The electricity costs must account for at least 14 % of the gross value added
- The annual consumption must be at least 1 GWh per site
- **From an annual consumption of 10 GWh, certification per ISO 50001 is required in order to request the reduction**

The regulation is intended to secure the international competitiveness of energy-intensive companies. Due to the increase in the proportion of renewable energy generators, the EEG levy is likely to continue rising considerably. This means a significant competitive disadvantage for energy-intensive companies. Despite all the half-truths being touted by the media, in practice it is apparent that the lion's share of all companies who have applied for the EEG reduction and received approval for this are actually amongst the most energy-intensive companies and are in international competition. A significantly greater proportion of companies with a high power consumption of > 1 GWh per year fell at the first hurdle of the approval process, with the 14 % gross value added requirement.

### Electricity tax law § 10 – surplus settlement

Under certain conditions, companies in the manufacturing sector are able to benefit from the so-called surplus settlement according to § 10 StromStG. This allows companies to obtain a reimbursement or tax relief against their remaining tax burden, through the application of § 9b StromStG. This "relief in special cases" (surplus settlement) is only granted if the tax burden exceeds € 1,000 in the calendar year (excess/basic amount). The rate of relief is dependent on the difference between the energy tax, which exceeds the basic amount, and the (notional) relief, which is derived on the basis that pension contributions have fallen since the introduction of energy tax (general pension contribution was 20.3 % prior to the introduction of energy tax and now stands at 18.9 %; with an employer contribution of 50 % this means a reduction of 0.7 % for the employer in 2013; the "difference"). A maximum 90 % of this difference is granted as relief, reimbursed or credited. This calculation formula leads to companies with a high power consumption and few employees (subject to statutory pension contributions) profiting in particular from the surplus settlement.

Since 2013 large companies require a certified energy management system per ISO 50001 in order to request the surplus settlement. For small and medium-sized companies (SME) an energy audit per DIN EN 16247-1 is sufficient.

Information on the subject and application can be obtained from the Federal Office of Economics and Export Control: [www.bafa.de/bafa/en/index.html](http://www.bafa.de/bafa/en/index.html)

You can receive applications and information from the main customs office responsible:

[www.zoll.de/EN/Home/home\\_node.html](http://www.zoll.de/EN/Home/home_node.html)

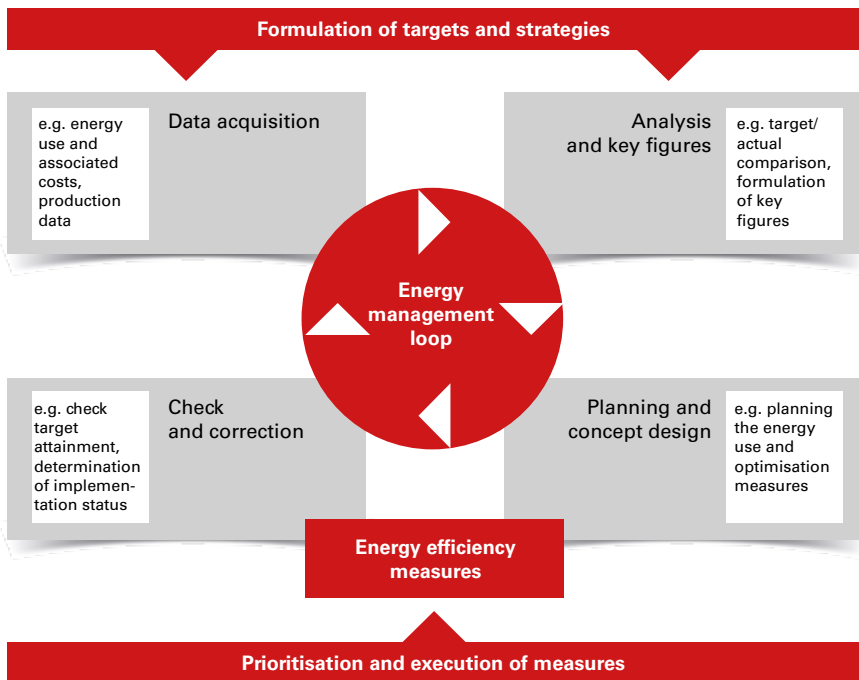
**In practice:**

Managing director F. to works manager A.: "How much current do we actually use?" Works manager A.: "Not entirely sure, certainly a lot!" Managing director F.: "Be sure to change that!" Works manager A. to site electrician M.: "We need to reduce our energy costs. Take care of it." One year later. Managing director F. to works manager A.: "The energy bills are as high as ever. How is that possible?" Works manager A.: "I need to ask M. that." Works manager A. to site electrician M.: "We are still paying crazy energy bills. How is that possible? I told you that you needed to sort that out!" Site electrician M.: "Yes boss. But the controller cancelled the cash for new drives, then my colleague was ill for four weeks and you know that day-to-day work is hectic, the telephone rings constantly and everyone wants something!"

... with ISO 50001 that would not have happened!

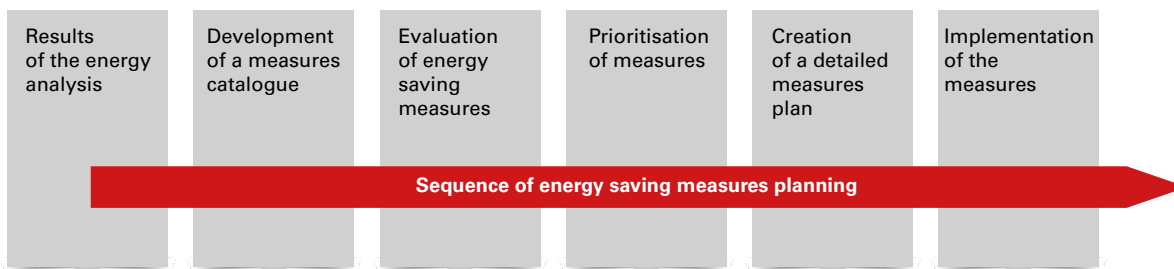
**Who else needs an energy management system (EnMS)?**

Essentially, every company that consumes a certain amount of power and has a large number of different loads and processes benefits from the introduction of an energy management system per ISO 50001. The system behind this ensures sustainable targeted measures for the reduction of energy costs. Furthermore, an EnMS per ISO 50001 will also become an increasingly significant marketing instrument for the presentation of a green and environmentally aware company philosophy in the future.



Energy management constitutes a closed loop with the objective of constant improvement.

One must concede that professionally functioning companies do not necessarily need to establish a certified management system within their organisation, in order to reduce their energy costs on a sustained basis. Furthermore, there are countless companies, for whom the legal prerequisites for an EEG levy reduction or the surplus settlement are irrelevant, whereby ISO 50001 is not a significant subject. However, energy costs remain high. Anyone who establishes the requisite transparency with an energy data management system from Janitza, lays in place the cornerstone for sustainable energy-conscious housekeeping.



### Peak load management and grid fees

A further important aspect for cost reduction, which can be pursued with an energy data management system, is the control and reduction of peak loads. Electricity supply companies calculate grid fees on the basis of the maximum load measured within a quarter of an hour. This value then applies under certain circumstances for the entire year. However, it may be that this value was simply arbitrary or coincidental. It is frequently the case that the actual "troublemakers", responsible for the generation of peak loads, are not immediately discernible.

Only those companies who create transparency regarding the load curves of their significant loads will be able to actively counter these. This can take place through the targeted switching off of loads, through the switching on of their own generators or – where this is not possible for process reasons – with time-delayed switch-on processes or the shutting down of unimportant processes.

According to § 19 section 1 StromNEV (Germany) – special forms of grid use, a further and frequently unknown factor is that supply companies are required to offer their customers a reduced monthly supply tariff if the peak load measured once was significantly higher than normal for the respective company due to unusual circumstances.

### Load management and optimisation of production processes

It is not only peak loads that increase energy costs. Investigations into large production operations have shown that even during shift-free periods and idle phases, depending on the process, annual power consumptions of multiple gigawatt hours can arise per site! A fine-meshed network of measurement points within the production structures in conjunction with modern PLC controllers and production control systems enable automated optimisation in real-time at high level. Janitza monitoring devices and systems are suitable for

You can find a helpful overview of all subjects pertaining to ISO 50001, energy efficiency and subsidy options for the German market on the following internet sites:

Federal Office of Economics and Export Control: [http://www.bafa.de/EN/Home/home\\_node.html](http://www.bafa.de/EN/Home/home_node.html)

From the main customs offices: [www.zoll.de/EN/Home/home\\_node.html](http://www.zoll.de/EN/Home/home_node.html)

DENA – German energy agency: [www.dena.de/en.html](http://www.dena.de/en.html)

The DENA list of certified energy consultants: [www.energie-effizienz-experten.de](http://www.energie-effizienz-experten.de)

Credit institute for reconstruction [www.kfw.de/kfw.de-2.html](http://www.kfw.de/kfw.de-2.html)

A comprehensive overview of all subsidy measures: [www.foerderdatenbank.de](http://www.foerderdatenbank.de)

Federal Ministry for the Environment, Nature Conservation and Nuclear Safety: [www.bmu.de/energieeffizienz](http://www.bmu.de/energieeffizienz)

NRW energy agency: [www.energie-im-unternehmen.de](http://www.energie-im-unternehmen.de)  
IHK, TÜV and DEKRA on their state-specific websites

this task due to their open communication interfaces, the high sampling rate and accuracy of measurement.

**Load management and purchasing electricity**

Anyone who knows their load curves and buys electricity on the spot market is naturally able to do so with pinpoint accuracy, with precise knowledge of their volatile demand due to their load profiles.

**Grants and public funds**

The state provides comprehensive assistance for the implementation of measures and investment in systems and operating equipment for the enhancement of energy efficiency. From low-interest credit to actual investment grants and covering the costs of (sometimes mandatory) certified energy consultants. The list is long and the offers change all the time and vary from country to country.

# MID – Measuring Instruments Directive

The abbreviation MID stands for the term "**Measuring Instruments Directive**" and is the equivalent of the German term "**Messgeräte-Richtlinie**". This refers to the measuring instruments directive 2004/22/EC of the European parliament and the council dated the 31st March 2004.

## What are the aims of the MID?

- EU-wide regulation of the market access of respective measuring devices
  - Creation of a harmonised European market for measuring devices
  - Uniform approval process for all EU states and individual additional states
  - Single, uniform approval testing
  - Uniform, cross-border specification for first calibration
- Uniform product labelling
- Reduction of tests and test costs
  - First calibration takes place through a manufacturer's declaration of conformity
  - Separate calibration testing and calibration fees omitted
  - Reduced delivery times
- Equality in competition due to high requirements for product quality
  - Additional requirements regarding precision in the small load range
  - Higher EMC requirements
  - Improved picture of the latest measuring technology status

## What does MID regulate?

The MID applies to 10 types of measuring device (electricity meters, water meters, gas meters, etc.) in the fields of statutory metrology, and defines fundamental and measuring device-specific requirements.

A conformity evaluation process – whereby the cooperation of a notified body chosen by the manufacturer is prescribed – replaces the previous first calibration by the calibration authority or the state-certified test centre.

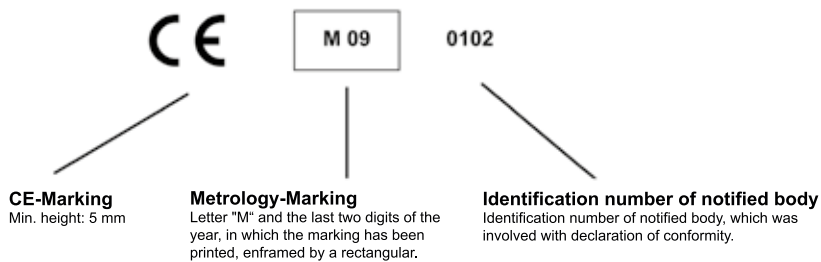
It transfers the responsibility for first circulation and first commissioning within the EU to the manufacturer. After this, national law applies.

The manufacturer must select one of the conformity evaluation processes prescribed in the MID, through which they guarantee the compliance of the measuring device with the MID under the supervision of a notified body. Only then is it permissible to put the measuring device - compliant with the MID - into circulation or into operation. A declaration of conformity must be supplied with the meter. This is frequently printed in the operating manual.

Following circulation or commissioning of the measuring device, the responsibility for attaining accurate measuring results passes to the user.

**Labelling the devices**

The sequence of MID labelling is prescribed and must comply with the following example:



**Re-calibrating?**

The MID has no effect on re-calibrating according to calibration regulations. Measuring devices, whose conformity has been specified in a prescribed conformity evaluation process and which are correctly labelled, are deemed in Germany to have been initially calibrated.

The measuring device user is once again responsible for submitting a timely application for re-calibration.

The duration of calibration validity is stipulated in the national calibration ordinance. In Germany, this is a period of eight years after MID labelling in the case of electronic electricity meters.

Further information applicable to Germany can be found under the following link: [www.eichamt.de](http://www.eichamt.de)



## Overview of the various power quality parameters

In modern energy supply a wide range of single and three-phase, non-linear loads are used in industrial networks right through to office blocks. These include lighting equipment such as lighting controls for headlamps or low energy bulbs, numerous frequency converters for heating, air conditioning and ventilation systems, frequency converters for automation technology or lifts, as well as the entire IT infrastructure with the typically used regulated switched mode power supplies. Today, one also commonly finds inverters for photovoltaic systems (PV) and uninterruptible power supplies (UPS). All of these non-linear electrical loads cause grid distortion effects to a greater or lesser extent, with a distortion of the original "clean" sinusoidal form. This results in the current or voltage waveform being distorted in the same way.

The reliable operation of modern plants and systems always demands a high degree of supply reliability and good power quality.

The load on the network infrastructure through electrical and electronic loads with grid distortion effects has increased significantly in recent years. Depending on the type of generation system and the operating equipment (mains feed with converter, generator), mains rigidity at the connection point and the relative size of the non-linear loads, varying strengths of grid distortion effects and influences arise.

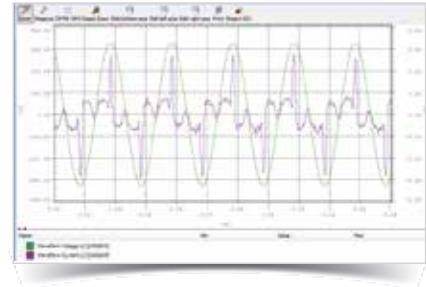


Fig.: Distorted current form through consumer electronics

**The following power quality parameters must be taken into particular consideration:**

- Harmonics
- Current and voltage unbalance
- Rapid voltage changes - transients
- Voltage dips and short-term overvoltage
- Voltage interruption (SIs - short term interruptions)
- Flicker
- Phase shifting and reactive power

# Harmonics

The constantly rising number of non-linear loads in our power networks is causing increasing "noise on the grid". One also speaks of grid distortion effects, similar to those that arise in the environment due to water and air pollution. Generators ideally produce purely sinusoidal form current at the output terminals. This sinusoidal current form is considered the ideal alternating current form and any deviation from this is designated mains interference.

An increasing number of loads are extracting non-sinusoidal current from the grid. The FFT-Fast-Fourier-Transformation of this "noisy" current form results in a broad spectrum of harmonic frequencies - often also referred to as harmonics.

Harmonics are damaging to electrical networks, sometimes even dangerous, and connected loads are harmed by these; in a similar way to the unhealthy effect that polluted water has on the human body. This results in overloads, reduced service lives and in some cases even the early failure of electrical and electronic loads.

Harmonic loads are the main cause of invisible power quality problems and result in massive maintenance and investment costs for the replacement of defective devices. Grid distortion effects of an impermissible high level and the resultant poor power quality can therefore lead to problems in production processes and even to production downtimes.

Harmonics are currents or voltages whose frequency lies above the 50/60-Hz mains frequency, and which are many times this mains frequency. Current harmonics have no portion of the effective power, they only cause a thermal load on the network. Because harmonic currents flow in addition to "active" sinusoidal oscillations, they cause electrical losses within the electrical installation. This can lead to thermal overloads. Additionally, losses in the load lead to heating up or overheating, and therefore to a reduction in the service life.

The assessment of harmonic loads usually takes place at the connection or transition point to the public mains supply network of the respective energy supplier. One speaks in this case of a Point of Common Coupling (PCC). Under certain circumstances it may also be important to determine and analyse the harmonic load through individual operating equipment or equipment

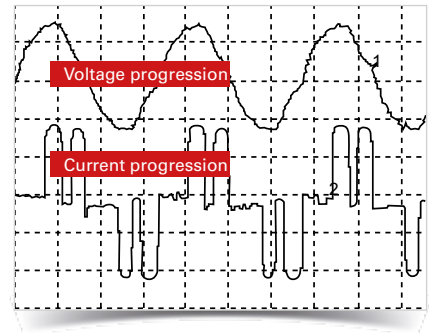


Fig.: Grid distortion effects through frequency converters

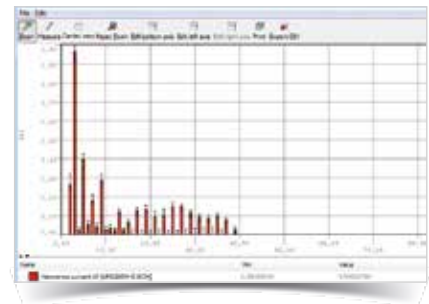


Fig.: Harmonics analysis (FFT)

Threshold values of individual harmonic voltages at the transition point up to the 25th order as a percentage of the fundamental oscillation U1					
Odd harmonics				Even harmonics	
No multiple of 3		Multiple of 3			
Order h	Relative voltage amplitude U <sub>h</sub>	Order h	Relative voltage amplitude U <sub>h</sub>	Order h	Relative voltage amplitude U <sub>h</sub>
5	6.0 %	3	5.0 %	2	2.0 %
7	5.0 %	9	1.5 %	4	1.0 %
11	3.5 %	15	0.5 %	6 to 24	0.5 %
13	3.0 %	21	0.5 %		
17	2.0 %				
19	1.5 %				
23	1.5 %				
25	1.5 %				

groups, in order to indicate internal power quality problems and possibly determine their causes.

The following parameters are used to assess harmonic loads:

### Total Harmonic Distortion (THD)

Total Harmonic Distortion (THD) is a means of quantifying the proportion of distortion arising due to the non-linear distortion of an electrical signal. It therefore gives the ratio of the effective value of all harmonics to the effective value of the mains frequency. The THD value is used in low, medium and high voltage systems. Conventionally,  $THD_i$  is used for the distortion of current, and  $THD_u$  for the distortion of voltage.

#### THD for voltage

- M = Ordinal number of harmonics
- M = 50 (UMG 605-PRO, UMG 512-PRO)
- Mains frequency fund equals  $n = 1$

#### THD for current

- M = Ordinal number of harmonics
- M = 50 (UMG 605-PRO, UMG 512-PRO)
- Mains frequency fund equals  $n = 1$

### Total Demand Distortion (TDD)

In North America in particular, the expression TDD is commonly used in conjunction with the issue of harmonics. It is a figure that refers to  $THD_i$ , although in this case the total harmonic distortion is related to the fundamental oscillation portion of the nominal current value. The TDD therefore gives the relationship between the current harmonics (analogous to the  $THD_i$ ) and the effective current value under **full load conditions** that arises within a certain interval. Standard intervals are 15 or 30 minutes.

#### TDD (I)

- TDD gives the relationship between the current harmonics ( $THD_i$ ) and the effective current value with a full load.
- $I_L$  = Full load current
- M = 50 (UMG 605-PRO, UMG 512-PRO)

Voltage drops can lead to huge complications – for example the failure of production processes – and to quality problems. Such voltage drops arise much more frequently than interruptions. The commercial effects of voltage



Fig.: Capacitors destroyed due to harmonics

$$THD_u = \frac{1}{|U_{fund}|} \sqrt{\sum_{n=2}^M |U_{n.Harm}|^2}$$

$$THD_i = \frac{1}{|I_{fund}|} \sqrt{\sum_{n=2}^M |I_{n.Harm}|^2}$$

$$TDD = \frac{1}{I_L} \sqrt{\sum_{n=2}^M I_n^2} \times 100\%$$

## Current / voltage unbalance

One speaks of balance in a three-phase system if the three phase voltages and currents are of an equal size and are phase-shifted at  $120^\circ$  to each other.

Unbalance arises if one or both conditions are not fulfilled. In the majority of cases the cause of unbalance lies in the loads.

In high and medium voltage power grids the loads are usually three-phase and symmetrical, although large one- or two-phase loads may also be present here (e.g. mains frequency induction furnaces, resistance furnaces, etc.). In the low voltage network electrical loads are frequently also single-phase (e.g. PCs, consumer electronics, lighting systems, etc.), and the associated load current circuits should be distributed as evenly as possible within the electrical wiring on the three phase conductors. Depending on the symmetry of the single-phase loads, the network is operated on a more balanced or unbalanced basis.

The compatibility level for the degree of unbalance of the voltage in stationary operation caused by all mains loads is defined as  $\leq 2\%$ . Related to individual load systems the resultant degree of unbalance is limited to  $= 0.7\%$ , whereby an average over 10 minutes must be obtained.

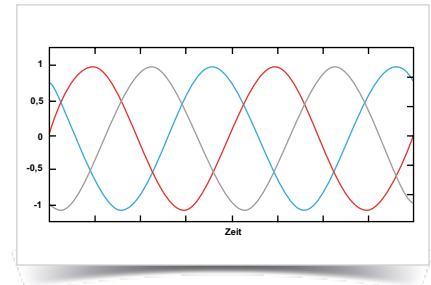


Fig.: Balance

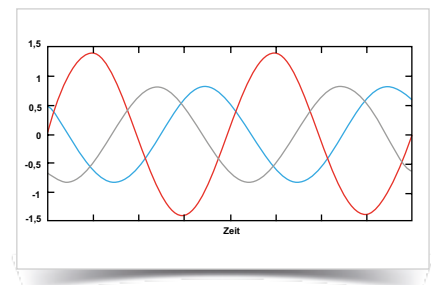


Fig.: Unbalance

### The following effects arise due to unbalance in the voltage:

- Increased current loading and losses in the network.
- With equal load power the phase currents can attain 2 to 3 times the value, the losses 2 to 6 times the value. It is then only possible to load lines and transformers with half or one third of their rated power.
- Increased losses and vibration moments in electrical machinery.
- The field built up by the negative sequence component of the currents runs against the phase sequence of the rotor and therefore induces currents in it, which lead to increased thermal loading.
- Rectifiers and inverters react to unbalance in the power supply with uncharacteristic harmonic currents.
- In three-phase systems with star connection, current flows through the neutral conductor.

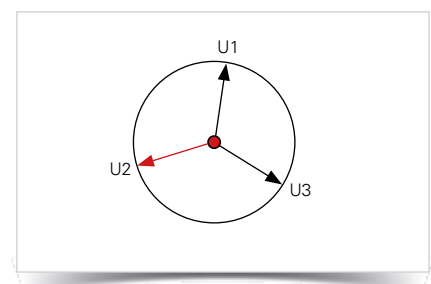


Fig.: Illustration of unbalance in the Vector diagram

You can find the related detailed formulas in the collection of formulas.

## Transients

Transients are pulsed electrical phenomena, which exist for just a short period of time. These are usually high frequency, steep signals in the form of transient oscillations.

The reliable detection of transient processes in the electrical supply network is very important in order to avoid damages. Through constant changes in the electrical supply network due to switching operations and faults, new network states arise constantly, which the entire system is required to tune itself to. In normal cases transient compensation currents and compensation voltages arise here. In order to assess whether the transient processes result from a desired or undesired change in the network, and whether these still lie in the tolerance range, one requires reliable decision criteria.

High transient overvoltage, and high  $dV/dt$ -ratios, can lead to insulation damage and the destruction of systems and machines, also depending on the energy input (e.g. lightning strike).

In order to detect and record transients it is necessary to use high quality, digital power quality analysers with a high sampling rate.

### Practical example:

High transient currents often arise due to the switching – in of capacitors (without reactors or damping facility) – also with problem-free network configurations. Choking has a strongly damping effect and therefore protects against avoidable problems that are difficult to foresee. Alternatively, special capacitor contactors or switching devices should be used, e.g. with pre-charging resistors at LV side.

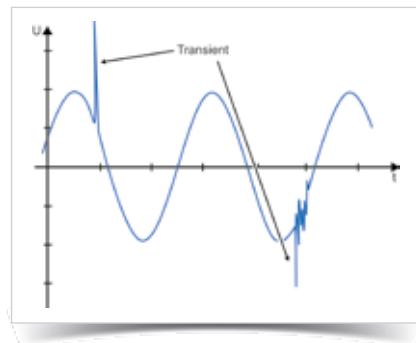


Fig.: Transients

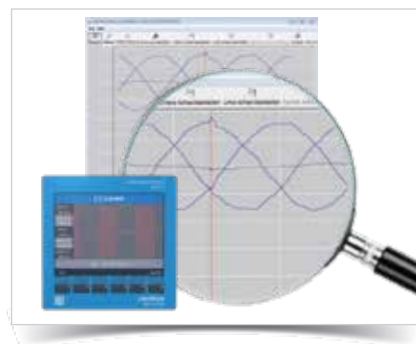


Fig.: With the UMG 512-PRO it is possible to display the transients directly on the measuring device.



# Voltage dips and interruptions

drops are seriously underestimated time and again.

## What is a voltage drop?

According to the European standard EN 50160 a voltage drop is a sudden lowering of the effective voltage value to a value of between 90% and 5% of the stipulated nominal value, followed by the immediate reinstatement of this voltage. The duration of a voltage drop lies between a half period (10 ms) and one minute.

If the effective value of the voltage does not drop below 90% of the stipulated value then this is considered to be normal operating conditions. If the voltage drops below 5% of the stipulated value then this is considered an interruption.

A voltage drop should therefore not be confused with an interruption. An interruption arises, for example, after a circuit breaker has tripped (typ. 300 ms). The mains power failure is propagated throughout the remaining distribution network as a voltage drop.

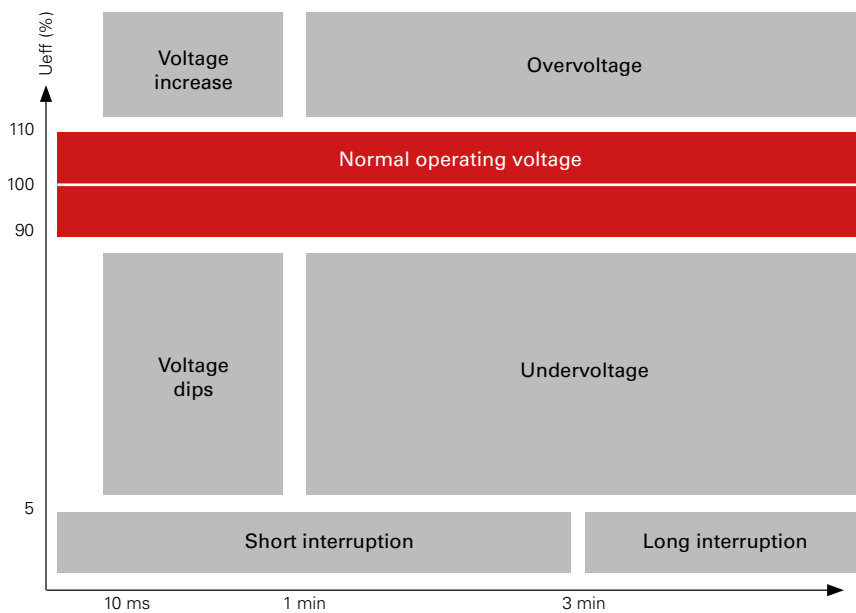
The diagram clarifies the difference between a drop, a short interruption and an undervoltage situation.

## Voltage variations are caused by:

- Short circuits



Fig.: Example: Voltage dips due to bird droppings



- Switch-on and switch-off processes with large loads
- Starting drives (larger load)
- Load changes with drives
- Pulsed power (oscillation package controls, thermostatic controls)
- Arc furnaces
- Welding machines
- Switching on capacitors
- Construction works
- Bird droppings

Voltage drops can lead to the failure of computer systems, PLC systems, relays and frequency converters. With critical processes just a single voltage dip can result in high costs, continuous processes are particularly impacted by this. Examples of this are injection moulding processes, extrusion processes, printing processes or the processing of foodstuffs such as milk, beer or beverages.

**The costs of a voltage drop are comprised of:**

- Loss of profits due to production stoppage
- Costs for catching up with lost production
- Costs for delayed delivery of products
- Costs for raw materials wastage
- Costs for damage to machinery, equipment and moulds
- Maintenance and personnel costs

Sometimes processes run in unmanned areas in which voltage drops are not immediately noticed. In this case an injection moulding machine, for example, could come to a complete standstill unnoticed. If this is discovered later there will already be a large amount of damage. The customer receives the products too late and the plastic in the machine has hardened off.

## Flicker

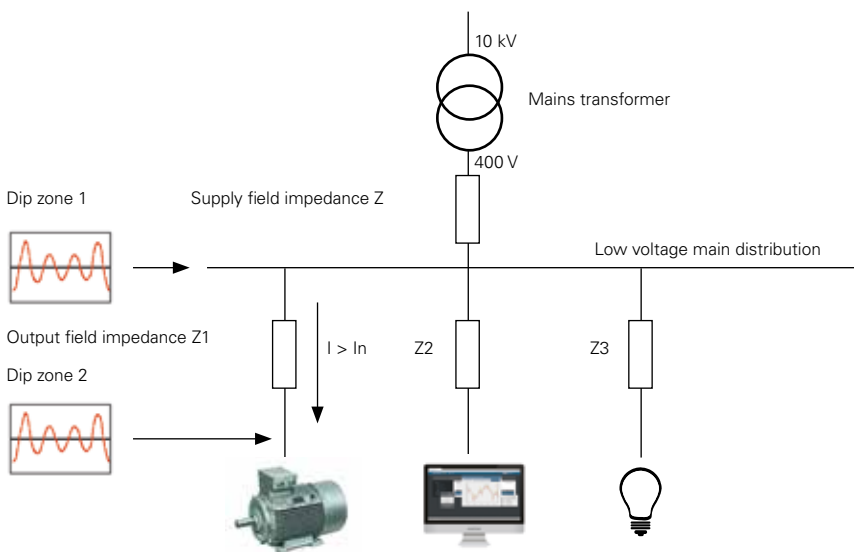


Fig.: Motor start-up currents can lead to a voltage dip

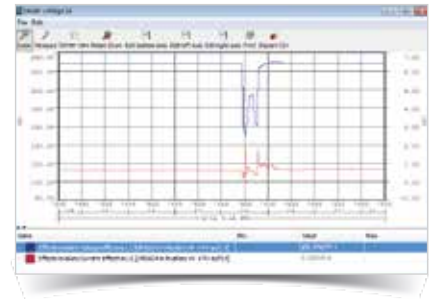


Fig.: Critical voltage dip with production standstill

Flicker refers to the subjective impression of light density changes or an impression of unsteadiness of visual perceptions, caused by luminous stimuli with temporal fluctuations of the light density or the spectral distribution. From a technical perspective, voltage variations cause light density changes in lamps, which can result in visual perceptions referred to as flicker. From a certain threshold value the appearance of flicker can be disturbing. The disturbing effect of voltage variations depends here on the extent of the repetition rate and the curve form of the change in voltage. The short-term flicker strength and long-term flicker strength are defined measures of the disturbing effect.

Voltage variations, caused by individual devices (on the low voltage network), are permissible if the resultant flicker disturbance factor is not greater than 1. The long-term flicker disturbance factor averaged from twelve values must not exceed a value of 0.65. The most simple method for evaluating the value is the  $= 1$  p.u. curve. P.u. stands here for the "unit of perception" and is the maximum tolerance level for the interference sensitivity of the human eye with regards to its perception of light fluctuations. It is also not permissible to exceed the value  $= 1$  p.u. in combination with all interferers.

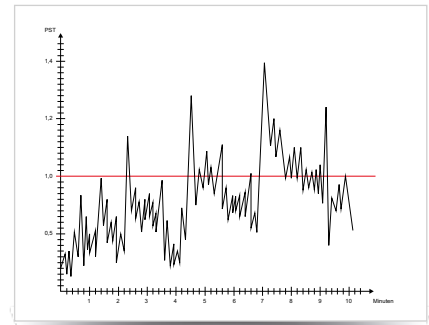


Fig.: Development over time of short-term flicker (PST)



Fig.: Practical example for flicker: Gravel quarry

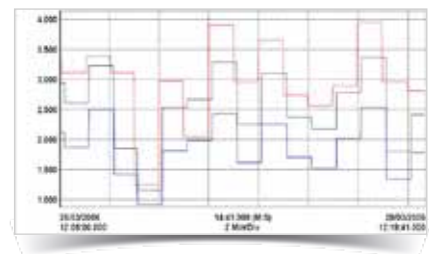


Fig.: Development of flicker

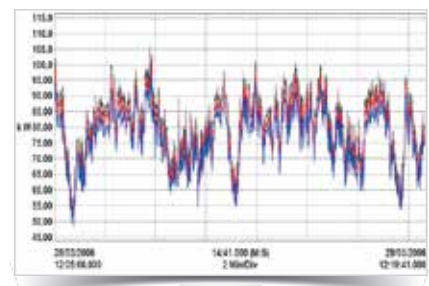


Fig.: Effective power development dependent on the volume and consistency of material



## Phase shifting and reactive power

Reactive power is required in order to generate electromagnetic fields in machines such as three phase motors, transformers, welding systems, etc. Because these fields build up and break down continuously, the reactive power swings between generator and load. In contrast to the effective power it cannot be used, i.e. converted into another form of energy, and burdens the supply network and the generator systems (generators and transformers). Furthermore, all energy distribution systems for the provision of the reactive current must exhibit larger dimensions.

It is therefore expedient to reduce the inductive reactive power arising close to the load through a counteractive capacitive reactive power, of the same size where possible. This process is referred to as power factor correction. With power factor correction, the proportion of inductive reactive power in the network reduces by the reactive power of the power capacitor of the power factor correction system (PFC). The generator systems and energy distribution equipment are thereby relieved of the reactive current. The phase shifting between current and voltage is reduced or, in an ideal situation with a power factor of 1, entirely eliminated.

The power factor is a parameter that can be influenced by mains interference such as distortion or unbalance. It deteriorates with progressive phase shifting between current and voltage and with increasing distortion of the current curve. It is defined as a quotient of the sum of the effective power and apparent power, and is therefore a measure of the efficiency with which a load utilises the electrical energy. A higher power factor therefore constitutes better use of the electrical energy and ultimately also a higher degree of efficiency.

### Power Factor (arithmetic)

- The power factor is unsigned

### cos phi – Fundamental Power Factor

- Only the fundamental oscillation is used in order to calculate the cos phi
- cos phi sign ( $\varphi$ ):
  - = for delivery of effective power
  - + = for consumption of active power

Because no uniform phase shifting angle can be cited with harmonic loading, the power factor  $\lambda$  and the frequently used effective factor  $\cos(\varphi_1)$  must not be equated with each other. Starting with the formula  $\lambda = \frac{P_1}{S} = \frac{1}{g_1} \cos(\varphi_1) = g_1 \cos(\varphi_1)$  with  $I_1$  = fundamental oscillation effective value of the current,  $I$  = total effective value of the current,  $g_1$  = fundamental oscillation content of the current and  $\cos(\varphi_1)$  = shifting factor, one sees that only with sinusoidal form voltage and current ( $g = 1$ ) is the power factor  $\lambda$  the same as the shifting factor  $\cos(\varphi_1)$ . As such, exclusively with sinusoidal form currents and voltages is the power factor  $\lambda$  the same as the cosine of the phase shifting angle  $\varphi$  and is defined as  $\cos(\varphi) = \frac{P}{S} =$  effective factor.

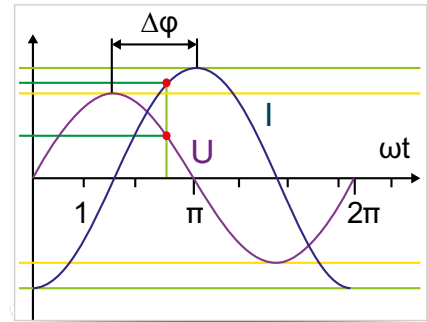


Fig.: Phase shifting between current and voltage ( $\Delta\varphi$ )

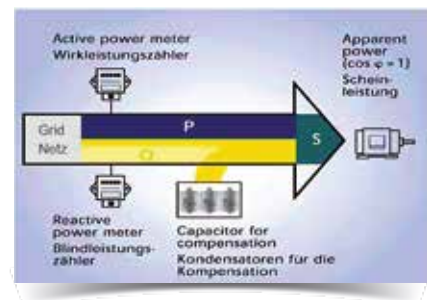


Fig.: Principle of power factor correction

$$PF_A = \frac{|P|}{S_A}$$

Fig.: Power Factor (arithmetic)

$$PF_1 = \cos(\varphi) = \frac{P_1}{S_1}$$

Fig.: cos phi – Fundamental Power Factor

# RCM – Residual Current Monitoring

## General information

Residual currents caused by the failure of insulation can constitute a significant risk to safety in electrical systems. Using an appropriate protective concept it is possible to detect residual currents, eliminate insulation faults in good time and therefore ensure the availability of the system.

RCM stands for **Residual Current Monitoring** and means the monitoring of residual currents in electrical systems. This current is calculated as the sum of the currents of all conductors, apart from the protective earth (PE), which feed into the system. Residual currents are typically the result of insulation faults, leakage currents or EMC filter leakage currents for example.

Whilst RCD devices (residual current circuit breakers) switch off the power supply in the event of a certain residual current being exceeded, RCM measuring devices indicate the actual value, record the long-term development and report the exceeding of a critical value. This message can also be used in order to switch off the power supply via external switching devices (contactors, relays). Through the use of residual current measuring devices (Residual Current Monitoring, RCM) it is possible to detect and report residual currents in a timely manner. It is possible to initiate counter measures in good time, so that it is not necessary to switch the system off. This facilitates the implementation of measures in the event of slowly deteriorating insulation values or steadily rising residual currents – caused for example by ageing insulation – before the system is switched off. For example:

- Insulation faults of lines and electrical operating resources
- Residual currents from electrical loads
- Defective PP power capacitors for the PFC
- Defective components in switched mode power supplies, e.g. in computers
- Correctness of TNS systems (Terra Neutral Separate)
- Disclosure of impermissible PEN connections
- Avoidance of neutral conductor reverse currents to grounded equipment

Residual current monitoring in conjunction with energy measurement in combined energy / RCM measuring devices in electrical systems constitutes a measure for fire protection and maintenance prevention. Down times and the associated costs are thereby reduced. Timely and preventative maintenance – facilitated through the information additionally gained from an RCM measuring device – also significantly enhances the efficiency and availability of a system.

Constant RCM monitoring is of particular significance in preventing unwanted surprises in ongoing operation, and provides consistent information regarding the actual status of the electrical system.

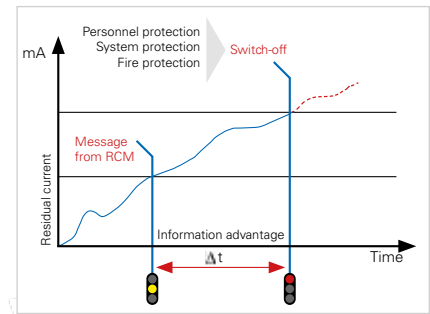


Fig.: Report prior to switching off - an aim of residual current monitoring

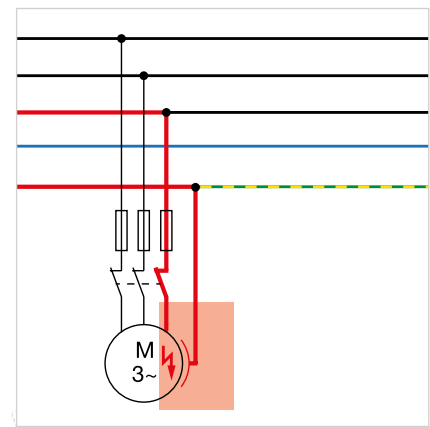


Fig.: Fault current to ground through high ohmic ground fault

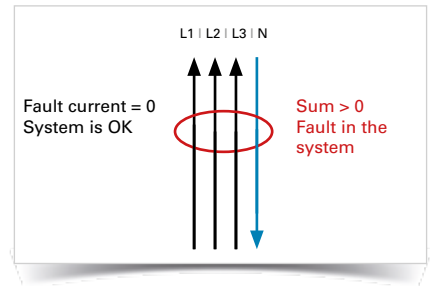
### Fundamental measuring process with RCM

The functionality of RCM measuring devices is based on the differential current principle. This requires that all phases be guided through a residual current transformer at the measuring point (outlet to be protected), with the exception of the protective earth. If there is no failure in the system then the sum of all currents will be nil. If, however, residual current is flowing away to ground then the difference will result in the current at the residual current transformer being evaluated by the electronics in the RCM measuring device.

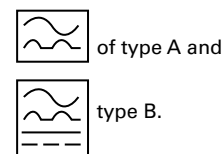
The measurement process is described in IEC/TR 60755. Differentiation is made here between type A and type B.

### DIN EN 62020 / VDE 0663 / IEC 62020 standard:

The standard applies to residual current monitoring devices for domestic installations and similar applications with a rated voltage of < 440 V AC and a rated current of < 125 A.



The UMG 96RM-E can measure residual currents in accordance with IEC/TR 60755 (2008-01)



### Optimum monitoring through 6 current measurement channels

Modern, highly integrated measuring devices facilitate the combined measurement of

- Electrical parameters (V, A, Hz, kW ...)
- Power quality parameters (harmonics, THD, SIs ...)
- Energy loads (kWh, kvarh ...)
- RCM residual current in just one measuring device. The following example shows a measuring device with 6 current inputs for this purpose:

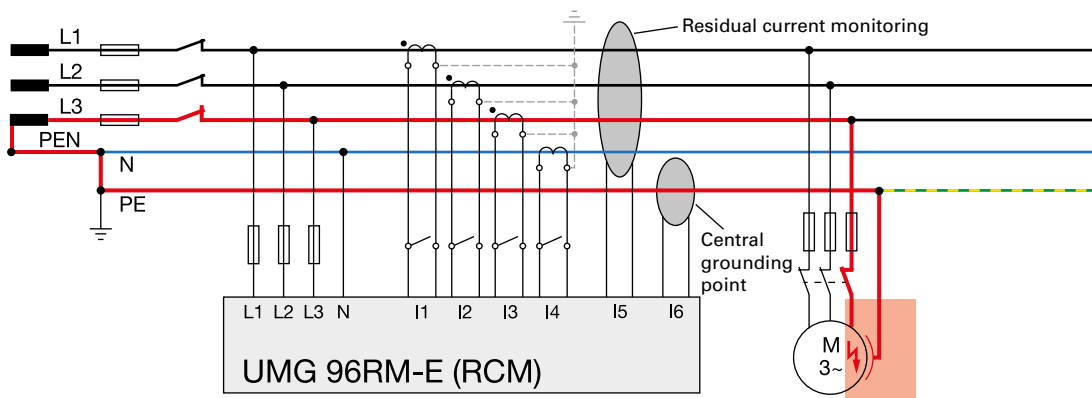


Fig.: Fault current to ground due to an insulation ageing of the motor windings. Minor current through high ohmic fault can be captured with RCM in time and remedial measures initiated to avoid a solid short circuit over time. Thus a production stop can be avoided, as well the risk of a possible fire damage in a worst case scenario.

# Constant measurement

## In the past

In the past, the micro-processors available on the market were not sufficiently powerful for measuring and simultaneously calculating the various parameters.

"Every measuring device measures constantly, doesn't it..."

Customer quote

It was therefore only feasible to carry out random measurements with older measuring devices. In other words measurements were taken for a number of cycles, measuring was subsequently stopped and the values were calculated. No further measurements were taken during processing. This meant that measurements were only taken for a few periods out of 50 periods.

## In the present

With the new product families, such as the UMG 96RM, UMG 604-PRO, UMG 605-PRO, UMG 509-PRO, UMG 512-PRO, leading-edge microprocessors are used with an entirely new architecture, integrated performance scope and considerably higher capacities.

Such processors were not available in the past! These processors are more expensive than conventional processors, which are still widely used in many simple measuring devices. With the aforementioned product families, constant and gapeless measurement takes place. In this case all periods are captured, i.e. measurements are taken during 50 periods out of 50. In parallel to this, the data is processed and the various electrical, PQ and energy parameters are calculated.

It is self-evident that considerably better measurement accuracy is attained. It is also necessary to consider that random measurement can lead to considerable deviations in the measurement results and the energy measurement in the event of rapid load changes (e.g. spot welding).

## Market situation

Simple measuring devices and measuring devices with economical or older measuring electronics are still available for random measurement. If one looks at the global market, random measurement is in fact dominant and remains current engineering practice!

It is also frequently the case that energy is measured constantly, although all other values are not acquired constantly but rather on a random sampling basis.

## Summary

Constant measurement requires higher quality components. By constantly measuring all values, a considerably higher accuracy of measurement is attained.

## Measure, calculate, store – ring buffer was yesterday!

As described in detail in the previous article, our latest generation measuring devices are equipped with highly powerful signal processors (DSP), which enable the constant and seamless determination of current and voltage, as well as the calculation of every conceivable parameter. How does this take place in detail, what is the measuring process sequence, in what form are the measured values made available, where are they saved?

Modern measuring devices such as our UMGs can essentially be considered as PCs. The average elements are the CPU (DSP), RAM, hard drive (flash memory) and communication ports (RS485, RJ45).

It is fundamentally possible to distinguish between the following measured value groups:

### Online values

Online values are determined over a measurement interval of 200 ms or as a mean value of the full wave effective values over 10 periods. Online values are all values that are constantly determined and evaluated by the measuring device. Depending on the measuring device this can be up to 2,000 values available for all measuring channels per 200 ms. The significant values can be read out directly from the UMG displays. Using the GridVis® Power Grid Monitoring Software and working in the topology screen it is possible to view the complete scope of measured values.

All measured values are constantly available in defined Modbus memory registers for external access via suitable third party software.

### Historical values

#### Recordings

Historical values are generated using the online values. For this purpose one or more recording configurations are predefined in the device configuration. For the purpose of the respective recording a period is stipulated for the generation of a mean value, e.g. 15-minute mean value for the recording of load curves, 1-hour mean value for energy, etc. The time frames can lie between 200 ms and multiple days, depending on the type of device. In order to conduct power quality measurements per EN 50160, EN 61000-2-4 or EN 50160, IEEE519, predefined recording configurations are available and these can be activated at the click of a mouse button.

Historical values are generally initially stored in a measuring device on internal flash memory. This was formerly referred to as a ring buffer. Each stored value is assigned a time stamp. Using the GridVis® Power Grid Monitoring Software the values are read out manually or automatically (Service). The measured value and time stamp are stored in a database. Using GridVis® or external database tools it is possible to evaluate these values on a tabular or graphical basis.

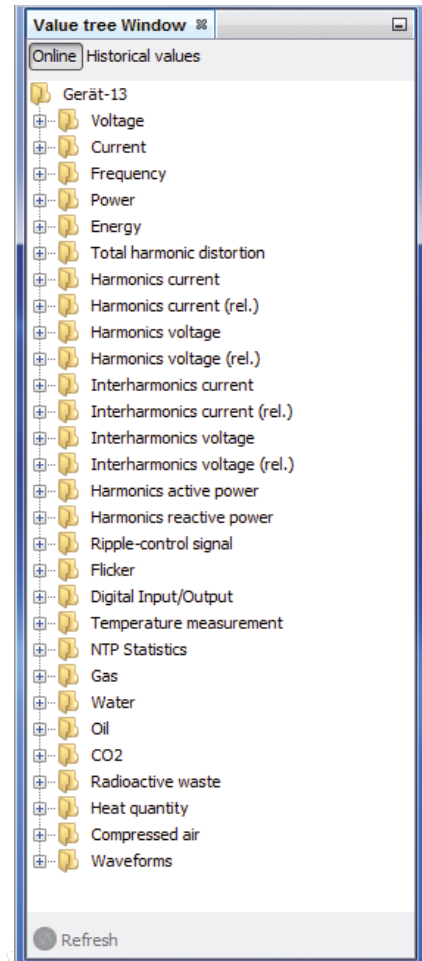


Fig.: Online values, value tree UMG 605-PRO

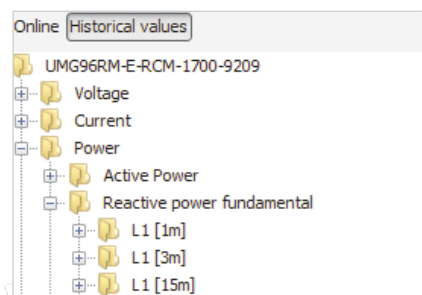


Fig.: Customer-specific historic recordings, value tree UMG 96RM

**Events**

Events are under- and overvoltages as well as overcurrents. The basis is 20-ms full wave effective values with UMG 604-PRO and UMG 509-PRO or 10-ms half wave effective values with UMG 605-PRO and UMG 512-PRO. With an exceeding or undercutting of the stipulated tolerance limits the event is stored on the flash memory. Additionally, a pre- and post event period are defined, so that network incidents can be analysed directly before and after the event occurs. As such, all voltage and current channels are graphically shown as a maximum across the specified time frame.

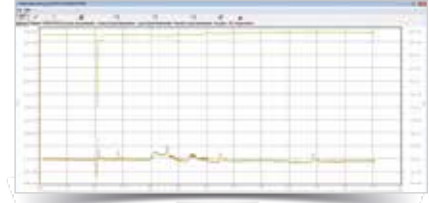


Fig.: Event recording voltage dip / undervoltage

**Transients**

In order to record transients the full performance of the UMGs is required. With a sampling rate of 20 kHz it is possible to capture transients from 50 µs. Similarly with the recording of events, threshold values as well as pre- and post periods can be defined. Likewise, it is also possible to stipulate which channels are written to a graph in waveform at the time that the transients occur.

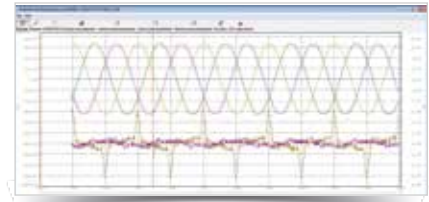


Fig.: Recording transients

**Flags**

Flags are used to mark and save irregularities in measurements and recordings, in accordance with IEC 61000-4-30. In this way it is possible to recognise the causes of gaps in recordings for example.

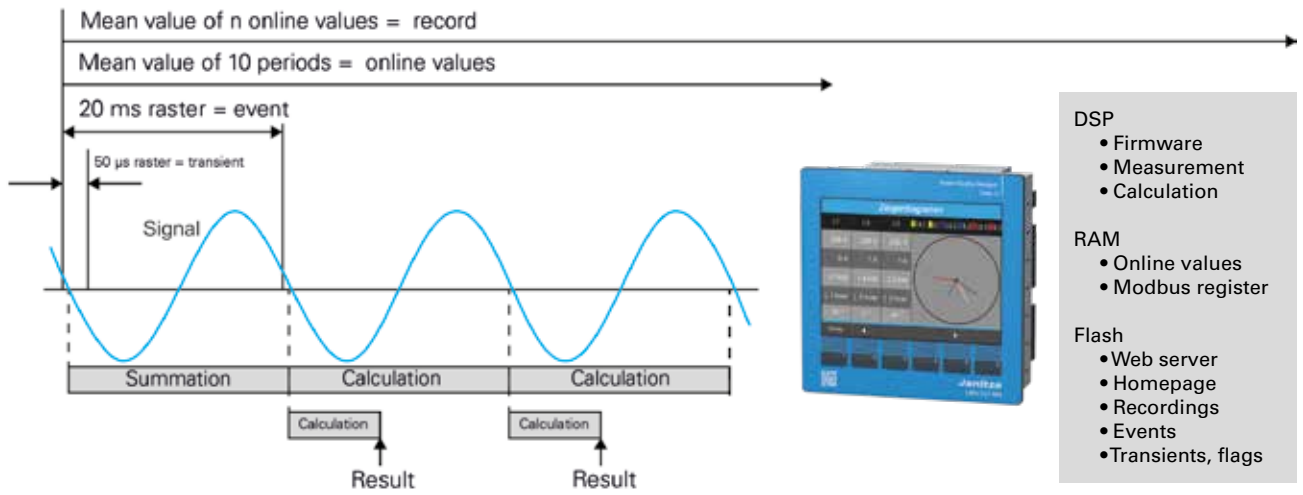
Flag	Note
LostWindow	200 ms measurement window has been lost
LostPLL	The device has lost the grid synchronisation
OverCurrent	Overcurrent A
OverVoltage	Overvoltage V
Firmware upgrade	Firmware upgrade
Initialisation	Buffer initialisation



Fig.: Flag recording

All recordings of historical data, events, transients and flags run constantly, independently of each other and in parallel in the measuring device.

All saved data is historically sorted for storage. If the flash memory is full then the oldest data historically is overwritten. Through the regular reading out of the data to a database, values that are overwritten on the measuring device will already have been saved to the server, meaning that no measured values are lost.



## Collection of formulas (for UMG measurement devices)

**Effective value of the current for phase conductor p**

$$I_p = \sqrt{\frac{1}{N} \cdot \sum_{k=0}^{N-1} i_{pk}^2}$$

**Effective value of the neutral conductor current**

$$I_N = \sqrt{\frac{1}{N} \cdot \sum_{k=0}^{N-1} (i_{1k} + i_{2k} + i_{3k})^2}$$

**Effective voltage L-N**

$$U_{pN} = \sqrt{\frac{1}{N} \cdot \sum_{k=0}^{N-1} u_{pNk}^2}$$

**Effective voltage L-L**

$$U_{pg} = \sqrt{\frac{1}{N} \cdot \sum_{k=0}^{N-1} (u_{gNk} - u_{pNk})^2}$$

**Neutral voltage (vectorial)**

$$U_{\text{Neutral voltage}} = U_{1rms} + U_{2rms} + U_{3rms}$$

**Effective power for phase conductor**

$$P_p = \frac{1}{N} \cdot \sum_{k=0}^{N-1} (u_{pNk} \times i_{pk})$$

**Apparent power for phase conductor p**

- The apparent power is unsigned.

$$S_p = U_{pN} \cdot I_p$$

**Total apparent power (arithmetic)**

- The apparent power is unsigned.

$$S_A = S_1 + S_2 + S_3$$



### Ordinal numbers of harmonics

xxx[0] = Fundamental oscillation (50Hz/60Hz)  
xxx[1] = 2nd harmonic (100Hz/120Hz)  
xxx[2] = 3rd harmonic (150Hz/180Hz)  
etc.

### THD

- THD (Total Harmonic Distortion) is the distortion factor and gives the relationship of the harmonic portions of oscillation to the fundamental oscillation.

### THD for voltage

- M = Ordinal number of harmonics
- M = 50 (UMG 605-PRO, UMG 512-PRO)
- Mains frequency fund equals n = 1

$$THD_U = \frac{1}{|U_{fund}|} \sqrt{\sum_{n=2}^M |U_{n.Harm}|^2}$$

### THD for current

- M = Ordinal number of harmonics
- M = 50 (UMG 605-PRO, UMG 512-PRO)
- Mains frequency fund equals n = 1

$$THD_I = \frac{1}{|I_{fund}|} \sqrt{\sum_{n=2}^M |I_{n.Harm}|^2}$$

### ZHD

- ZHD is the THD for interharmonics
- Is calculated in the device UMG 605-PRO

### Interharmonics

- Sinusoidal form oscillations, whose frequencies are not whole multipliers of the mains frequency (fundamental oscillation)
- Is calculated in the device UMG 605-PRO
- Calculation and measurement processes according to DIN EN 61000-4-30
- The ordinal number of an interharmonic equates to the ordinal number of the next smallest harmonic. For example, the 3rd interharmonic lies between the 3rd and 4th harmonics.

### TDD (I)

- TDD (Total Demand Distortion) gives the relationship between the current harmonics (THDi) and the effective current value with full load.
- IL = Full load current
- M = 50 (UMG 605-PRO, UMG 512-PRO)

$$TDD = \frac{1}{I_L} \sqrt{\sum_{n=2}^M I_n^2} \times 100\%$$

**Ripple control signal U (EN 61000-4-30)**

The ripple control signal U (200 ms measured value) is a voltage measured with a carrier frequency specified by the user. Only frequencies below 3 kHz are taken into consideration.

**Ripple control signal I**

The ripple control signal I (200 ms measured value) is a current measured with a carrier frequency specified by the user. Only frequencies below 3 kHz are taken into consideration.

**Positive-negative-zero sequence component**

- The proportion of voltage or current unbalance in a three-phase system is labelled with the positive, negative and zero sequence components.
- The symmetry of the three-phase system strived for in normal operation is disturbed by unbalanced loads, faults and operating equipment.
  - A three-phase system is referred to as exhibiting symmetry if the three phase conductor voltages and currents are of an equal size and are phase-shifted at 120° to each other. If one or both conditions are not fulfilled then the system is deemed unbalanced. Through the calculation of the symmetrical components comprising positive sequence component, negative sequence component and zero sequence component a simplified analysis of an unbalanced fault in a three-phase system is possible.
- Unbalance is a characteristic of the power quality, for which threshold values have been stipulated in international standards (e.g. EN 50160).

**Positive sequence component**

$$U_{Pos} = \frac{1}{3} \left| U_{L1,fund} + U_{L2,fund} \cdot e^{j\frac{2\pi}{3}} + U_{L3,fund} \cdot e^{j\frac{4\pi}{3}} \right|$$

**Negative sequence component**

$$U_{Neg} = \frac{1}{3} \left| U_{L1,fund} + U_{L2,fund} \cdot e^{-j\frac{2\pi}{3}} + U_{L3,fund} \cdot e^{-j\frac{4\pi}{3}} \right|$$

### Zero sequence component

A zero sequence component can only arise if a total current is able to flow back via the neutral conductor.

$$U_{\text{Zero sequence component}} = \frac{1}{3} |U_{L1,fund} + U_{L2,fund} + U_{L3,fund}|$$

### Voltage unbalance

$$\text{Voltage unbalance} = \frac{U_{\text{Neg}}}{U_{\text{Pos}}}$$

### Downward deviation U (EN 61000-4-30)

$$U_{\text{down}} = \frac{U_{\text{din}} - \sqrt{\frac{\sum_{i=1}^n U_{\text{rms-down},i}^2}{n}}}{U_{\text{din}}} [\%]$$

### Downward deviation I

$$I_{\text{down}} = \frac{I_{\text{Rated current}} - \sqrt{\frac{\sum_{i=1}^n I_{\text{rms-down},i}^2}{n}}}{I_{\text{Rated current}}} [\%]$$

### K factor

- The K factor describes the increase in eddy current losses with a harmonics load. In the case of sinusoidal loading of the transformer the K factor = 1. The greater the K factor, the more heavily a transformer can be loaded with harmonics without overheating.

### Power Factor (arithmetic)

- The power factor is unsigned.

$$PF_A = \frac{|P|}{S_A}$$

### cos phi – Fundamental Power Factor

- Only the fundamental oscillation is used in order to calculate the cos phi
- cos phi sign:
  - = for delivery of effective power
  - + = for consumption of effective power

$$PF_1 = \cos(\varphi) = \frac{P_1}{S_1}$$

**cos phi sum**

- cos phi sign:
  - = for delivery of effective power
  - + = for consumption of effective power

$$\cos(\varphi)_{Sum_3} = \frac{P_{1fund} + P_{2fund} + P_{3fund}}{\sqrt{(P_{1fund} + P_{2fund} + P_{3fund})^2 + (Q_{1fund} + Q_{2fund} + Q_{3fund})^2}}$$

$$\cos(\varphi)_{Sum_4} = \frac{P_{1fund} + P_{2fund} + P_{3fund} + P_{4fund}}{\sqrt{(P_{1fund} + P_{2fund} + P_{3fund} + P_{4fund})^2 + (Q_{1fund} + Q_{2fund} + Q_{3fund} + Q_{4fund})^2}}$$

**Phase angle Phi**

- The phase angle between current and voltage of phase conductor p is calculated and depicted per DIN EN 61557-12.
- The sign of the phase angle corresponds with the sign of the reactive power.

**Fundamental oscillation reactive power**

The fundamental oscillation reactive power is the reactive power of the fundamental oscillation and is calculated with the Fourier analysis (FFT). The voltage and current do not need to be sinusoidal in form. All reactive power calculations in the device are fundamental oscillation reactive power calculations.

**Reactive power sign**

- Sign Q = +1 for phi in the range 0 ... 180 ° (inductive)
- Sign Q = -1 for phi in the range 180 ... 360 ° (capacitive)

$$\text{Sign } Q(\varphi_p) = +1 \text{ if } \varphi_p \in [0^\circ - 180^\circ]$$

$$\text{Sign } Q(\varphi_p) = -1 \text{ if } \varphi_p \in [180^\circ - 360^\circ]$$

**Reactive power for phase conductor p**

- Reactive power of the fundamental oscillation

$$Q_{fundp} = \text{Sign } Q(\varphi_p) \cdot \sqrt{S_{fundp}^2 - P_{fundp}^2}$$

### Total reactive power

- Reactive power of fundamental oscillation

$$Q_V = Q_1 + Q_2 + Q_3$$

### Distortion reactive power

- The distortion reactive power is the reactive power of all harmonics and is calculated with the Fourier analysis (FFT).
- The apparent power S contains the fundamental oscillation and all harmonic portions up to the Mth harmonic.
- The effective power P contains the fundamental oscillation and all harmonic portions up to the Mth harmonic.
- M = 50 (UMG 605-PRO, UMG 512-PRO)

$$D = \sqrt{S^2 - P^2 - Q_{fund}^2}$$

### Reactive energy per phase

$$E_{r_{L1}} = \int Q_{L1}(t) \cdot \Delta t$$

### Reactive energy per phase, inductive

$$E_{r(ind)_{L1}} = \int Q_{L1}(t) \cdot \Delta t \quad \text{for } Q_{L1}(t) > 0$$

### Reactive energy per phase, capacitive

$$E_{r(cap)_{L1}} = \int Q_{L1}(t) \cdot \Delta t \quad \text{for } Q_{L1}(t) < 0$$

### Reactive energy, sum L1-L3

$$E_{r_{L1,L2,L3}} = \int (Q_{L1}(t) + Q_{L2}(t) + Q_{L3}(t)) \cdot \Delta t$$

**Reactive energy, sum L1-L3, inductive**

$$E_{r(ind)_{L1,L2,L3}} = \int (Q_{L1}(t) + Q_{L2}(t) + Q_{L3}(t)) \cdot \Delta t$$

for  $Q_{L1}(t) + Q_{L2}(t) + Q_{L3}(t) > 0$

**Reactive energy, sum L1-L3, capacitive**

$$E_{r(cap)_{L1,L2,L3}} = \int (Q_{L1}(t) + Q_{L2}(t) + Q_{L3}(t)) \cdot \Delta t$$

for  $Q_{L1}(t) + Q_{L2}(t) + Q_{L3}(t) < 0$

## General information on current transformers

### General information

Current transformers are predominantly utilised in areas in which it is not possible to measure current directly. They are a special type of transformer with a defined degree of precision (class), which translates the primary current into a (usually) smaller, standardised secondary current, as well as galvanically separating primary and secondary circuits from each other. The physical saturation (especially with monitoring CTs) of the core material additionally guarantees protection of the secondary circuit from higher currents.

It is fundamentally possible to distinguish between single-phase current transformers and winding current transformers. The most frequent form of single-phase current transformer is the moulded case feed through current transformer, which is plugged onto the current-carrying phase and therefore forms a transformer with primary winding (and secondary windings in accordance with the transformation ratio).



Fig.: Feedthrough CTs

## Selecting current transformers

### Transformation ratio

The transformation ratio is the relationship between the primary rated current and the secondary rated current, and is cited on the rating plate as an unsimplified fraction.

Most frequently,  $x / 5$  A current transformers are used. The majority of measuring devices have the highest precision class at 5 A. For technical and moreover economic reasons,  $x / 1$  A current transformers are recommended with long measuring cable lengths. The line losses with 1-A transformers is only 4 % in comparison to 5-A transformers. However, the measuring devices here frequently exhibit a lower accuracy of measurement.

### Rated current

Rated or nominal current (earlier designation) is the value of the primary and secondary current cited on the rating plate (primary rated current, secondary rated current), for which the current transformer is dimensioned. Standardised rated currents are (apart from in the classes 0.2 S and 0.5 S) 10 – 12.5 – 15 – 20 – 25 – 30 – 40 – 50 – 60 – 75 A, as well as the decimal multiples and fractions thereof. Standardised secondary currents are 1 and 5 A, preferably 5 A.

Standardised rated currents for the classes 0.2 S and 0.5 S are 25 – 50 – 100 A and their decimal multiples, as well as secondary (only) 5 A.

Correct selection of the primary nominal current is important for the accuracy of measurement. Recommended is a ratio slightly beyond the measured / defined maximum load current ( $I_n$ ).

Example:  $I_n = 1,154 \text{ A}$ ; selected transformer ratio = 1,250/5.

The nominal current can also be defined on the basis of the following considerations:

- Dependent on the mains supply transformer nominal current times approx. 1.1 (next transformer size)
- Protection (rated fuse current = CT primary current) of the measured system part (LVDSB, subdistribution boards)
- Actual nominal current times 1.2 (if the actual current lies considerably below the transformer or fuse nominal current then this approach should be selected)

Over-dimensioning the current transformer must be avoided, otherwise the accuracy of measurement significantly decrease especially with small load currents.

**Rated power**

The rated power of the current transformer is the product of the rated load and the square of the secondary rated current and is quoted in VA. Standardised values are 2.5 – 5 – 10 – 15 – 30 VA. It is also permissible to select values over 30 VA according to the application case. The rated power describes the capacity of a current transformer to "drive" the secondary current within the error limits through a load.

When selecting the appropriate power it is necessary to take into consideration the following parameters: Measuring device power consumption (with connection in series), line length, line cross-section. The longer the line length and the smaller the line cross-section, the higher the losses through the supply, i.e. the nominal power of the CT must be selected such that this is sufficiently high.

The power consumption should lie close to the transformer's rated power. If the power consumption is very low (underloading) then the overcurrent factor will increase and the measuring devices will be insufficiently protected in the event of a short circuit under certain circumstances. If the power consumption is too high (overloading) then this has a negative influence on the accuracy.

Current transformers are frequently already integrated in an installation and can be used in the event of retrofitting with a measuring device. It is necessary to note the nominal power of the transformer in this case: Is this sufficient to drive the additional measuring devices?

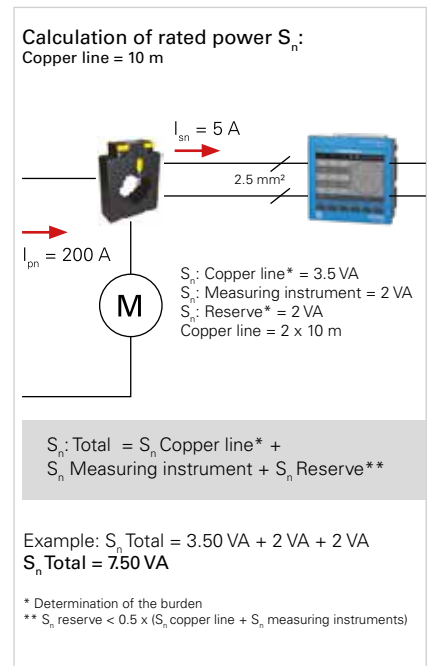


Fig.: Calculation of the rated power  $S_n$   
(Copper line 10 m)



### Precision classes

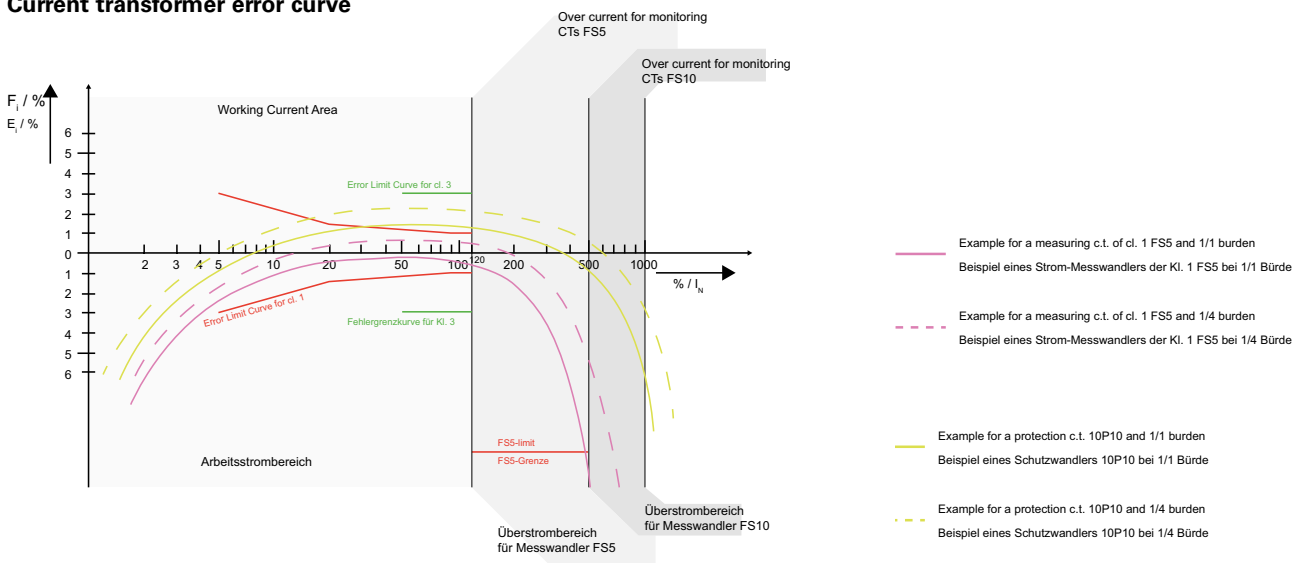
Current transformers are divided up into classes according to their precision. Standard precision classes are 0.1; 0.2; 0.5; 1; 3; 5; 0.1 S; 0.2 S; 0.5 S. The class sign equates to an error curve pertaining to current and angle errors.

The precision classes of current transformers are related to the measured value. If current transformers are operated with low current in relation to the nominal current then the accuracy of measurement declines. The following table shows the threshold error values with consideration to the nominal current values:

Precision class	Current fault $F_j$ in % with % of the rated current							
	1 %	5 %	20 %	50 %	100 %	120 %	150 %	200 %
5				5		5		
3				3		3		
1		3	1.5		1	1		
1 ext 150		3	1.5		1		1	
1 ext 200		3	1.5		1			1
0.5		1.5	0.75		0.5	0.5		
0.5 S	1.5	0.75	0.5		0.5	0.5		
0.5 ext 150		1.5	0.75		0.5		0.5	
0.5 ext 200		1.5	0.75		0.5			0.5
0.2		0.75	0.35		0.2	0.2		
0.2 S	0.75	0.35	0.2		0.2	0.2		

We always recommend current transformers with the same precision class for the UMG measuring devices. Current transformers with a lower precision class lead in the complete system – current transformer + measuring device – to a lower accuracy of measurement, which is defined in this case by the precision class of the current transformer. However, the use of current transformers with a lower accuracy of measurement than the measuring device is technically feasible.

### Current transformer error curve



**Measurement current transformer vs. protection current transformer**

Whilst measurement current transformers are intended to reach saturation point as quickly as possible once they exceed their operational current range (expressed by the overcurrent factor FS) – in order to avoid an increase in the secondary current with a fault (e.g. short circuit) and to protect the connected devices. With protection transformers saturation should lie as far out as possible.

Protection transformers are used for system protection in conjunction with the requisite switchgear. Standard precision classes for protection transformers are 5P and 10P. "P" stands for "protection" here. The nominal overcurrent factor is placed after the protection class designation (in %). Therefore, 10P5 for example means that with a five-fold nominal current the negative secondary-side deviation from the anticipated value will be no more than 10% according to the ratio (linear).

The use of measurement current transformers is strongly recommended for the operation of UMG measuring devices.

**Standard current transformer bus bar**

Type	Primary currents in A	Bus bar sizes in mm
<b>Feedthrough current transformer</b>		
IPA40	50 - 75	40 x 10 30 x 15 25 x 20
IPA40.5	50 - 100	40 x 10 30 x 15 25 x 20
6A315.3	100 - 600	30 x 15 20 x 20
7A412.3	800 - 1000	40 x 12 2 x 30 x 10
8A512.3	1250 - 1500	50 x 12 2 x 40 x 10
9A615.3	1000 - 2500	63 x 15 2 x 50 x 10
<b>Split core current transformer</b>		
Split-100	100	2 x 60 x 10 60 x 35
Split-150	150	2 x 60 x 10 60 x 35
Split-200	200	2 x 60 x 10 60 x 35
Split-250	250	2 x 60 x 10 60 x 35
Split-300	300	2 x 60 x 10 60 x 35
Split-400	400	2 x 60 x 10 60 x 35
Split-500	500	2 x 60 x 10 60 x 35
Split-600	600	2 x 60 x 10 60 x 35
Split-750	750	2 x 60 x 10 60 x 35
Split-800	800	2 x 60 x 10 60 x 35
Split-1000	1,000	2 x 80 x 10 60 x 32
Split-1200	1,200	2 x 80 x 10 60 x 32
Split-1250	1,250	2 x 80 x 10 60 x 32

Split-1500	1,500	2 x 80 x 10 60 x 32
Split-1600	1,600	2 x 80 x 10 60 x 32
Split-2000	2,000	2 x 80 x 10 60 x 32
<b>Special version</b>		
Deviating primary rated current	On request	
Deviating secondary rated current	On request	
Deviating construction type	On request	
Deviating rated frequency	On request	
Expanded class precision and load durability	On request	
Type-approved / calibrated transformer	On request	

## Current transformer construction types

### Moulded case feedthrough current transformer

The phase to be measured (conductor rail or line) is fed through the CT window and forms the primary circuit for the current transformer. Feedthrough transformers are predominantly used for mounting on bus bars. Through additional potting it is possible to achieve droplet-tightness, as well as greater shock and vibration resistance with mechanical loading (IEC 68). This is the most common form of current transformers, with the disadvantage that the primary conductor must be interrupted during installation. This form of transformer is therefore most commonly used in new system installations.

### Split core current transformer

Split core current transformers are frequently used with retrofit applications. With these transformers the transformer core is open ready for installation, and is therefore fitted around the bus bars. This enables installation without interrupting the primary conductor.



Fig.: Split core current transformer

### Cable type split core current transformer

Cable type split core current transformers are exclusively suitable for installation in isolated primary circuit conductors (supply cables) in weatherproof and dry locations. Installation is possible without interrupting the primary conductor (i.e. with ongoing operation).

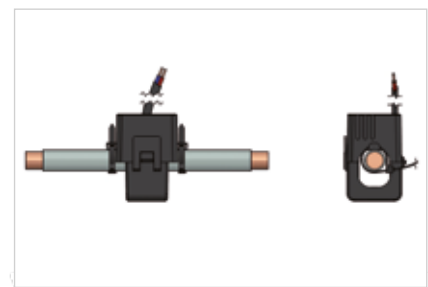


Fig.: Cable type split core current transformer

**DIN rail current transformer with voltage tap and fuse**

The DIN rail current transformer is a highly compact special variant with integrated voltage tap. The DIN rail current transformer comprises a terminal strip, current transformer and the voltage tap terminal with fuse. The fuse is fitted directly on the primary conductor and the unprotected part of the measurement line is therefore very short. This guarantees a high degree of intrinsic safety.

The DIN rail current transformer is simple to wire, results in low installation costs and a high degree of reliability due to few connections, and is also space-efficient and exhibits only very few connection faults.



Fig.: DIN rail current transformer

# Installation of current transformers

**Installation orientation**

Determine the flow direction of the energy in the cable that you wish to measure. P1 indicates the side on which the current source is located, whilst P2 indicates the load side.

**Terminals S1/S2 (k/l)**

The connections of the primary winding are designated "K" and "L" or "P1" and "P2", and the connections of the secondary winding are designated "k" and "l" or "S1" and "S2". The polarity must be established such that the "flow direction of the energy" runs from K to L.

Inadvertently swapping the terminals S1/S2 leads to erroneous measurement results and can also cause incorrect control behaviour with PFC systems.

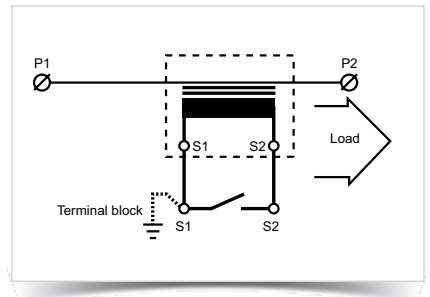


Fig.: Installation orientation

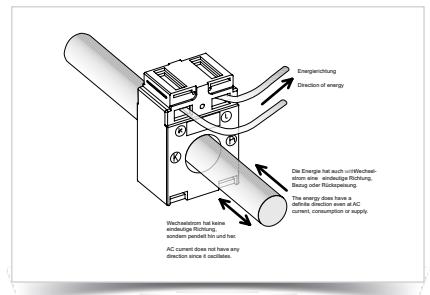


Fig.: Installation orientation of current transformers

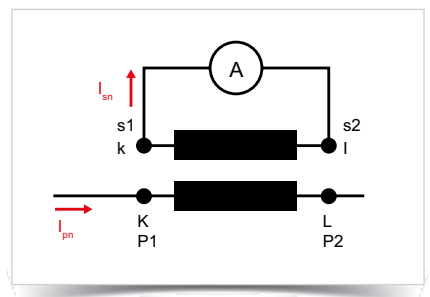


Fig.: Direction of energy flow

### Line length and cross-section

The power consumption (in W) caused by the line losses is calculated as follows:

$$P = \frac{\rho \times l \times I^2}{A}$$

- specific resistance  
for CU: 0.0175 Ohm \* mm<sup>2</sup> / m  
for Al: 0.0278 Ohm \* mm<sup>2</sup> / m

L = Line length in m (outward and return line)

I = Current in Amperes

A = Line cross-section in mm<sup>2</sup>

### Brief overview (power consumption copper line) for 5 A and 1 A:

With every temperature change of 10 °C the power consumed by the cables increases by 4 %.

Power consumption in VA at 5 A										
Nominal cross-section	1 m	2 m	3 m	4 m	5 m	6 m	7 m	8 m	9 m	10 m
2.5 mm <sup>2</sup>	0.36	0.71	1.07	1.43	1.78	2.14	2.50	2.86	3.21	3.57
4.0 mm <sup>2</sup>	0.22	0.45	0.67	0.89	1.12	1.34	1.56	1.79	2.01	2.24
6.0 mm <sup>2</sup>	0.15	0.30	0.45	0.60	0.74	0.89	1.04	1.19	1.34	1.49
10.0 mm <sup>2</sup>	0.09	0.18	0.27	0.36	0.44	0.54	0.63	0.71	0.80	0.89

Power consumption in VA at 1 A										
Nominal cross-section	10 m	20 m	30 m	40 m	50 m	60 m	70 m	80 m	90 m	100 m
1.0 mm <sup>2</sup>	0.36	0.71	1.07	1.43	1.78	2.14	2.50	2.86	3.21	3.57
2.5 mm <sup>2</sup>	0.14	0.29	0.43	0.57	0.72	0.86	1.00	1.14	1.29	1.43
4.0 mm <sup>2</sup>	0.09	0.18	0.27	0.36	0.45	0.54	0.63	0.71	0.80	0.89
6.0 mm <sup>2</sup>	0.06	0.12	0.18	0.24	0.30	0.36	0.42	0.48	0.54	0.60
10.0 mm <sup>2</sup>	0.04	0.07	0.11	0.14	0.18	0.21	0.25	0.29	0.32	0.36

Example of current transformer capacity and line length					
Secondary current = 1 A Line = 0.75 mm <sup>2</sup> Current transformer capacity / line length			Secondary current = 5 A Line = 2.5 mm <sup>2</sup> Current transformer capacity / line length		
Class 0.5	Class 1	Class 3	Class 0.5	Class 1	Class 3
0.5 VA / 5 m	0.5 VA / 5 m	0.25 VA / 1 m	0.5 VA / 0.7 m	0.5 VA / 0.7 m	0.5 VA / 0.7 m
1 VA / 15 m	1 VA / 15 m	0.5 VA / 5 m	1 VA / 2.1 m	1 VA / 2.1 m	1.5 VA / 3.5 m
2.5 VA / 47 m	1.5 VA / 26 m	1 VA / 15 m	2.5 VA / 6 m	2.5 VA / 6 m	2.5 VA / 6 m
5 VA / 100 m	2.5 VA / 47 m	1.5 VA / 26 m	5 VA / 13 m	5 VA / 13 m	
10 VA / 205 m	5 VA / 100 m			10 VA / 27 m	
	10 VA / 200 m			20 VA / 55 m	
	20 VA / 400 m				

### Serial connection of measuring devices to a current transformer

$$P_v = U_{MG\ 1} + U_{MG\ 2} + \dots + P_{Line} + P_{Terminals} \dots?$$

**Operation in parallel / summation current transformer**

If the current measurement is carried out via two current transformers, the overall transformer ratio of the current transformers must be programmed into the measuring device.

Example: Both current transformers have a transformer ratio of 1,000/5A.  
The total measurement is carried out using a summation current transformer 5+5 / 5 A.

The UMG must then be set up as follows:

Primary current: 1,000 A + 1,000 A = 2,000 A  
Secondary current: 5 A

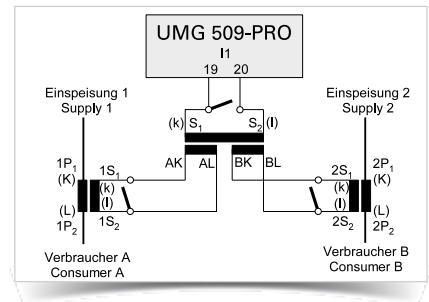


Fig.: UMG 509-PRO current measurement via summation transformer

**Grounding of current transformers**

According to VDE 0414, current and voltage transformers should be secondary grounded from a series voltage of 3.6 kV. With low voltage it is possible to dispense with grounding if the current transformers do not possess large metal contact surfaces. However, common practice is to ground low voltage transformers too. Customary is grounding on S1. However, grounding can also take place on the S1(k) terminal or S2(k) terminals. Important: Always ground on the same side!

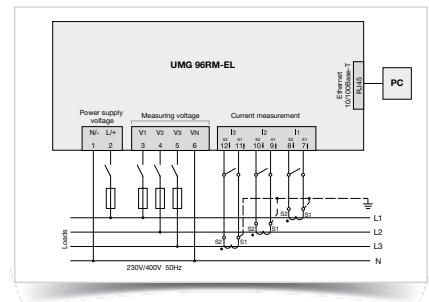


Fig.: Connection example UMG 96RM-EL

**Use of protection current transformers**

In the event of retrofitting a measuring device and the exclusive availability of a protective core, we recommend the use of a winding current transformer 5/5 for decoupling the protective core.

# Operation of current transformers

## Exchanging a measuring device (short-circuiting of current transformers)

The current transformer secondary circuit should never be opened when current is flowing into the primary circuit.

The current transformer output constitutes a current source. With an increasing burden the output voltage therefore increases (according to the relationship  $U = R \times I$ ) until saturation is reached. Above saturation point the peak voltage continues to rise with increasing distortion, and attains its maximum value with an endless burden, i.e. open secondary terminals. With open transformers it is therefore possible that voltage peaks may arise, which could pose a risk of danger to persons and may also destroy measuring devices when reconnected.

It is therefore the case that open operation of CTs must be avoided and unloaded current transformers must be short circuited.

## Current transformer terminal block with short circuit devices

In order to short circuit current transformers and for the purpose of recurrent comparative measurements it is recommended that special terminal block for DIN rails be used. These comprise a cross-disconnect terminal with measuring and test equipment, insulated bridges for grounding and short circuiting of the current transformer terminals.



Fig.: Current transformer terminal block

## Overloading of measurement CTs

Primary current overloading:

Primary current too high --> Saturation of the core material --> Precision declines dramatically.

Nominal power overloading:

Too many measuring devices or excessively long lines are connected to a transformer with its defined nominal power --> Saturation of the core material --> Precision declines dramatically.

## Instance of short circuit at CT secondary side

In the event of a short circuit no signal is available. It is not possible to measure with the measuring device. Current transformers can (or must) be short circuited if no load is present (measuring device).

**Operation with harmonics**

Our current transformers generally measure harmonics up to 2.5 kHz (50th harmonic) and many types also measure to 3 kHz and even beyond. However, with higher frequencies the eddy current losses increase and heating up is consequently also greater. If the total harmonic distortion is too high then the current transformer must be designed with thinner sheets.

However, it is not possible to make a general statement regarding a threshold value of the total harmonic distortion because heating up is dependent on core size, transformer surface (cooling), ambient temperature, ratio, etc.

**Power requirement UMGs, energy meter, measuring devices**

Measuring device type	Power consumption current measurement input in VA
Analogue ammeter	1.1
UMG 103-CBM / 604-PRO / 605-PRO	0.2
UMG 96RM	0.2
UMG 96RM-E	0.2
UMG 509-PRO	0.2
UMG 512-PRO	0.2
ECSEM series energy meter	0.36

**Power consumption UMG 96RM-E per current measurement input**

UMG 96RM-E	0.2 VA
	+
4 metre 2-wire line 2.5 mm <sup>2</sup>	1.64 VA
	=
Gives the power consumption of the measuring equipment the CT has to be rated for	1.84 VA

**The special case: Larger current transformer – lower current**

**Tip:**

Select a current transformer that is suitable for the measurement of a nominal current of 50 A.

In order to divide the normal current of a current transformer by two it is actually sufficient to run this current through the transformer twice.





## Overvoltage categories

Electrical distribution systems and loads are becoming increasingly complex. This also results in the likelihood of transient overvoltage increasing. Power electronic modules in particular (e.g. frequency converters, phase angle and trailing-edge control, PWM-controlled power switches) generate temporary voltage peaks in conjunction with inductive loads, which can be significantly higher than the respective nominal voltage. In order to guarantee user safety, four overvoltage categories (CAT I to CAT IV) are defined in DIN VDE 0110 / EN 60664.

The measurement category indicates the permissible application ranges of measuring and test devices for electrical operating equipment and systems (e.g. voltage testers, multimeters, VDE test devices) for application in low voltage network areas.

### Defined categories and application purposes in IEC 61010-1:

The following categories and application purposes are defined in IEC 61010-1:	
<b>CAT I</b>	Measurements on current circuits that have no direct connection to the mains network (battery operation), e.g. devices in protection class 3 (operation with protective low voltage), battery-operated devices, car electrics
<b>CAT II</b>	Measurements on current circuits that have a direct connection by means of a plug with the low voltage network, e.g. household appliances, portable electrical appliances
<b>CAT III</b>	Measurements within the building installation (static loads with direct fixed connection, distribution connection, fixed installation appliances in the distribution system), e.g. sub-distribution.
<b>CAT IV</b>	Measurements at the source of the low voltage installation (meter, main connection, primary overcurrent protection), e.g. revenue meters, low voltage overhead lines, utility service entrance box

The category is particularly significant for safety during measurements, because low-resistance current circuits exhibit higher short circuit currents and / or the measuring device is also required to withstand disturbances in the form of load switching and other transient overvoltages, without the user being endangered by electric shocks, fire, sparks forming or explosions. Due to the low impedance of the public grid, short circuit currents are at their greatest at the house infeed. Inside the home, the maximum short circuit currents are reduced through the system's series impedances. Technically, compliance with the category is ensured for example through the contact protection of plugs and sockets, insulation, sufficient clearance and creepage distances, the strain relief and kink protection of cables, as well as sufficient cable cross-sections.

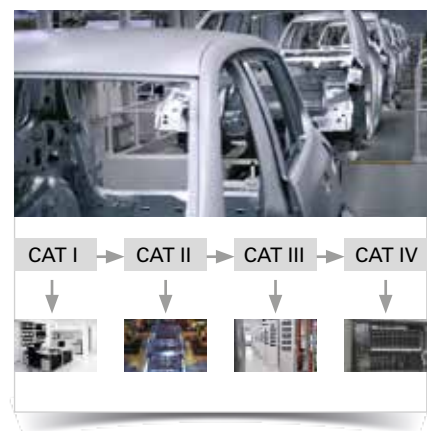


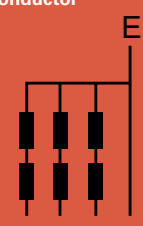



Fig.: Graphic illustration of the CAT categories

**In practice**

Our experience and understanding shows that many users are not sufficiently familiar with this subject. In some applications, the subject of overvoltage categories may result in a need to change from a UMG 604-PRO with 300V CAT-III to a UMG 509-PRO with the overvoltage category 600 V CATIII, i.e. instead of a 4,000-V measurement voltage surge, a 50 % higher measurement voltage surge of 6,000 V is attained! However, it may also result in the shifting of the measurement point. This means additional safety for man and machine!

The combination of the CAT category and the defined voltage level gives the measurement voltage surge.

**Rated voltages of power supply systems (networks) with various types of overvoltage limitation**

Voltage conductor to neutral conductor, taken from rated AC voltage or rated DC voltage up to and including	Rated voltages presently in use worldwide				Measurement voltage surge for operating equipment			
	Three-phase 4-conductor systems with grounded neutral conductor	Three-phase 3-conductor systems, ungrounded	Single-phase 2-conductor systems, AC or DC voltage	Single-phase 3-conductor systems, AC or DC voltage	Overvoltage categories			
V								
V	V	V	V	V	I	II	III	IV
150	120 / 208* 127 / 220	115, 120, 127	100** 110, 220	100 – 200** 101 – 220 120 – 240	800	1,500	2,500	4,000
300	220 / 380, 230 / 400 240 / 415, 260 / 440 277 / 480	200**, 220, 230, 240, 260, 277, 347, 380, 400, 415, 440	220	220 – 400	1,500	2,500	4,000	6,000
600	347 / 600, 380 / 660 400 / 690, 417 / 720	500	480	480 – 960	2,500	4,000	6,000	8,000

\* Conventional in the United States of America and Canada.  
\*\* Conventional in Japan.

## Communication via the RS485 interface

If it is necessary to network economical measuring devices with each other, the RS485 interface with Modbus RTU protocol remains the benchmark. The simple topology configuration, the lack of sensitivity to EMC interference and the open protocol have been outstanding features of the combination of RS485 and Modbus RTU protocol for years. The full name of the RS485 standard is TIA / EIA-485-A. The most recent update was in March 1998 and the standard was confirmed in 2003 without changes. The standard only defines the electrical interface conditions of the sender and receiver, it does not say anything about the topology or the lines to be used. This information can either be found in the TSB89 "Application Guidelines for TIA / EIA-485-A" or in the application descriptions of the RS485 driver module manufacturers, such as Texas Instruments or Maxim. According to the OSI model (Open Systems Interconnection Reference Model)\* only the "physical layer" and not the protocol is described. The protocol used may be selected on an arbitrary basis, e.g. Modbus RTU, Profibus, BACnet etc. The communication between the sender and receiver takes place on a wired basis via shielded, twisted pair cable. One cable pair should only ever be used here for A and B (Fig.: Image 1b). If the interface is not galvanically separated then the common connection must also be routed with it (Fig.: Image 1b). More on this later.

The transfer of data takes place via a differential, serial voltage signal between lines [A] and [B]. Because data is transferred on the lines between sender and receiver, one also refers here to half-duplex or alternating operation. Each receiver or sender has an inverted and a non-inverted connection. The data transfer takes place symmetrically. This means that if one line has a "high" signal then the other has a "low" signal. Line A is therefore complementary to B and vice versa. The advantage of measuring the voltage difference between A and B is that common mode interference has largely no influence. Any common mode interference is coupled on both signal lines approximately equally, and due to the differential measurement it therefore has no influence on the data that is to be transferred. The sender (driver) generates a differential output voltage of **at least 1.5 V** at 54 Ohm load. The receiver has a sensitivity of +/-200 mV (Fig. Image 2).

**The logic here is as follows (Fig. Image 3):**

A-B < 0.25 V = Logic 1  
A-B > 0.25 V = Logic 0

The labelling of connections A / B is often not uniform. What is A with one manufacturer, may be B with the next. Why is this the case?

**The definition says:**

A = "-" = T x D- / R x D- = inverted signal  
B = "+" = T x D+ / R x D+ = non-inverted signal

Furthermore, a third line "C" = "Common" is also cited. This line is for the reference ground.

Fig.: Image 1a

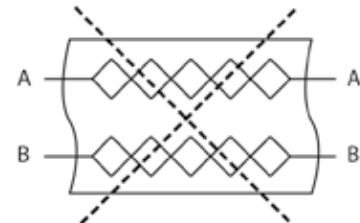


Fig.: Image 1b

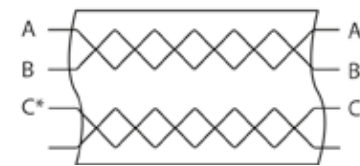


Fig.: Image 1

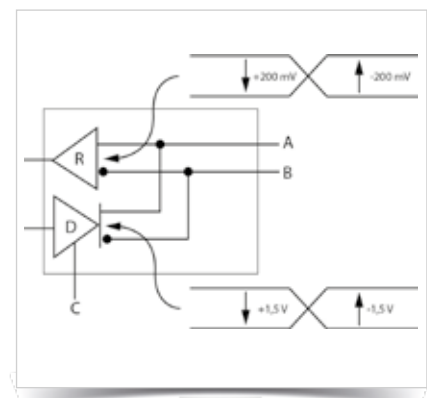


Fig.: Image 2

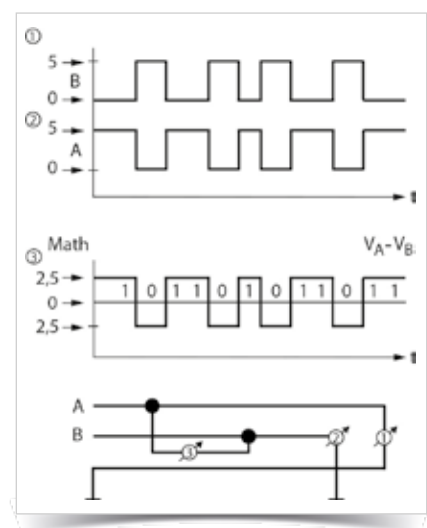


Fig.: Image 3

\* Open Systems Interconnection Reference Model (OSI): Driver = Sender; Receiver = Recipient; Transceiver = Sender / Receiver

However, some RS485 chip manufacturers such as Texas Instruments, Maxim, Analog Devices etc. have always used an alternative designation, which has since also become commonplace:

A = "+" = T x D + / R x D + = non-inverted signal  
 B = "-" = T x D - / R x D - = inverted signal

Due to this confusion, some device manufacturers have introduced their own designations:

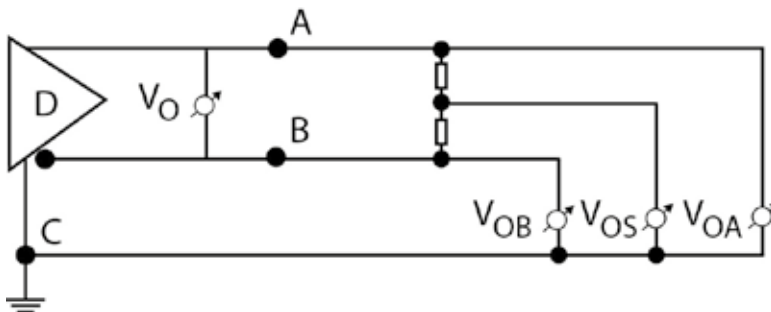
D+ = "+" = T x D + / R x D + = non-inverted signal  
 D- = "-" = T x D - / R x D - = inverted signal

Through the [+] and [-] sign after the letter [D] it is clear which line is providing the inverted and the non-inverted signal.

**Janitza electronics GmbH** predominantly uses transceiver ICs from Texas Instruments, Analog Devices or Maxim. For this reason, all of our measuring devices utilise the following designations:

A = "+" = T x D + / R x D + = non-inverted signal  
 B = "-" = T x D - / R x D - = inverted signal

**The voltages are defined in the datasheets as follows:**



$V_O$  = Differential voltage A – B  
 $V_{OB}$  = Voltage between B and C  
 $V_{OA}$  = Voltage between A and C  
 $V_{OS}$  = Driver offset voltage

Fig.: Image 4

### The voltage VCM

The voltage VCM (Common Mode Voltage) is the sum of the GND potential differences between the RS485 participants (Fig.: Image 5), the driver offset voltage and the common mode noise (Vnoise), acting on the bus line. The RS485 driver manufacturers give a voltage range for VCM of -7 to 12 V. With communication problems, this voltage range - resulting from the potential differences between sender and receiver - is frequently impeded if the interface is not galvanically separated by configuration or no common line exists. Image 6 shows the calculation of the common mode voltage.

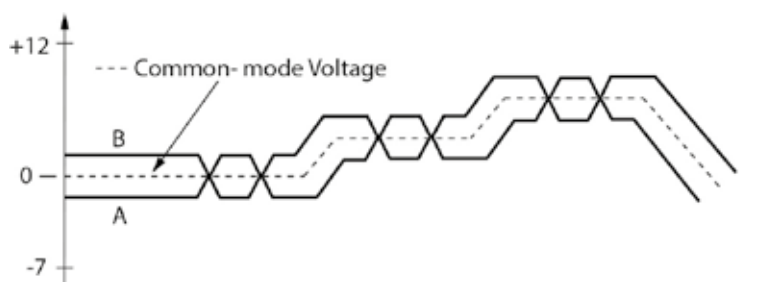


Fig.: Image 5

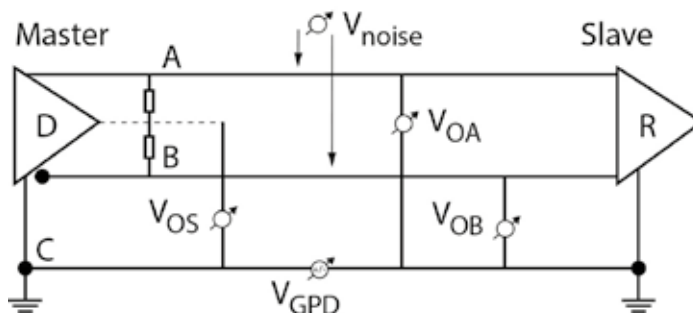


Fig.: Image 6

$$V_{OS} = \frac{V_{OA} + V_{OB}}{2}$$

$$V_{CM} = V_{OS} + V_{noise} + V_{GPD}$$

### $V_{GPD}$ (Ground potential differences)

$V_{GPD}$  is the potential difference between sender and receiver here GND (PE). Potential differences between the connections (grounding) often arise with larger spatial expansion of the RS485 bus. These potential differences arise in particular with older electrical installations, because no intermeshed potential equalisation exists in many cases. Furthermore, the effects of lightning result in the potential difference between the PE connections in the distribution system approaching hundreds or thousands of volts. It is also possible under normal conditions that potential differences of a few volts may exist due to the equalisation currents of the loads. Vnoise (common mode noise) is an interference voltage that can have the following causes:

- Interference voltage induced by a magnetic field on the bus line

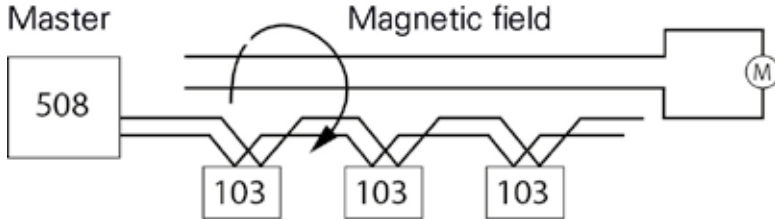


Fig.: Image 7

- Capacitive coupling with system parts that are not galvanically separated ("parasitic capacities")

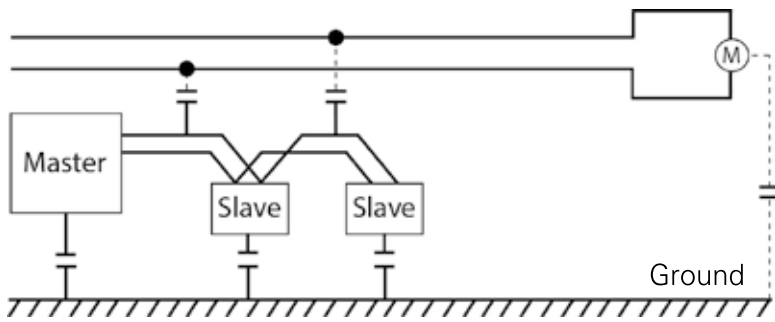


Fig.: Image 8

- Galvanic coupling
- Radiant coupling
- Electrostatic discharge

### Bus topology

The bus is "multipoint-capable" and it is possible to connect up to 32 participants without a repeater. The best network topology here is the "daisy chain". This means that the bus cable runs directly from slave to slave.

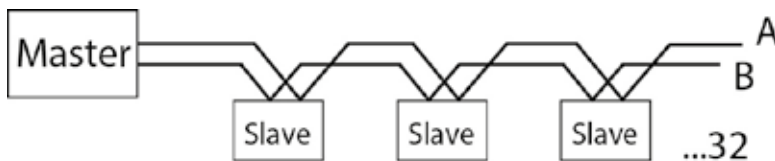


Fig.: Image 9

It is necessary to note that stub lines (branches) should be avoided in general. Stub lines cause reflections on the bus. In theory it is feasible to calculate a possible stub line depending on the transceiver used. However, this is complex in practice. The length of a possible stub line is heavily dependent on the signal rise time of the transceiver used and should be less than 1/10 of the signal rise time of the driver. The higher the possible Baud rate of the transceiver, the

smaller the signal rise time of the driver. This means one must know which IC has been installed with the bus participants. Furthermore, the signal speed of the cable must also be applied in the calculation. For this reason, one should avoid stub lines in general.

### Termination

A further cause of communication interruptions are bus reflections. A reflection arises if the sender signal has not been fully absorbed by the load. The source impedance should reflect the load impedance and the line surge impedance, because the full signal power is attained through this and only minimum reflections arise. Serial communication of the RS485 interface functions most efficiently when the source and load impedance are harmonised at 120 Ohm. For this reason, the RS485 standard recommends a bus line with a line surge impedance of  $Z_0 = 120 \text{ Ohm}$ . In order that reflections are avoided on the bus, the bus line must be equipped with a termination resistor at the start and end, and this must reflect the line surge impedance.

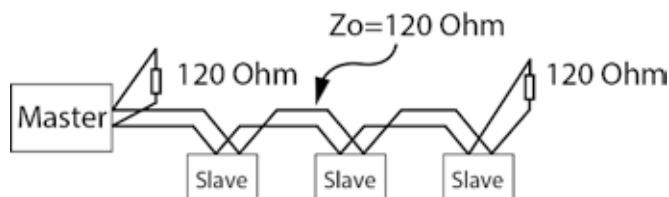


Fig.: Image 10

### "Failsafe Bias" resistors

If the receiver inputs fall within the range of  $-200 \text{ mV}$  to  $+200 \text{ mV}$ , the output of the receiver module is undetermined, i.e. it is not possible for an evaluation of the RS485 signal to take place.

#### This is the case under the following conditions:

- No sender active
- The bus line has been interrupted (e.g. line break)
- The bus line has short circuited (e.g. line damaged, etc.)

Under these conditions the RS485 bus must be brought to a defined signal status. Some communication buses do not have this problem because only one sender exists for example, which controls the line. The sender is either active or inactive. However because the RS485 bus is multipoint-capable, multiple senders can be connected.

In order that the signal status is clear under the aforementioned conditions, one generally uses a "pull up" resistor between  $+5\text{V}$  and the signal line A and a "pull down" resistor between GND and signal line B. The resistors can theoretically be placed at an arbitrary point in the bus. However, these are generally used with a master in a potential divider group with termination resistor because readily assembled connectors exist for this purpose.

With some manufacturers one generally only finds a recommendation to install a termination resistor at the start and end, in order that reflections can be avoided (see section on termination or bus configuration UMG 604-PRO with UMG 103-CBM). Why is this the case?

In this case the manufacturers have used transceivers for the RS485 interface, which already have an integrated internal Failsafe Bias in the chip, i.e. with 0 V at the receiver input for example, the output automatically has a logical "High" state. With Maxim (as used in the UMG 604-PRO and UMG 103-CBM) the function is called "True fail-safe". An external Failsafe Bias then only remains necessary if participants are connected to the same bus, which do not possess this function. The bus load is otherwise unaffected by the "True fail-safe" function.

### **The "common connection" or "galvanic separation"**

The bus participants generally obtain their supply voltage from different areas of the electrical installation. With older electrical installations in particular, it is therefore possible that considerable potential differences can arise between grounding. However, for fault-free communication the voltage  $V_{cm}$  can only lie within the range of -7 to +12 V, i.e. the voltage  $V_{GPD}$  (Ground potential differences) must be as small as possible (image 11 a, image 5). If the RS485 interface is not galvanically separated from the supply voltage then the common connection must be routed with it (image 11 b). However, connection with the common connections may result in a current loop, i.e. without additional measures a higher compensation current will flow between the bus participants and ground. Developers generally prevent this by decoupling the GND of the RS485 interface from the ground with a 100-Ohm resistor (image 11 c).

A better alternative is the galvanic separation of the RS485 interface from the supply voltage through an internal DC/DC converter and a signal isolator. This means that potential differences in the ground have no effect on the signal. The differential signal therefore "floats". Even better still is the galvanic separation of the RS485 interface in combination with a common connection.

Image 12 shows mixed operation between participants of galvanically separated and non-galvanically separated interfaces. The participants with the galvanically separated RS485 have no common connection in the example. In this case it is necessary to ensure that the common connections of the participants are connected with each other. Despite this, communication interferences can arise due to EMC coupling capacitors. This results in the non-galvanically separated participants no longer being able to interpret the signal. In this case the bus must be separated and an additional galvanic coupling must be integrated between the participant circuits.



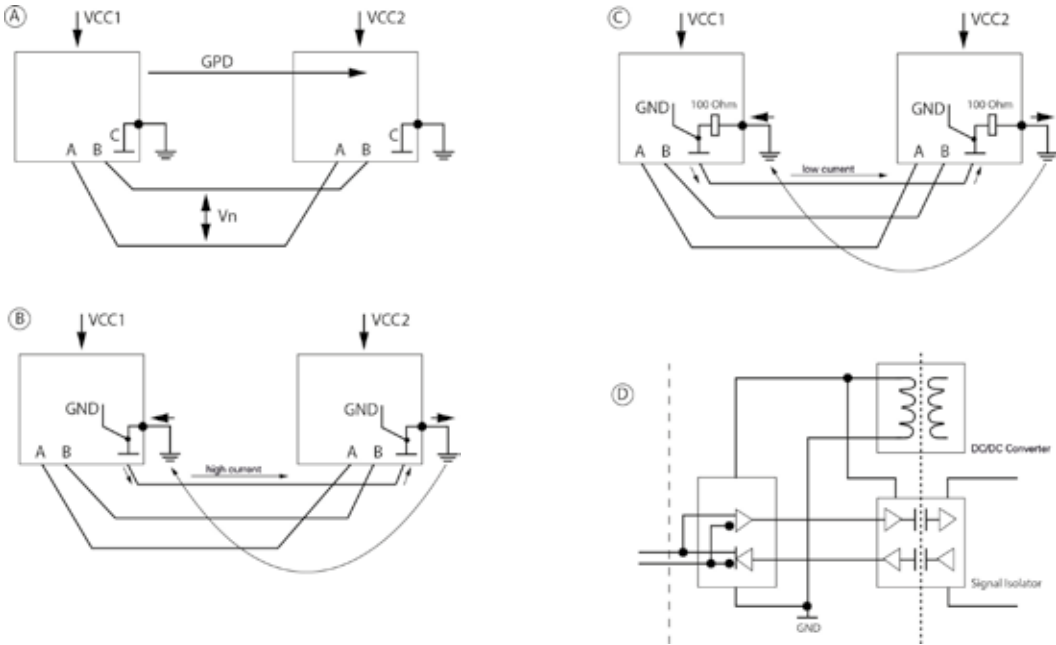


Fig.: Image 11

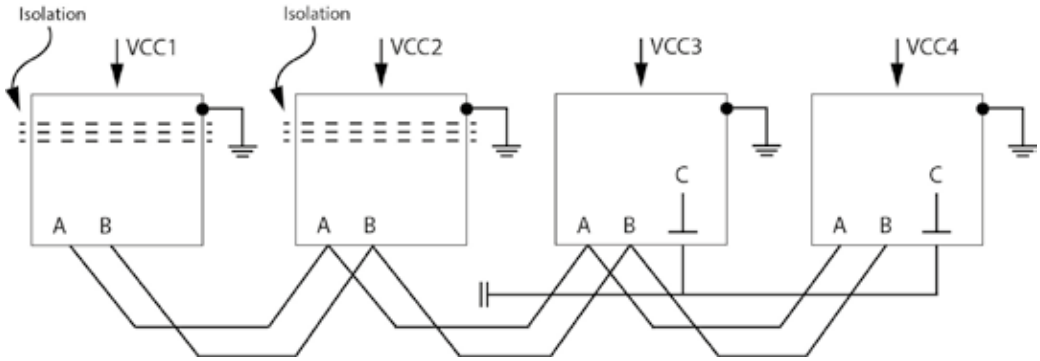


Fig.: Image 12

**Note:** The screening must never be connected to the common connection of the RS485 interface. This would result in faults being directly coupled with the GND of the RS485 transceiver.

# Analysis and optimisation of RS422 and RS485 bus systems

**Our recommendation: The MSB-RS485 Analyzer – For a perfect combination of hardware and software analysis**

Equipped with a variety of visualization tools, the analyzer allows a detailed look at each protocol layer in RS422/485 communications and detects errors caused by an incorrect data format, invalid timing, faulty bytes or telegram separations as well as incorrect telegrams and/or checksums. Its Interactive Real-Time Analysis capability makes it especially ideal in development, debugging, protocol parameter customization, and training (how protocols work, etc.).

- Up to 200 MHz sampling rate
- PC-independent time resolution of 10 nanoseconds for time-critical protocols and fast transmission
- Versatile due to ready-to-use protocol templates for 3964(R), Modbus, Profibus, DNP3, IEC60870 and many others
- Analysis of individual/proprietary protocols through custom protocol templates
- OSI layer-based visualization of signal levels (tri-state), raw data and telegrams
- Two decoding units that operate independently for simultaneous recording and analysis of two bus systems with different transmission characteristics
- Asynchronous transmission with arbitrary baud rates from 1...20 MBaud and 5-9 bit data lengths
- Variable connection types enable both the complete recording of all bus activities as well as the targeted recording of data sent by selected bus nodes
- Scriptable using combinable command line tools (e.g. for long-term recording and event triggering)



Available from [www.iftools.com](http://www.iftools.com)

## Ports, protocols and connections

UMG 604-PRO / UMG 605-PRO	
Protocols	Ports
TFTP	1201
Modbus /TCP – Modbus / UDP	502, 4 Ports
DHCP	68
NTP	123
BACnet	47808
Nameservice	1200
HTTP	80
FTP	21
FTP data port	1024, 1025
FTP data port	1026, 1027
Modbus over Ethernet	8000, 1 Port
Service port (telnet)	1239
SNMP	161 / 162 (TRAP)
E-Mail port (actual)	25
E-Mail port (in preparation)	587

GridVis®	
Protocols	Ports
Modbus /TCP – Modbus / UDP	502
HTTP	80
FTP	21
FTP data port	1024, 1025
FTP data port	1026, 1027
Modbus /TCP	502
Modbus over Ethernet	8000
Read out telnet data port	1239
Update telnet data port	1236, 1237
E-Mail port (in preparation)	25
E-Mail port (in preparation)	587

UMG 103-CBM	
Protocols	Ports
The devices do not have an Ethernet connection	The devices do not have an Ethernet connection

**Number of TCP/UTP connections (UMG 604-PRO / UMG 605-PRO)**

- A max. total of 24 connections are possible via the TCP group.  
The following applies:
  - Port 21 (FTP): max. 4 connections
  - Port 25/587 (E-Mail): max. 8 connections
  - Port 1024-1027 (data port to every FTP port): max. 4 connections
  - Port 80 (HTTP): max. 24 connections
  - Port 502 (ModbusTCP/IP): max. 4 connections
  - Port 1239 (Debug): max. 1 connection
  - Port 8000 (Modbus or TCP/IP): max. 1 connection
- Connection-free communication via the UTP group
  - Port 68 (DHCP)
  - Port 123 (NTP)
  - Port 161/162 (SNMP)
  - Port 1200 (Nameservice)
  - Port 1201 (TFTP)
  - Port 47808 (BACnet)

**The UMG 96RM-E supports the following protocols via Ethernet connection**

Client services	Ports
DNS	53 (UDP / TCP)
DHCP-Client (BootP)	68 (UDP)
NTP (Client)	123 (UDP)
E-Mail (sending)	Selectable (1-65535TCP)

Server services	Port
Ping	(ICMP / IP)
FTP	20 (TCP)*, 21 (TCP)
HTTP	80 (TCP)
NTP (only listen)	123 (UDP Broadcast)
SNMP	161 (UDP)
ModbusTCP	502 (UDP / TCP)
Device identification	1111 (UDP)
Telnet	1239 (TCP)
Modbus RTU (Ethernet encapsulated)	8000 (UDP)

\* Random port (> 1023) for data transfer, if work is taking place in PASSIVE mode

The UMG 96RM-E can administrate 20TCP connections.

Client services are contacted by a device on a server via the specified ports, the server services make the device available.

The following protocols are not supported.

BACnet (47808 / UDP)

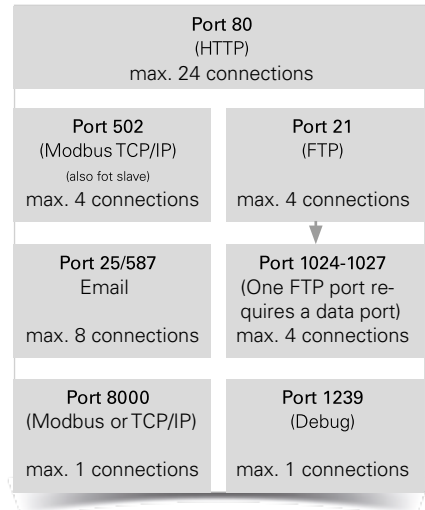


Fig.: TCP group: max. 24 connections (queue scheduling) (UMG 604-PRO / UMG 605-PRO)

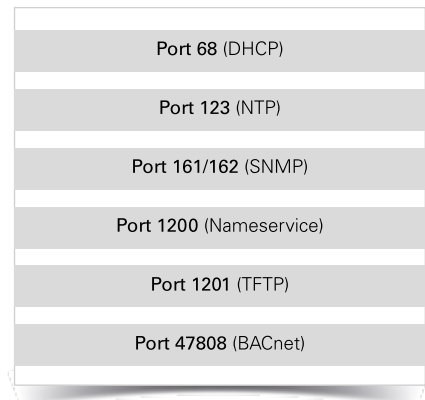


Fig.: UTP group: Connection-free communication (UMG 604-PRO / UMG 605-PRO)

# Basics for power factor correction

## Active power

If one connects an effective resistor, e.g. a heating device, in an alternating current circuit then the current and voltage are in phase. The momentary power values (P) are determined with alternating current through the multiplication of associated momentary values of current (I) and voltage (U). The course of the active power is always positive with doubled mains frequency.

The AC power has the peak value  $P = U \times I$ . Through area conversion it can be converted into the equivalent DC power, the so-called active power P. In the event of effective resistance, the active power is half the size of the peak power value.

In order to determine the AC power, one always calculates using the effective values.

$$P = U \cdot I$$

[W] [V] [A]

Fig.: Active power formula

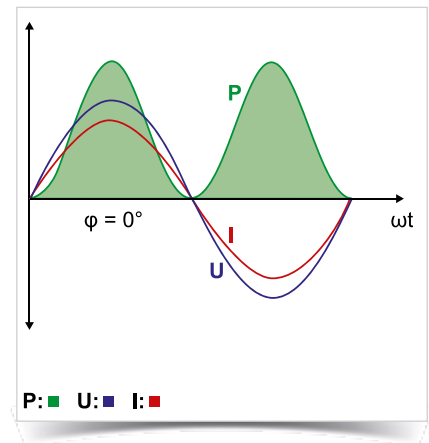


Fig.: AC power with purely ohmic load

## Active and reactive power

A purely ohmic load rarely arises in practice. An inductive component usually also arises. This applies to all loads, which require a magnetic field in order to function (e.g. motors, transformers, etc.). The current used, which is required in order to generate and reverse the polarity of the magnetic field, is not dissipated but flows back and forth as reactive current between the generator and the load.

Phase shifting arises, i.e. the zero point transitions for voltage and current are no longer congruent. With an inductive load the current follows the voltage, with a capacitive load the relationship is precisely the opposite. If one now calculates the momentary power values ( $P = U \times I$ ), negative values will always arise if one of the two factors is negative.

Example:

Phase shifting  $\varphi = 45^\circ$  (equates to an inductive  $\cos \varphi = 0.707$ ). The power curve overlaps in the negative range.

$$P = U \cdot I \cdot \cos \varphi$$

[W] [V] [A]

Fig.: Calculation of the effective power with ohmic and inductive load

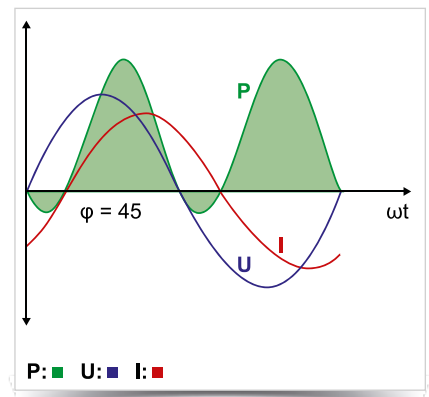


Fig.: Voltage, current and power with mixed ohmic, inductive load

### Reactive power

Inductive reactive power arises for example in motors and transformers – without consideration to line, iron and friction losses.

If the phase shifting between current and voltage is  $90^\circ$ , e.g. with "ideal" inductance or with capacity, then the positive and negative area portions are of equal size. The effective power is then equal to the factor 0 and only reactive power arises. The entire energy shifts back and forth here between load and generator.

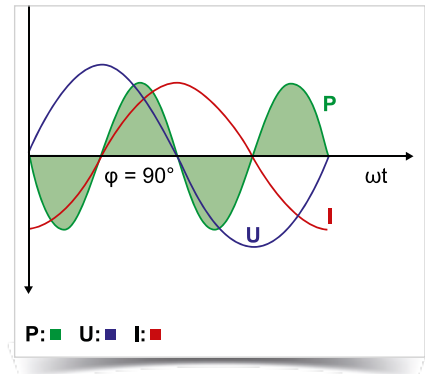


Fig.: Voltage, current and power with pure reactive load

$$Q = U \cdot I \cdot \sin \varphi$$

[var] [V] [A]

Fig.: Determination of the inductive reactive power

### Apparent power

The apparent power is the electrical power that is supplied to or is to be supplied to an electrical load. The apparent power  $S$  is derived from the effective values of current  $I$  and voltage  $U$ .

In the event of insignificant reactive power, e.g. with DC voltage, the apparent power is the same as the active power. Otherwise this is greater. Electrical operating equipment (transformers, switchgear, fuses, electrical lines, etc.), which transfer power, must be appropriately configured for the apparent power to be transferred.

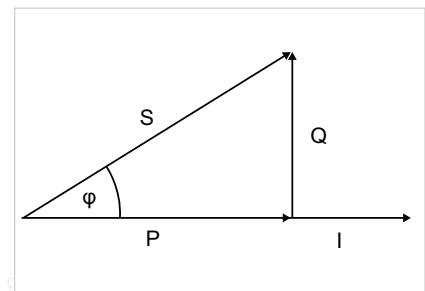


Fig.: Power diagram

$$S = U \cdot I$$

[VA] [V] [A]

Fig.: Apparent power without phase shifting

### Apparent power with sinusoidal variables

With sinusoidal variables the offset reactive power  $Q$  arises, if the phases of current and voltage are shifted by an angle  $\varphi$ .

$$S = \sqrt{P^2 + Q^2}$$

[VA] [W] [var]

Fig.: The apparent power is the result of the geometric addition of active and reactive power.

**Power factor (cos φ and tan φ)**

The relationship of active power P to apparent power S is referred to as the effective power factor or effective factor. The power factor can lie between 0 and 1.

With pure sinusoidal currents, the effective power factor concurs with the cosine (cos φ). It is defined from the relationship P/S. The effective power factor is a measure through which to determine what part of the apparent power is converted into effective power. With a constant effective power and constant voltage the apparent power and current are lower, the greater the active power factor cos φ.

The tangent (tan) of the phase shift angle (φ) facilitates a simple conversion of the reactive and effective unit.

$$\cos \varphi = \frac{P}{S} \quad [\text{W}] / [\text{VA}]$$

Fig.: Determination of the power factor over effective and apparent power

$$\tan \varphi = \frac{Q}{P} \quad [\text{var}] / [\text{W}]$$

Fig.: Calculation of the phase shifting over reactive and effective power

The cosine and tangent exist in the following relationship to each other:

$$\cos \varphi = \sqrt{\frac{1}{1 + \tan^2 \varphi}}$$

Fig.: Relationship to cos φ and tan φ

In power supply systems the highest possible power factor is desired, in order to avoid transfer losses. Ideally this is precisely 1, although in practical terms it is around 0.95 (inductive). Energy supply companies frequently stipulate a power factor of at least 0.9 for their customers. If this value is undercut then the reactive energy utilised is billed for separately. However, this is not relevant to private households. In order to increase the power factor, systems are used for power factor correction. If one connects the capacitor loads of a suitable size in parallel then the reactive power swings between the capacitor and the inductive load. The superordinate network is no longer additionally loaded. If, through the use of PFC, a power factor of 1 should be attained, only the effective current is still transferred.

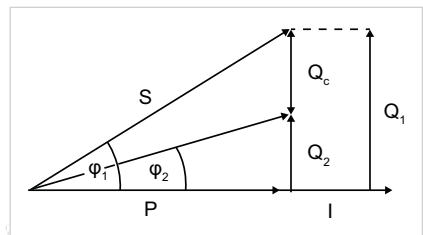


Fig.: Power diagram with application of power factor correction

The reactive power Qc, which is absorbed by the capacitor or dimensioned for this capacitor, results from the difference between the inductive reactive power Q1 before correction and Q2 after correction.

The following results:  $Q_c = Q_1 - Q_2$

$$Q_c = P \cdot (\tan \varphi_1 - \tan \varphi_2)$$

[var] [W]

Fig.: Calculation of the reactive power for the improvement of the power factor

## Calculation formula for the capacitor

### Capacitor output single-phase

Example: 66.5  $\mu\text{F}$  with 400 V / 50 Hz  
 $0.0000665 \cdot 400^2 \cdot 2 \cdot 3.14 \cdot 50 = 3,340 \text{ var} = 3.34 \text{ kvar}$

$$Q_c = C \cdot U^2 \cdot 2 \cdot \pi \cdot f_n$$

### Capacitor output with delta connection

Example: 3 x 57  $\mu\text{F}$  with 480 V / 50 Hz  
 $3 \cdot 0.000057 \cdot 480^2 \cdot 2 \cdot 3.14 \cdot 50 = 12,371 \text{ var} = 12.37 \text{ kvar}$

$$Q_c = 3 \cdot C \cdot U^2 \cdot 2 \cdot \pi \cdot f_n$$

### Capacitor output with star connection

Example: 3 x 33.2  $\mu\text{F}$  with 400 V / 50 Hz  
 $3 \cdot 0.0000332 \cdot (400 / 1.73)^2 \cdot 2 \cdot 3.14 \cdot 50 = 1670 \text{ var} = 1.67 \text{ kvar}$

$$Q_c = 3 \cdot C \cdot (U / \sqrt{3})^2 \cdot 2 \cdot \pi \cdot f_n$$

### Capacitor current in the phase conductor

Example: 25 kvar with 400 V  
 $25,000 / (400 \cdot 1.73) = 36 \text{ A}$

$$I = \frac{Q}{U \cdot \sqrt{3}}$$

$$Q_c = I \cdot U \cdot \sqrt{3}$$

### Series resonant frequency ( $f_r$ ) and de-tuning factor ( $p$ ) of de-tuned capacitors

Example:  $p = 0.07$  (7 % de-tuning) in the 50-Hz network

$$f_r = 50 \cdot \sqrt{\frac{1}{0.07}} = 189 \text{ Hz}$$

$$f_r = f_n \cdot \sqrt{\frac{1}{p}} \quad p = \left( \frac{f_n}{f_r} \right)^2$$

**Required nominal capacitor output three-phase in de-tuned configuration**

Example: 3 x 308 μF with 400 V / 50 Hz with p = 7 % de-tuned

$$0.000308 \cdot 3 \cdot 400^2 \cdot 2 \cdot 3.14 \cdot 50 / (1 - 0.07) = 50 \text{ kvar}$$

$$Q_c = \left(1 - \frac{7}{100}\right) \cdot \frac{440^2}{400^2} \cdot 50 = 56,3 \text{ kvar}$$

Which capacitor should be used for this?

This means, for a 50-kvar stage, a 440-V-56-kvar capacitor is required.

$$Q_c = \frac{C \cdot 3 \cdot U^2 \cdot 2 \cdot \pi \cdot f_n}{1 - p}$$

$$Q_c = \left(1 - \frac{P}{100}\right) \cdot \frac{U_c^2}{U_N^2} \cdot N_c$$

**Power factor and cos and tan conversion**

$$\cos \varphi = \frac{P}{S}$$

$$\cos \varphi = \sqrt{\frac{1}{1 + \tan^2 \varphi}}$$

**Conversion of the capacitor power subject of the mains voltage**

Determination of the reactive power  $Q_{new}$  · C is constant here.

**Example:**

Network: 400 V, 50 Hz, 3-phase

Nominal capacitor data: 480 V, 70 kvar, 60 Hz, 3-phase, delta, un-choked

Question: Resultant nominal capacitor power?

$$Q_{new} = \left(\frac{400}{480}\right)^2 \cdot \frac{50}{60} \cdot 70 = 40,5 \text{ kvar}$$

$$Q_{new} = \left(\frac{U_{new}}{U_C}\right)^2 \cdot \frac{f_{new}}{f_R} \cdot Q_C$$

The resultant correction power of this 480-V capacitor connected to a 400-V-50-Hz network is just 40.5 kvar.

**Definition**

- $Q_C$  Nominal capacitor power
- $P$  Degree of de-tuning
- $U_C$  Capacitor voltage
- $U_N$  Nominal voltage
- $N_C$  Effective filter output
- $Q_{new}$  New reactive power
- $U_{new}$  New voltage
- $f_{new}$  New frequency
- $f_R$  Nominal frequency of the capacitor



## Cable cross-section and fuses

With this table we provide general and non-binding information on standard practice. Connection cross-sections and the extent of protection are dependent not only on the nominal power of the PFC system but also on national regulations, the cable material used and the ambient conditions. The recommendation for the fuse current strength is for short circuit protection, HRC fuses are unsuitable for overload protection with power capacitors. The system installer or planning office are responsible for dimensioning and selecting the line cross-sections and fuses in individual cases.

PFC cable cross-sections, fuses (with networks with 400 V / 50 Hz)			
Output kvar	Rated current A	Cable cross-section NYY-J mm <sup>2</sup>	HRC fuse in A
5	7	4 x 2.5	16
7.5	10	4 x 4	20
10	14	4 x 4	25
12.5	18	4 x 6	35
15	22	4 x 6	35
17.5	25	4 x 10	50
20	29	4 x 10	50
25	36	4 x 16	63
30	43	4 x 16	80
37.5	54	4 x 25	100
50	72	3 x 35/16	125
55 – 65	79 – 94	3 x 35/16	160
70 – 85	101 – 123	3 x 70/35	200
86 – 100	124 – 145	3 x 95/50	250
101 – 125	146 – 181	3 x 120/70	250
126 – 160	182 – 231	2"3 x 70/35	315
161 – 180	233 – 260	2"3 x 95/50	400
181 – 200	261 – 289	2"3 x 120/70	400
201 – 250	290 – 361	2"3 x 150/70	500
251 – 300	362 – 434	2"3 x 185/95	630

Connection cross-sections only apply for the cited capacitor powers.

**Important information:**

When expanding existing systems, the busbar division must be carried out in advance!

Power factor correction systems with power of over 300 kvar have two separate busbar systems and require two separate feeds. The table applies to conventional and de-tuned PFC systems. It is always necessary to observe the most recent valid specifications (e.g. DIN VDE 0298).

# cos phi

## Calculation of the requisite kvar PFC power

This selection table has been generated for calculation of the requisite reactive power. You can determine a multiplier from the table using the actual power factor and the target power factor, and multiply this with the active power requiring correction. The result is the reactive power required for your power factor correction system. This calculation table can also be found as an MS Excel file on our homepage under <http://www.janitza.com/downloads/tools/kvar-table/>.

cos phi selection table												
										Active power ACTUAL cos φ TARGET cos φ Factor F from table Correction power		
										$P = 100 \text{ kW}$ $= 0.65$ $= 0.95$ $= 0.84$ $Q_c = P \times (\tan \phi_1 - \tan \phi_2)$ $P \times F$ $100 \times 0.84$ $84 \text{ kvar}$		
ACTUAL		Target power factor										
tan φ	cos φ	cos φ										
		0.80	0.82	0.85	0.88	0.90	0.92	0.94	0.95	0.96	0.98	1.00
Factor F												
1.33	0.60	0.58	0.64	0.71	0.79	0.85	0.91	0.97	1.00	1.04	1.13	1.33
1.30	0.61	0.55	0.60	0.68	0.76	0.81	0.87	0.94	0.97	1.01	1.10	1.30
1.27	0.62	0.52	0.57	0.65	0.73	0.78	0.84	0.90	0.94	0.97	1.06	1.27
1.23	0.63	0.48	0.53	0.61	0.69	0.75	0.81	0.87	0.90	0.94	1.03	1.23
1.20	0.64	0.45	0.50	0.58	0.66	0.72	0.77	0.84	0.87	0.91	1.00	1.20
1.17	0.65	0.42	0.47	0.55	0.63	0.68	0.74	0.81	0.84	0.88	0.97	1.17
1.14	0.66	0.39	0.44	0.52	0.60	0.65	0.71	0.78	0.81	0.85	0.94	1.14
1.11	0.67	0.36	0.41	0.49	0.57	0.62	0.68	0.75	0.78	0.82	0.90	1.11
1.08	0.68	0.33	0.38	0.46	0.54	0.59	0.65	0.72	0.75	0.79	0.88	1.08
1.05	0.69	0.30	0.35	0.43	0.51	0.56	0.62	0.69	0.72	0.76	0.85	1.05
1.02	0.70	0.27	0.32	0.40	0.48	0.54	0.59	0.66	0.69	0.73	0.82	1.02
0.99	0.71	0.24	0.29	0.37	0.45	0.51	0.57	0.63	0.66	0.70	0.79	0.99
0.96	0.72	0.21	0.27	0.34	0.42	0.48	0.54	0.60	0.64	0.67	0.76	0.96
0.94	0.73	0.19	0.24	0.32	0.40	0.45	0.51	0.57	0.61	0.64	0.73	0.94
0.91	0.74	0.16	0.21	0.29	0.37	0.42	0.48	0.55	0.58	0.62	0.71	0.91
0.88	0.75	0.13	0.18	0.26	0.34	0.40	0.46	0.52	0.55	0.59	0.68	0.88
0.86	0.76	0.11	0.16	0.24	0.32	0.37	0.43	0.49	0.53	0.56	0.65	0.86
0.83	0.77	0.08	0.13	0.21	0.29	0.34	0.40	0.47	0.50	0.54	0.63	0.83
0.80	0.78	0.05	0.10	0.18	0.26	0.32	0.38	0.44	0.47	0.51	0.60	0.80
0.78	0.79	0.03	0.08	0.16	0.24	0.29	0.35	0.41	0.45	0.48	0.57	0.78
0.75	0.80		0.05	0.13	0.21	0.27	0.32	0.39	0.42	0.46	0.55	0.75
0.72	0.81		0.03	0.10	0.18	0.24	0.30	0.36	0.40	0.43	0.52	0.72
0.70	0.82			0.08	0.16	0.21	0.27	0.34	0.37	0.41	0.49	0.70
0.67	0.83			0.05	0.13	0.19	0.25	0.31	0.34	0.38	0.47	0.67
0.65	0.84			0.03	0.11	0.16	0.22	0.28	0.32	0.35	0.44	0.65
0.62	0.85				0.08	0.14	0.19	0.26	0.29	0.33	0.42	0.62
0.59	0.86				0.05	0.11	0.17	0.23	0.26	0.30	0.39	0.59
0.57	0.87				0.03	0.08	0.14	0.20	0.24	0.28	0.36	0.57
0.54	0.88					0.06	0.11	0.18	0.21	0.25	0.34	0.54
0.51	0.89					0.03	0.09	0.15	0.18	0.22	0.31	0.51
0.48	0.90						0.06	0.12	0.16	0.19	0.28	0.48
0.46	0.91							0.03	0.09	0.13	0.25	0.46
0.43	0.92								0.06	0.10	0.22	0.43
0.40	0.93									0.03	0.10	0.40
0.36	0.94										0.07	0.36
0.33	0.95											0.33
0.29	0.96											0.29
0.25	0.97											0.25

## Fixed PFC

Selection table – fixed PFC of motors				
Motor power in kW	Capacitor power when idling in kvar (dependent on rpm)			
	3,000	1,500	1,000	750
1.5	0.8	1	1.1	1.2
3	1.5	1.6	1.8	2.3
5.5	2.2	2.4	2.7	3.2
7.5	3.4	3.6	4.1	4.6
11	5	5.5	6	7
15	6.5	7	8	9
18.5	8	9	10	11
22	10	11	12	13
30	14	15	17	20
45	19	21	24	28
75	28	32	37	41
90	34	39	44	49
110	40	46	52	58

Guideline values for the individual correction of motors per VDEW



**Comment:**

- Values only provide a guideline value
- It is essential to avoid overcorrection, in order to prevent overexcitation

Selection table – fixed PFC of transformers	
Nominal Transformer power in kVA	Nominal capacitor power in kvar
100	4.8
160	6.25
200	7.2
250	7.5
315	9.3
400	10
500	12.5
630	15
800	20
1,000	25
1,250	30
1,600	40
2,000	50



**Comment:**

- Values only provide a guideline value (with three-phase transformers with normal losses the PFC correction power is between 1 and 5 % of their nominal power depending on size)
- It is essential to observe regional energy supplier specifications.
- Ensure the appropriate back-up fuses and short circuit-proof lines

# Protection classes per EN 60529

## Protection of electrical operating equipment

Electrical operating equipment (e.g. lights, LED modules and operating devices) must belong to a certain protection class per EN 60529 according to their loading by foreign bodies and water. The protection classes are also referred to as IP codes. The abbreviation IP stands for "International Protection" or "Ingress Protection".

### The IP code per EN 60529

The protection class afforded by a housing is verified according to standardised test procedures. The IP code is used in order to classify this protection class. This comprises the two letters IP and a two-digit characteristic number. The protection classes refer exclusively to the protection against contact and the penetration of solid foreign bodies and dust (indicated by the first characteristic number of the IP code), as well as the harmful penetration of water (indicated by the second characteristic number of the IP code). The protection classes do not provide any information regarding the protection against external influences. Furthermore, the protection classes must not be confused with the electrical protection classes, which refer to the protective measures for the prevention of an electric shock.

**Important information: In addition to the protection class it is also always necessary to take into consideration the external influences and conditions.**

Code letters	
IP	International Protection (Ingress Protection)

Characteristic number 1	Protection against foreign bodies	Protection against contact
0	No protection	No protection
1	Protected against solid foreign bodies with a diameter from 50 mm	Protected against access with the back of the hand
2	Protected against solid foreign bodies with a diameter from 12.5 mm	Protected against access with a finger
3	Protected against solid foreign bodies with a diameter from 2.5 mm	Protected against access with a tool
4	Protected against solid foreign bodies with a diameter from 1.0 mm	Protected against access with a wire
5	Protected against dust in harmful quantities	Full protection against contact
6	Dust-tight	Full protection against contact

Characteristic number 2	Protection against water
0	No protection
1	Protection against drops of water falling vertically
2	Protection against drops of water falling, if the housing is tilted up to 15°
3	Protection against sprayed water falling, up to 60° from vertical
4	Protection against splash water on all sides
5	Protection against water jets (nozzle) from any angle
6	Protection against powerful water jets
7	Protection against intermittent submersion
8	Protection against continuous submersion

# Prerequisite and confirmation for commissioning (VBI)

## General information

The prerequisite and confirmation for commissioning (VBI) is used for the preparation and advance information for commissioning by Janitza electronics GmbH. The confirmation for correct electrical installation as well as the technical prerequisite for the installation of the software is needed prior to commissioning.

## General information on the electrical installation of the Janitza measurement devices

- **Access:** All devices are fully functional (auxiliary voltage, connection, etc.) and freely accessible for interface, connection and display.
- **Interfaces:** The bus connection between the devices and to the PC is correctly wired and functional. Information on the connection of the interfaces and wiring can be found in the associated operating instructions.
- **Wiring:** A stub has not been formed on the RS485 interface (see graphic). This means all devices have been connected in series to the power analyser.
- **Bus cable:** A bus cable has been used for the wiring of the RS485. The cable must be shielded and the wires (A&B) must be twisted with one another. We recommend the following bus cable: Li2YCY(TP)2x2x0.22).
- **Master:** The following structure has been adhered to in the bus lines:  
The Master (UMG 604-PRO / UMG 605-PRO / UMG 96RM-E) is the first participant on the bus.
- **RS485:** With UMG 604-EP, UMG 605-PRO, UMG 96RM-P, UMG 509-PRO und UMG 512-PRO the requisite Profibus connector has been used for the RS485 interface. The Profibus connector is essential as the RS485 interface is connected to the termination resistor.
- **Set-up plan:** A set-up plan of the bus connection of all bus-participants has been transferred beforehand per e-mail/fax to the responsible technician (support@janitza.com).
- **Current transformer setting:** The current transformer settings are implemented by the customer. If the setting of the transformer is part of the commissioning (see specification sheet), a device list with name-related CT data must be transferred in advance to the responsible technician.

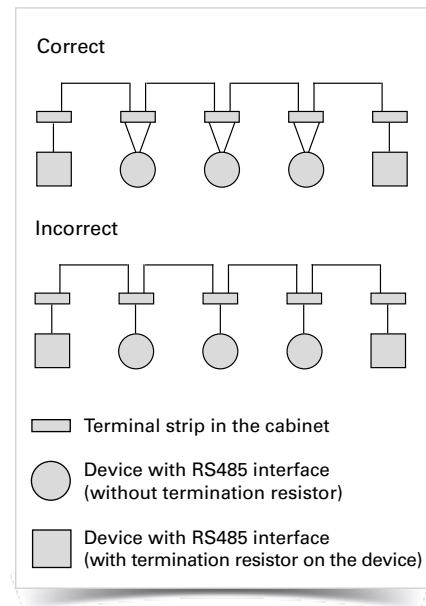


Fig.: Modbus configuration

- **IP addresses:** The device names and IP addresses must be defined, documented and communicated to the responsible technician prior to the commissioning.
- **Settings:** For measurement devices with an Ethernet connection, the IP addresses must be assigned. If the setting of the IP address is part of the commissioning (see specification sheet), a device list with IP address, subnet mask and gateway must be given in advance to the responsible technician.
- **Termination resistor:** A termination resistor of 120 Ohm must be placed at the beginning and end of a bus line between A and B. Devices with Profibus connectors are switched to ON.
- **Connection:** After connecting the measurement devices, the following measurement values must be checked:
  - The effective power of the individual phases should be positive. If this is not the case, there is a power feedback or a wrong CT connection (k and l miswired).
  - The cos phi of the individual phases should be above a realistic value of 0.5 (reference value). If this is not the case, the phase assignments of the current and voltage measurement must be checked. The current and voltage connection must be assigned correctly to the phases.
- **Database:** The database MySQL / MS SQL is installed and administrated.

**For the commissioning, it is important that a local responsible electrician / installer is present on site during the commissioning.**

## Software installation and network administration

The following points show the prerequisite and properties of the GridVis® Power Grid Monitoring Software (status vers. 4) from Janitza electronics GmbH.

- **GridVis® licence:** In order to activate GridVis® an account is required on the Janitza ID server (<https://id.janitza.de>). The account should be created prior to commissioning by the person responsible. For the Standard and Expert editions an activation code is required. The activation code can be purchased from the Janitza electronics GmbH. Internet access is required for the activation.

- **PC system prerequisites:**

- Up-to-date processor architecture: recommended Intel Xeon (server compatible)
- RAM: Min. 8 GB (standard database)  
Recommended: 16 GB (MySQL-, MSSQL database)
- Installing storage space: 2 GB
- 64 Bit system
- Recommended and optimized screen resolution: 1280 x 960 Pixel

- **Supported web browsers**

- Google Chrome (current version) - *recommended*
- Microsoft Edge
- Firefox (current version)

- **Supported operating systems:**

- Microsoft Windows Server 2008
- Microsoft Windows Server 2012
- Microsoft Windows Server 2016
- Microsoft Windows Server 2019
- Microsoft Windows 8
- Microsoft Windows 10
- Linux distributions on request and only for large projects

- **Memory reserves:** The memory capacity required for archiving the data depends on the number of measurement devices. Approx. 500 MB memory per year can be assumed for one measurement device. (Number of devices times 500 MB times the years of archiving).

- **GridVis®-Basic:** GridVis®-Basic is supplied with the Janitza database as standard.

- The installation / administration of the database MySQL / MS SQL is not a component of commissioning. The following data must be provided to the individual who commissions the system:

- IP database
- Port number
- Name of the database
- User and password

• **GridVis® license model / software variants:**

	<b>GridVis® Essentials</b>	<b>GridVis® Standard</b>	<b>GridVis® Expert</b>
<b>SYSTEM FUNCTIONS</b>			
Device configuration	•	•	•
Service	–	•	•
Logic	–	•	•
Automation	–	•	•
Database management	–	•	•
Device monitoring	–	•	•
User management	–	•	•
Active directory	–	–	•
Alarm management	–	–	•
Online recorder	–	–	•
<b>VISUALIZATION</b>			
Graph function	•	•	•
Device overview	•	•	•
Event browser	•	•	•
Dashboards & templates	–	•	•
Widget basic package	–	•	•
Widget enhancement	–	–	•
Sankey diagram	–	–	•
Key performance indicators (KPI)	–	–	•
<b>DOCUMENTATION</b>			
Basic data exports	•	•	•
RCM data exports	•	•	•
PQ data exports	–	•	•
EnMS data exports	–	•	•
<b>CONNECTIVITY</b>			
CSV data import	–	•	•
MSCONS data import	–	•	•
Modbus devices from third party suppliers	–	–	•
OPC UA Client	–	–	•
REST API	–	–	•
Comtrade data exports	–	–	•
MSCONS data export	–	–	•

Further information on the GridVis® editions is available at:  
<https://www.gridvis.com/gridvis-editions.html>





• **Databases:**

- MSSQL - *recommended*:  
MSSQL 2014, 2016, 2017 and 2019 are supported.  
Express versions are not supported!
- MySQL (5.7.22 & 8.0.16)
- JanDB – included in the scope of delivery

• **Database information:**

- The database users require write and read rights.
- The database structure is generated by GridVis® when the project is created
- Ownership rights are required to create a project
- The "root" or "SA" root should not be used for GridVis® projects
- The database structure is open and documented

• **Standard database:**

The standard Janitza DB database can only be used locally; multiple access is only possible locally (e.g. GridVis® service in the background and GridVis® Desktop on the same computer/server).

• **Installation directories:**

The installation directory can be freely selected. If several users require access, the installation and the project must be in one directory area where access rights are granted to all users.

• **Project directory:**

The project directory may only be located locally on the computer/server. It is not possible to store the project directory on a network drive.

• **Port information:**

The following communication ports are required for the transfer of data between the measurement device and the software:

- HTTP 80
- FTP command port 21, (data port 1024, 1025, 1026, 1027)
- Modbus/TCP 502 (4 ports)
- NTP 123

The following communication ports can also be used:

- SNMP 161
- BaCnet 47808

• **Automatic memory readout:**

Starting with GridVis® Standard, the GridVis® software has an automatic read-out function that can be activated (installation of the GridVis® service).

• **GridVis®-Service information:**

- From the GridVis® Standard edition, service instances can be installed.
- Automatic memory reading from the edition GridVis® Standard and online reading from the edition GridVis® Expert are taken over by the Service in the background.
- One Service instance supports the management of 300 measurement devices.
- The web server port of the service instance can be changed during the installation.
- Service is managed by Windows and does not need a user login. When a restart is carried out, the Service is restarted.

• **Online reading:**

The GridVis® Power Grid Monitoring Software provides a possibility for recording and archiving measurement values online. This function can be used for measurement devices without ring buffer (memory), for example. The polling time is adjustable. Online reading is available from the edition GridVis® Expert.

• **Server-Client principle:**

Multiple access to a database depends on the database type. The Janitza database only supports local access. MySQL and MS SQL databases support multiple accesses. The read and write right must, however, be assigned a GridVis® Desktop instance or a GridVis® Service instance.

• **NTP – time synchronisation:**

Some Ethernet measurement devices have an NTP client for time synchronization. These measurement devices support the following modes:

- Active (IP is addressed directly)
- Listen (broadcast)

Time synchronisation without an NTP server can take place from GridVis®-Standard edition using the computer time.

• **Historical evaluation:**

Devices with ring buffer (memory) are required for a historical evaluation (period evaluation). An alternative is the GridVis® Expert edition, online recording for archiving can be used here.

**Administrative rights are needed for the installation during commissioning. Internet access should be available for the GridVis® activation. It is advisable to have a responsible person from the on-site IT department present during the commissioning to answer any questions directly.**

### Special instructions for the electrical installation of the Janitza measurement devices

If commissioning includes the ProData® 2 (consumption pulse recording), the following points must be noted:

- **ProData® 2 special instruction®:**

The pulse values for the ProData® 2 (consumption data recording of water/heat amounts, etc.) must be known before commissioning and must also be sent in advance to the responsible technician per e-mail.

Example: ProData® 2

Digital input 1 = auxiliary building water meter = 1 m<sup>3</sup> per pulse

Digital input 2 = main building heat meter = 1 kWh per pulse

etc.

### Instruction

After commissioning, the operating personnel should be given instruction on the GridVis® evaluation and configuration software. The instruction should be given on the configured computer with access to all measurement points. The instruction includes the following topics:

- Software navigation
- Configuration of the measurement devices
- Evaluation of the historical data (graph, reports)
- Creation of the topology
- Administration of automatic reading / time setting

### Contents of the commissioning (specification sheet)

The commissioning tasks are clearly defined. Tasks which are not part of the standard commissioning must also be recorded in the order. The number of measurement points to be integrated as well as the number of software instances to be installed must be defined before commissioning.

- Number of measurement points
- Number of GridVis®-Desktop instances
- Number of GridVis®-Service instances

**Tasks of standard commissioning:**

• **Installation:**

Installing the latest GridVis® Power Grid Monitoring Software (creating a project, importing a project)

• **Configuration:**

- Integration of all Janitza measurement points in the GridVis® Power Grid Monitoring Software (connection configuration)
- Configuring the device-specific application (pulse outputs, alarm outputs)
- Configuring automatic reading / online reading
- Software / Firmware update

• **Instruction on the GridVis® Power Grid Monitoring Software:**

- Device management
- Graph function
- Topology generation

**Additional commissioning performance:**

• **Configuration:**

- Implement all transformer settings
- Assign device addresses and IP addresses

• **Configuration:**

- Create customer-specific topology
- Integrate customer-specific Jasic® program
- Fault-finding, support
- Creation of virtual measurement points

**It is advisable to have the responsible local electrician / installer present during commissioning, in order to answer any questions directly. It would also be desirable if the operator of the system were present to receive instruction. To ensure the smooth running of the commissioning, all points should be completed.**

## Uptime through 3-in-1-Monitoring

Highly automated production systems, computer centres and systems with constant processes (e.g. food sector, cable fabrication, paper production) require a reliable power supply - often even uptime, i.e. an availability of at least 99.9%. The numerous servers, monitors, storage media and network components rarely tolerate voltage dips or other deviations in power quality from the standard (e.g. EN 50160). However, electrical energy does not only need to be reliably available for information and communication technology; this is also the case with infrastructure tasks such as air-conditioning, fire prevention, EMC, safety engineering, lighting, lifts and drives.

### 3-in-1 monitoring for safety and efficiency

It is no wonder, with all of these applications, that the demand for a safe power supply comes even before the ubiquitous energy efficiency. Constant monitoring with corresponding integrated measuring equipment for energy management, power quality and residual current monitoring fulfils this requirement; indeed it serves both purposes. At the same time, residual current monitoring also improves preventative fire protection. However, in practice it is highly complex to acquire, evaluate and document all of the measurement data. All of this must take place extremely quickly, e.g. if one wishes to detect an insulation fault that has just arisen before a system failure occurs.

Janitza - the specialist when it comes to digital measuring technology and monitoring systems in energy supply - has specially developed its new UMG 512-PRO, UMG 96RM-E and UMG 20CM ranges here, for monitoring over 3 levels (see section „Monitoring solutions in practice“). Together with the GridVis® Power Grid Monitoring Software and the integrated alarm management, solutions for three areas are united within a common system environment and just one measuring device per measurement point:

#### 3-in-1 monitoring

- Energy management according to ISO 50001 (acquisition of V, A, Hz, kWh, kW, kVArh, kvar ...)
- Power quality monitoring (harmonics, flicker, voltage dips, transients, etc.)
- Residual current monitoring (in short RCM)

This consolidation of the three different functions within a single measuring device brings with it the major advantage that both the assembly and installation, as well as the remaining infrastructure (current transformer, communication lines and equipment, database, software, analysis tools and reporting software, etc.) are only required once. Furthermore, all data is logged centrally in a database and can be conveniently processed with a single software. This not only saves direct costs during purchasing but also simplifies integration: No interfaces are required between the various systems – because there is just one system. This also reduces the scope of training measures and induction required, which in turn increases the acceptance amongst the electrical engineers responsible.

### Signal before failure

A significant advantage of this integrated data acquisition is its speed and the comprehensive overview of all data. This facilitates the detection of faults, which would only be partially perceived – or even entirely missed – by a single system. The user is therefore able to react before fuses or residual current devices (RCD) switch off affected systems or socket power circuits. This applies in particular to quietly rising residual currents (e.g. triggered by an insulation fault), overly high operating currents and any other overloading of system parts and loads (image 1).

Other sources of faults are massive grid feedback effects or resonance effects due to a growing number of non-linear electrical loads. If one detects irregular grid parameters such as excessively high harmonics or residual currents in a timely manner, it is still possible to commission repair measures before a device fails and in doing so avoid downtimes, or at least plan for these and reduce them.

### Universal tool RCM: Increased safety, increased system availability, reduced risk of fire

As previously mentioned, RCM is playing an increasingly important role with uptime power supplies, which are now found in almost all market segments. Constant processes and especially sensitive applications such as computer centres, hospitals and semiconductor factories are depending on RCM in particular. Furthermore, RCM measurement offers a good alternative in all areas in which it is not possible to utilise insulation resistance measurements and residual current devices due to local or operational circumstances. The „foresighted“ monitoring described also helps to reduce alarms, as required for example with alarm management according to EEMUA 191 or NAMUR NA 102.

However, RCM can do even more - namely reduce the risk of fire! Residual current, triggered by defective insulation, can be treacherous. The current level is determined by the power of the supply network, the insulation fault resistance and the resistance to ground. With a sufficiently high current flow (with a dead earth short or corresponding low-resistance short) the upstream protective device disconnects the electrical consumers from the

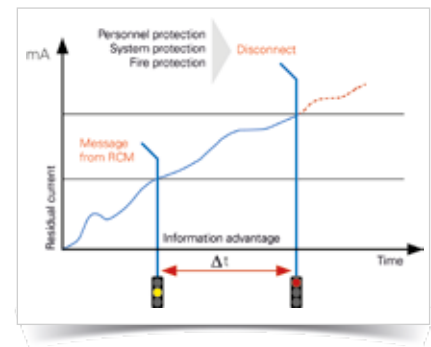


Fig. 1: Report prior to switching off - an aim of residual current monitoring (RCM)

mains. However, if the residual current is too low then the protective device will not trigger. If the recorded fault power exceeds a value of approx. 60 Watt (approx. 261 mA at 230 V), a risk of fire exists. Residual current monitoring therefore also serves as fire prevention. The next section explains how RCM works in detail.

### RCM – the functionality

The basic functionality of the residual current principle is shown in image 2. Here, the phase and neutral conductor of the protected output are fed through the summation current transformer, the ground wire is left out. The image provides a better overview due to the highly simplified wiring. In practical terms, all three phases and the neutral conductor run through the summation current transformer. If the system is in fault-free condition, the summation current is zero or close to zero (within a tolerable range), meaning that the current induced in the secondary circuit is also zero or close to zero. If, however, residual current flows away to ground due to a fault, the current differential in the secondary circuit will result in a current being logged and evaluated by the RCM measuring device (image 3).

Modern RCM devices accept different threshold value settings here (image 4). A static threshold value has the disadvantage that it is either too high with a part load, or too low with a full load, i.e. either insufficient protection is provided or erroneous alarms are issued, which may have negative effects on the attentiveness of the monitoring personnel over time. For this reason it is advisable to use RCM measuring devices with dynamic threshold value formation. In this case the residual current threshold value is formed on the basis of the actual load conditions and is therefore optimally aligned with the respective applicable load (image 5).

Through parameterisation (i.e. stipulation of the typical residual current in „GOOD“ condition) of the system in new condition and constant monitoring, all changes to the system state after the point of start-up can be detected. This also enables detection of creeping residual currents

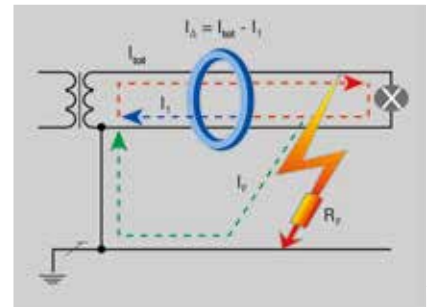


Fig. 2: Principle of residual current monitoring

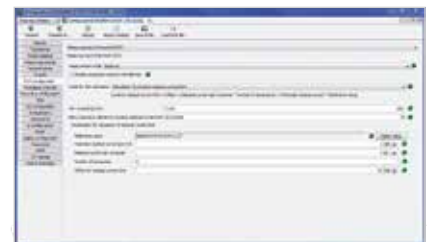


Fig. 4: (Comprehensive configuration options for RCM threshold value formation (e.g. dynamic threshold value formation) in the Power Grid Monitoring Software GridVis®)

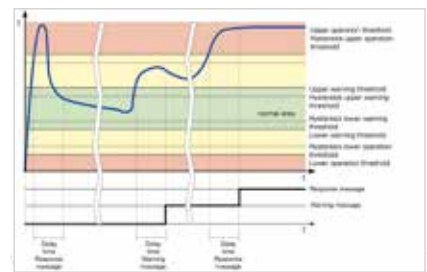


Fig. 5: Parameters of residual and operating current monitoring

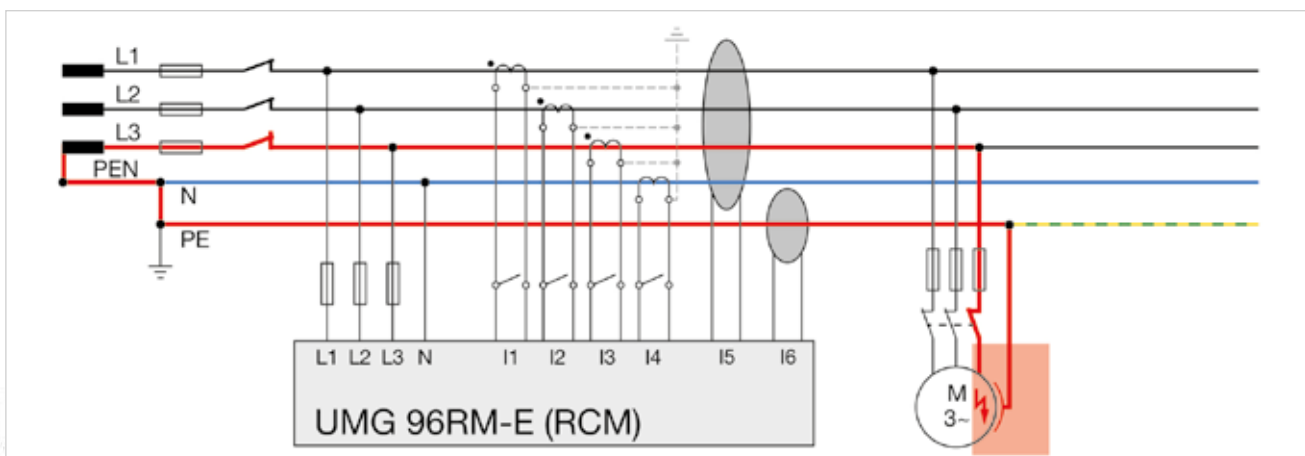


Fig. 3: Defective motor insulation leads to a short circuit to ground and residual current against the PE phase.

**New technology, new fault sources**

Examples of „modern fault sources“ include collapsing polypropylene PFC capacitors. These serve to compensate for reactive currents, which can be generated for example with three-phase motors. Paradoxically, a fault therefore arises due to equipment that is actually intended to improve the energy supply. With these capacitors, an overload or excessively high temperature frequently results in a melting of the PP winding. The melt in turn causes a high-resistance short circuit to ground. It is not possible to shut off such short circuits to ground with conventional protection measures (HRC fuse, circuit breaker). The constant residual current usually leads in the mid-term to a dead earth short circuit and may pose a considerable risk of fire or endanger safety under certain circumstances (image 6). The residual current measurement detects such faults and enables rapid countermeasures. In this way it is possible to avoid costly and dangerous system failures.

Errors such as impermissible connections between the N and PE phase also frequently arise during installation. The two are sometimes simply interchanged. Image 7 shows a typical connection error, which can easily result in a residual current of 5000 mA. With RCM, such errors are detected immediately during the installation phase and are reported via the alarm management.

A further and rather more recent fault source is a large number of single-phase loads, such as switched mode power supplies from servers in computer centres or PCs in office buildings. These generate a high proportion of 3rd harmonics. These harmonic portions bring with them the significant disadvantage that they superimpose themselves on the neutral conductor rather than being nullified via the transformer windings. This can result in overloads on the N phase. Integrated measuring devices, such as the UMG 96RM-E, enable comprehensive monitoring of all phases and are therefore able to report increased neutral conductor currents in a timely manner.

In this context, reference is also made to the safety specifications of the VdS (association of insurers in Germany) for electrical systems up to 1000 Volt:

„VdS 2046 : 2010-06 (11)

3.2.4 In order to increase the safety of electrical systems in which numerous non-linear loads (such as frequency converters, phase angle-controls e.g. in lighting systems) are operated, measurement of the current in the neutral conductor should take place regularly - e.g. once annually and additionally after any significant changes to the electrical system or the type and quantity of electrical loads. If the safety of the system is at risk due to excessively high harmonic currents, measures must be implemented in order to protect the harmonics according to the publication „Low-fault electrical installations“ (VdS 2349).“



Fig. 6: Destroyed PP reactive power compensation capacitor: A creeping high-resistance short circuit to ground has caused a complete melting of the capacitor and a local fire



Fig. 7: The N and PE have been interchanged here



### Challenge of uptime

IT technology itself places high demands on the supply. However, particularly critical are applications in which the loss of data simply cannot be allowed to occur. BITKOM therefore writes the following in its guidelines for „Operationally reliable computer centres“: „In computer centres the maximum availability requirements apply. The energy supply must therefore be permanently guaranteed. Therefore comprehensible is the requirement that the power supply to the computer centre itself, and to all areas in the same building to which data cables run, must be designed as a TN-S system. Essential for assured operation is permanent self-monitoring of a “clean” TN-S system and the issuance of signals to a permanently manned desk, e.g. in the control centre. The electrical engineer will then detect any action requirements on the basis of signals received, and can avoid damages through targeted service measures.“

With the Janitza solution, the safety criteria „RCM residual current monitoring“ can be realised through this type of EMC-optimised TN-S system (image 8).

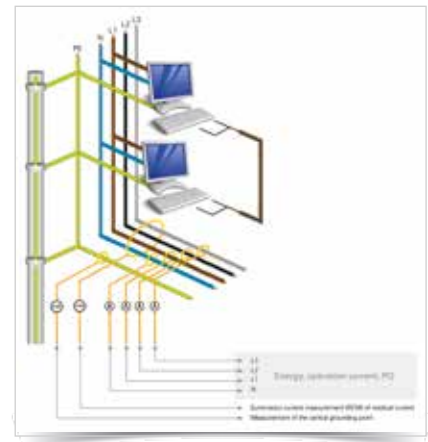


Fig. 8: Constant 3-in-1 monitoring (EnMs-RCM-PQ) of an EMC-optimised TN-S system

### Reduced testing costs with RCM

Recurrent testing, as prescribed for example in BGV A3 – Electrical systems and operating equipment, is time-intensive and therefore costly. RCM monitoring systems can reduce these test costs, whilst also ensuring increased safety. Fixed electrical systems and operating equipment are considered to be monitored constantly if they are permanently maintained by electrical engineers and tested by measuring equipment within the framework of operations (e.g. monitoring of the insulation resistance). Through permanent RCM measurement, monitoring systems are able to deliver the required degree of constant testing.

Particularly noteworthy here is that RCM renders the cost-intensive measurement of insulation resistances at least partially superfluous, whilst constant testing of the insulation characteristics takes place. In order to carry out conventional insulation measurements, fixed systems or loads must be switched off and the neutral conductor disconnected. Furthermore, there is a risk that the high test voltage used for the insulation measurement may damage sensitive electronic components. The test accuracy and scope can be reduced by constant monitoring. However, this must be determined on an application-specific basis. Discussions with the operator and if necessary also with experts and / or the employers’ liability insurance association are essential here!

It is also explicitly noted at this point that the following work must be carried out despite constant RCM measurement:

- Visual inspection for externally visible defects
- Protective measures and switch-off conditions
- Loop resistances and testing of the continuity of ground wires
- Functional testing

### The association of insurers (Germany) requires RCM

The VdS has said the following on the subject of harmonics / the installation of power supply systems:

„In the case of power supply systems with PEN phase, operational currents – which may cause damage – flow through the entire ground and potential equalisation system (see section 3.3). With new electrical system installations it is therefore necessary to plan TN systems as TN-S systems. In the case of existing TN-C systems, modification to a TS-S system is advised. TN-S systems must be realised from the supply (handover) point where possible.

In order to guarantee the functionality of a TN-S system on a permanent basis (no conductor short between the N and PE phase, interchanging of the N and PE phase) this must be monitored by a residual current measurement device (RCM).

If the set trigger value is reached, a perceivable optical and acoustic error signal must be issued, in order that the defect can be eliminated immediately. In order that signal issuance is successful, this should be sent to a manned desk where applicable. If signalling is dispensed with then the forced shut-down of the faulty current circuit is required...“

Elsewhere, with respect to the safety regulations for electrical systems up to 1000 Volt, the VdS prescribes:

„VdS 2046 : 2010-06 (11)

#### 3.2 Compliance with proper condition

3.2.3 In order to guarantee safety in electrical systems on a permanent basis, if it is not possible to carry out insulation resistance measurements due to local or operational circumstances then it is necessary to implement substitute measures. Such measures are described in the publication „Protection with insulation faults“ (VdS 2349).

An adequate substitute measure here is permanent RCM monitoring!

### Energy measurement and electrical standard parameters

RCM plays a dominant role in system monitoring by the Janitza system. Despite this, the following additional points should not go unmentioned: In addition to a safe energy supply, energy efficiency is playing an increasingly significant role. A milestone was set in place here with the implementation of the ISO 50001 standard. ISO 50001 is the standardised basis for the introduction of an energy management system - whereby the focus here lies on the term management system. This is a methodology, applied in conjunction with other management systems such as ISO 9001 or ISO 14001, through which to set objectives, implement these systematically and in doing so eliminate the chance factor insofar as possible. The term „objective“ should essentially be understood here in the sense of „the route is the objective“. As an example, the following is a quote from the resolution of the IT representatives council from February 2013:

(Page 2, Resolution No. 2013/2, Point 2)



Fig. 9: The „3-in-1“ measuring device from Janitza: UMG 512-PRO

„The IT council shall continue to strive towards a high proportion of constant measurements by the end of 2013 and asks the division to continue promoting the use of permanent measuring devices with consideration to the principle of cost efficiency.“ With all of its UMG measuring devices and electricity meters, Janitza offers the possibility of capturing and recording standard electrical parameters, as well as power and energy consumptions (image 9).

### Monitoring the power quality

RCM, as well as the requirements of Bitkom and the association of insurers, were dealt with in the first two parts. The final point of 3-in-1 monitoring is the power quality. The reliable operation of modern plants and systems always demands a high degree of supply reliability and good power quality. However, in modern energy supply a wide range of single and three-phase, non-linear loads are used in industrial networks right through to office blocks. These include lighting equipment such as lighting controls for headlamps or low energy bulbs, numerous frequency converters for heating, air-conditioning and ventilation systems, frequency converters for automation technology or lifts, as well as the entire IT infrastructure with the typically used regulated switched mode power supplies.

Today, one also commonly finds inverters for photovoltaic systems (PV) and uninterruptible power supplies (UPS).

All of these non-linear electrical loads cause grid feedback effects to a greater or lesser extent with a distortion of the original „clean“ sinusoidal form. This results in the current or voltage waveform being distorted in the same way (image 10 and image 11).

The load on the network infrastructure through the described electrical and electronic loads with grid feedback effects has increased significantly in recent years. Depending on the type of generation system and the operating equipment (mains feed with converter, generator), mains rigidity at the connection point and the relative size of the non-linear loads, varying grid feedback effects and influences arise. For safeguarded power supplies in computer centres, the power quality must reflect EN 61000-2-4 (Class 1).

With its broad palette of UMG measuring devices, Janitza offers the option of capturing and analysing the various parameters of power quality. Standardised power quality reports in the GridVis® Power Grid Monitoring Software (e.g. for EN 50160, EN 61000-2-4 and ITIC: „CBEMA Curve“) facilitate report generation for conventional standards at the touch of a button.

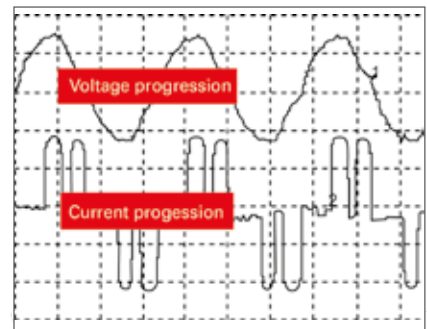


Fig. 10: Grid feedback effects through frequency converters

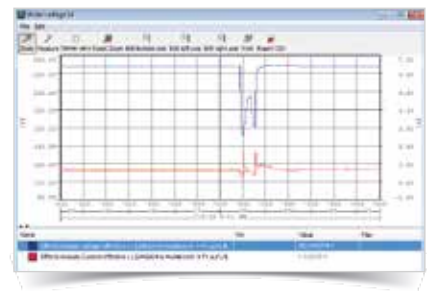


Fig. 11: Critical voltage dip with production standstill

### **Monitoring solutions in practice**

The aim of 3-in-1 monitoring solutions – the integrated measurement of energy, power quality and RCM – requires the measurement of all phases (L1, L2, L3, N) + CEP (central earth point) + RCM with a single measuring device. A high performance measuring device with 6 measuring current inputs for the 3-in-1 measurement is the UMG 96RM-E for intermediate distributors, or the UMG 512-PRO for main nodes and CEP from Janitza. The IP-based measuring devices can be easily integrated into existing communication networks via Ethernet. Numerous IP protocols, on-board homepage and SNMP protocol simplify the work of administrators.

The 20-channel UMG 20CM is ideal for complex electrical installations with a large number of monitoring points. The measuring devices are able to acquire (in arbitrary combinations), constantly log and analyse residual, earth leakage and operating currents via the associated measuring current transformers (e.g. CT-6-20).

Special residual current transformers in practical special designs are also suitable for cost-efficient retrofitting to existing systems, without the need to switch off electrical consumers.

### **Alarm in the right place**

Alarms must never sound unheard. An acoustic signal from the switch cabinet in the main distribution is of little use in the control room.

Through the integration of the RCM measuring devices in the GridVis® Power Grid Monitoring Software, with its comprehensive alarm management signalling options, it is possible to ensure that the signal quickly reaches the right recipient. With arbitrary escalation levels and logbook function, the monitoring control room has access to all the tools required for efficient monitoring. In this way it is possible for the responsible electrical engineer to detect and evaluate any residual current increases, and if necessary initiate remedial measures as quickly as possible.

### Stray currents impair EMC

Connections between the N and PE phase result in „stray“ operating currents being distributed across the PE system, via data lines and all metal building parts. Because these currents are not equalised, they generate electromagnetic fields. Diverse currents in the electrical systems, IT networks and pipe systems of building installations are the consequence. Image 12 shows how the operating current can distribute at the PEN bridge and flow back via multiple paths, whereby the sum of the supply and return conductor current is no longer 0. This can bring the following faults with it:

- Change in the operating behaviour of frequency-dependent parts (e.g. capacitors draw increased current)
- Data transfer disturbances due to magnetic and inductive influences
- Transfer of lightning influences to the electrical system
- Corrosion of metal lines
- Adverse effects on personnel

The supply and return conductors, also in distribution systems, must be positioned close to each other in order to minimise magnetic fields. At every node point in a current circuit the sum of the currents must be equal to zero, in order to avoid residual currents. Additionally, the sub-distribution or current circuit should be monitored by an RCM. The UMG 96RM-E is very well suited for monitoring sub-distribution or larger loads. Individual current circuits, in which no residual current circuit breakers can be used for operational reasons, can be monitored with the UMG 20CM. A signalling RCM in combination with the specialist personnel on location provides for the maximum alternative safety.

### Neutral conductor and CEP (Central earthing point)

The neutral conductor (operating current return conductor) has become the most important phase. It is to be treated as a phase conductor. In order that the earthing system remains „clean“, the current-loaded N phase must be positioned far from the PE phase. No galvanic operating currents may be permitted to flow via the earthing system because these would cause inductive couplings. These measures must be implemented right to the supply source.

In the TN-S system, the N phase must only be connected at a suitable point with the earthing system once – at the so-called CEP (central earth point from N to PE) – and monitored. Undesirable insulation faults or galvanic connections between N and PE are detected immediately with monitoring of the CEP. Deviations are reported in a timely manner and analysed with temporal dependencies.

It is possible to check that the TN-S system is functioning fault-free, e.g. with the UMG 512-PRO. This allows a holistic appraisal of the power quality and EMC. It is even possible to record and analyse the trigger phase of an earth short fault. The phase current increases in parallel to the CEP current in this case. The current at the CEP must always be appraised depending on the overall power of the TN-S system. On the one hand this means that operation-dependent leakage currents are tolerated, whilst abnormal deviations at the CEP are reported by the RCM.

**Summary and outlook**

Increasingly high demands will continue to be placed on future power supplies, because power failures result in high costs and huge disruption! Constant RCM monitoring for uptime power supplies with high EMC demands and also for preventative fire protection is becoming increasingly established. The aim here is RCM monitoring of the power supply across all four levels (supply [PCC], main distribution [transformer outputs], sub-distribution, individual loads [e.g. server cabinets]).

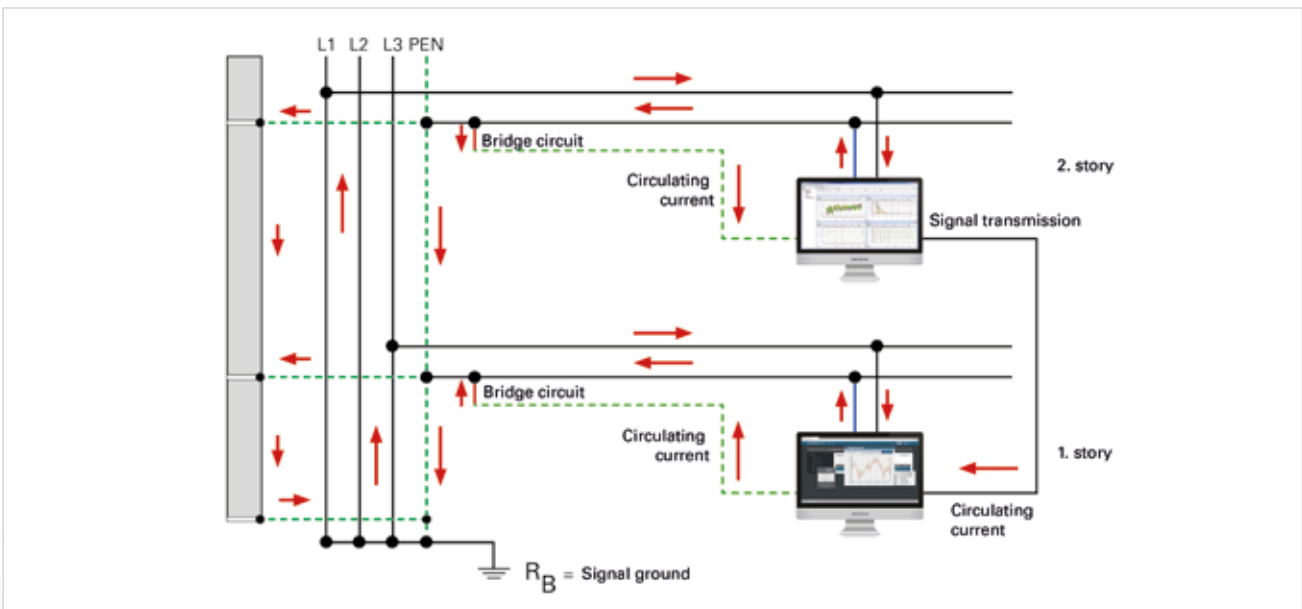


Fig. 12: Operating currents on earthing systems



# 11 Logistics information and T&Cs

- Logistics information
- Standard Terms and Conditions of Janitza electronics GmbH for the Sale of Standard Software
- Standard Terms and Conditions of Janitza electronics GmbH for the Provision of Software Free of Charge
- Green delivery conditions of the ZVEI:
  - General Conditions for the Supply of Products and Services of the Electrical and Electronics Industry
  - Supplementary Clause: Extended Retention of Title





# LOGISTICS INFORMATION AND T&CS





# Logistics information

Unit carton						
Type	Dimensions in mm (W x H x D)	Net weight of unit in kg	Gross weight in kg (mailable: incl. packing and operating manual etc.)	Device type	Number of units in package	Item number
Unit carton 1	180 x 85 x 145	0.3	0.4	UMG 96-S2	1	31.01.035
Unit carton 1	180 x 85 x 145	0.5	0.6	UMG 96RM / -M / -EL / ProData®	1	31.01.035
Unit carton 1	180 x 85 x 145	0.2	0.3	UMG 103-CBM	1	31.01.035
Unit carton 2	180 x 140 x 170	0.4	0.8	UMG 96RM-P / -PN / -CBM / -E UMG 96-PA / UMG 96-PQ-L	1	31.01.034
Unit carton 2	180 x 140 x 170	0.3	0.8	UMG 604-PRO / UMG 605-PRO / UMG 804	1	31.01.034
Unit carton 2	180 x 140 x 170	1.0	1.2	Prophi® / Prophi® 7	1	31.01.034
Unit carton 2*1	180 x 140 x 170	1.5	1.7	UMG 509-PRO / UMG 512-PRO / UMG 801	1	31.01.034

\*1 This packaging is not suitable for individual despatch of UMG 509-PRO, UMG 512-PRO and UMG 801; this is done with covering box 1.

Cardboard packaging sizes											
Type	Dimensions in mm (W x H x D)	Packaging weight in kg	Max number of unit carton 1 (see Tab. 1)	Total weight in kg with the respective device type*3			Max number of unit carton 2 (see Tab. 1)	Total weight in kg with the respective device type*3			
				UMG 96-S2	UMG 96RM / -M / -EL / ProData®	UMG 103-CBM		UMG 96RM-P / -PN / -CBM / -E / UMG 96-PA / UMG 96-PQ-L	UMG 604-PRO / UMG 605-PRO / UMG 804	Prophi®	UMG 509-PRO / UMG 512-PRO / UMG 801
Master carton 1	315 x 190 x 225	0.2	4	1.4	1.9	1.1	2	1.9	1.6	2.7	3.3
Master carton 2	400 x 250 x 300	0.4	10	4.2	6.0	3.4	4	5.0	3.5	5.9	6.9
Master carton 3	340 x 280 x 240	0.3	8	3.3	4.8	2.7	4	4.1	3.4	5.0	6.8
Master carton 4	400 x 550 x 240	0.8	18	7.7	11.0	6.3	8	8.5	7.1	10.3	13.9
Master carton 5	440 x 390 x 395	0.9	26	10.8	15.5	8.7	12	12.4	10.3	15.1	20.4
Master carton 6	700 x 400 x 400	1.4	40	16.6	23.8	13.4	20	20.5	17.0	25.1	33.8
Master carton 7	800 x 400 x 400	1.5	46	19.0	27.3	15.3	20	20.6	17.1	25.1	33.9
Master carton 8 on throw-away pallet*2	800 x 400 x 600	7.3	72	34.6	47.6	28.9	34	39.6	33.8	47.4	62.6
Master carton 9 on throw-away pallet*2	1180 x 905 x 780	14.8	280	123.1	175.4	102.6	128	140.2	118.4	169.6	226.0

\*2 Pallets are IPPC certified.

\*3 The details of the total weight of the respective unit type is based on a single variety only. Unit carton 1 and 2 is also used inside the master cartons.

Cardboard packaging sizes for 10 units project packaging (Art. No.: 31.01.040)						
Shipping packaging				Total weight in kg with the respective device type		
Type	Dimensions in mm (x D)	Max. number of units	10 % accessories (pcs.) instructions, crossover cable (only UMG 96RM-EL)	UMG 96-S2	UMG 96RM / -M / -EL, ProData® / UMG 96-PA / UMG 96-PQ-L	UMG 103-CBM
Master carton 4	400 x 550 x 240	40 (4 x 10 pcs.)	4	12	14	8
Master carton 5	440 x 390 x 395	60 (6 x 10 pcs.)	6	17	21	12
Master carton 6	700 x 400 x 400	90 (9 x 10 pcs.)	9	26	31	17
Master carton 8 on throw-away pallet*1	800 x 400 x 600	150 (15 x 10 pcs.)	15	49	57	34
Master carton 9 on throw-away pallet*1	1180 x 905 x 780	840 (84 x 10 pcs.)	84	260	305	176

- Dimensions: 10 units project packet (x D in mm): 105 x 225 x 315.
- Project packets will be packed with devices from one type.
- Project packaging include 100 % patch cable and 10 % other accessories! Mounting brackets will be consisting of 100 %.
- \*1 Pallets are IPPC certified.

Cardboard packaging sizes for 12 units project packaging (Art. No.: 31.01.042)							
Shipping packaging				Total weight in kg with the respective device type			
Type	Dimensions in mm (x D)	Max. number of units	10 % accessories (pcs.) instructions, crossover cable, screwdriver (only UMG 604-PRO / UMG 605-PRO)	UMG 96RM-CBM / -P	UMG 96RM-E / 96RM-PN, UMG 96-PA / UMG 96-PQ-L	UMG 604-PRO / UMG 605-PRO	UMG 804
Master carton 4	550 x 400 x 240	24 (2 x 12 pcs.)	3	11	12	10	10
Master carton 5	390 x 440 x 395	36 (3 x 12 pcs.)	4	17	17	15	15
Master carton 8 on throw-away pallet*1	400 x 800 x 600	96 (8 x 12 pcs.)	10	50	51	45	45
Master carton 9 on throw-away pallet*1	905 x 1180 x 780	468 (39 x 12 pcs.)	47	235	238	210	210

- Dimensions in mm (x D): 12 units project packet (foam inserts) 150 x 450 x 330.
- Project packets will be packed with devices from one type.
- Project packaging include 100 % patch cable and 10 % other accessories! Mounting brackets will be consisting of 100%.
- \*1 Pallets are IPPC certified.

# Standard Terms and Conditions of Janitza electronics GmbH for the Sale of Standard Software

## **§ 1 Applicability of the Terms and Conditions of Contract**

(1) Unless otherwise agreed, exclusively these Standard Terms and Conditions of Contract apply for the sale in business dealings of standard software by Janitza electronics GmbH, business domicile Vor dem Polstück 1, 35663 Lahnau, Germany (hereinafter called "JANITZA") and for pre-contractual obligations in this connection. Deviating terms and conditions of contract of the customer shall not form an integral part of the contract, even if JANITZA does not expressly contradict the same.

(2) Even if no reference is made to them once more upon the conclusion of similar contracts, exclusively the Standard Terms and Conditions of Contract of Janitza electronics GmbH for the Sale of Standard Software shall apply in the version applicable when the customer made his declaration (retrievable under [www.janitza.de](http://www.janitza.de)) unless the parties expressly agree otherwise in writing.

(3) Supplemental hereto, the statutory provisions apply; for the supply of the standard software, §§ 433 et seq. German Civil Code [Bürgerliches Gesetzbuch] (BGB), for separately ordered services (e.g. installation, parameterisation, training), §§ 611 et seq. BGB.

## **§ 2 Conclusion of the contract**

(1) Unless the offer is designated in writing as being binding, all offers of JANITZA are subject to confirmation and without obligation. A legal obligation only arises through a contract signed by both parties or by a written confirmation of order from JANITZA, or through JANITZA commencing with the performance in accordance with the terms of the contract. JANITZA may demand written confirmation of verbal declarations of contract by the customer.

(2) The customer shall be bound by declarations directed at the conclusion of a contract (offers of contracts) for a period of four weeks.

(3) For other types of deliveries and services (e.g. delivery of hardware, software support, set-up and installation of software) separate contracts are to be concluded.

## **§ 3 Object of the contract; Scope of performance**

(1) The object of these Terms and Conditions of Contract is only the delivery of standard software and the grant of rights of use in accordance with § 4, as well as training (if ordered) in accordance with § 15.

(2) Prior to the conclusion of the contract, the customer shall verify that the specifications of the software conform with his wishes and requirements. He is familiar with the essential functional features and conditions of the software.

(3) The scope, nature and quality of the deliveries and services shall be determined by the contract signed by both parties or the confirmation of order from JANITZA, or otherwise the offer from JANITZA. Other details or requirements shall only become an integral part of the contract if the parties agree this in writing or if JANITZA has confirmed them in writing. Subsequent changes to the scope of performance require written agreement or the written confirmation of JANITZA.

(4) Product descriptions, illustrations, test programmes etc. are performance specifications, but do not constitute any guarantees. A guarantee requires a written declaration by the management of JANITZA.

(5) The customer receives the software consisting of the machine programme and the user manual. The method of delivery of the software shall be determined by the agreements; in the absence of any other agreement, the programme and user manual will be delivered on a CDROM. The customer has no claim to be provided with the source programme.

(6) JANITZA will provide all deliveries and services using state-of-the-art systems and technologies.

#### **§ 4 Rights of the customer to the software**

(1) The software (programme and user manual) is legally protected. The copyright, patent rights, trademark rights and all other ancillary copyrights in the software, as well as all other items which JANITZA provides or makes available to the customer within the framework of the contractual negotiations and performance of the contract shall, in the relationship of the parties inter se, remain the sole property of JANITZA. Where such rights are held by third parties, JANITZA has the corresponding rights of use and exploitation.

(2) The customer shall only be entitled to process his own data himself and in his own operations and for his own purposes using the programme. All data processing equipment (e.g. hard disks and central processing units) on which the programmes are copied or transferred, either in whole or in part, either temporarily or permanently, must be located in the premises of the customer and be in his direct possession. Further contractual provisions governing use (e.g. the limitation to a number of workplaces or persons) are to be implemented in technical terms and complied with in practice. JANITZA hereby grants the customer the powers necessary for this use as a simple right of use, including the right to rectify faults. § 13 applies in respect of the period of the right of use.

(3) The customer may prepare such backup copies of the programmes as are necessary for his safe operations. The backup copies must be safely stored and, in so far as technically feasible, labelled with the copyright notice of the original data carrier. Copyright notices may not be deleted, altered or suppressed.

Copies which are no longer required must be deleted or destroyed. The user manual and other documents provided by JANITZA may only be copied for internal business purposes.

(4) The customer shall only be entitled to pass on the software or parts thereof to third parties in accordance with the following provisions and after carrying out the following procedures:

- a) Only an original data carrier (see § 3 (5)) may be passed on. Other software or software in another version may not be passed on.
- b) The customer must delete all other copies of the software (irrespective of the version), in particular on data carriers and on solid state memories or random access memories (RAM). He shall relinquish the use of the same. He undertakes to carry out these procedures prior to passing on the original data carrier to third parties and to confirm this to JANITZA in writing without delay.
- c) The transfer to third parties is permanent, that is to say without any claim for return or any option of repurchase.
- d) The third party must give a written declaration to JANITZA that it will comply with § 4, § 13 (2) and (3), § 14 and § 16 of these Standard Terms and Conditions of Contract directly vis-à-vis JANITZA.
- e) The written consent of JANITZA has been received. JANITZA shall be obliged to grant consent unless compelling reasons preclude the same (e.g. protection from competition).

In the case of any breach of these provisions by the customer, he shall be liable to pay JANITZA a contractual penalty equivalent to the amount that the third party would have to have paid for the software in accordance with the current price list of JANITZA, but at least the amount of the purchase price agreed hereunder. Further-reaching claims by JANITZA are reserved.

(5) The provisions under paragraphs (2), (3) and (4) (d) and (e) also apply where the customer rectifies a fault or (in so far as admissible) carries out any other modification of the programmes or uses the software for training purposes.

(6) The customer may only decompile the interface information of the programmes within the limits defined by § 69e German Copyright Act [Urheberrechtsgesetz] (UrhG), and then only after informing JANITZA in writing of his intent together with a request for the necessary information to be provided within a period of at least two weeks. § 14 shall apply to all knowledge and information which the customer may obtain in relation to the software during the decompiling process. Each time before involving third parties, the customer shall provide JANITZA with a written declaration from the third party that the latter undertakes directly vis-à-vis JANITZA to comply with the provisions laid down in §§ 4 and 14.

(7) No other forms of exploitation, in particular the leasing, rental or distribution in tangible or intangible form, the use of the software by and for third parties (e.g. outsourcing, computer centre operations, application service providing) are permitted without the prior written consent of JANITZA.

(8) Objects of the contract, documents, suggestions, test programmes etc. from JANITZA which become available to the customer either before or following the conclusion of the contract are deemed to be intellectual property and business and company secrets of JANITZA. They may not be used in any manner without the written permission of JANITZA and must be kept confidential in accordance with § 14.

### **§ 5 Performance periods; Delays; Place of performance**

(1) Details concerning times for delivery and performance are non-binding unless they are designated by JANITZA in writing as being binding. JANITZA may render partial performance if the parts delivered can expediently be used by the customer.

(2) The periods for delivery and performance shall be extended by such periods during which the customer is in default of payment under the contract and by any periods during which JANITZA is prevented from delivery or performance by circumstances for which JANITZA is not responsible, plus a reasonable start-up time following the end of the circumstances causing the prevention. Such circumstances also include force majeure and labour disputes. Periods for delivery and performance shall also be extended by any such period during which the customer, in breach of contract, fails to comply with his obligations of cooperation, e.g. fails to provide information, to grant access, to supply materials or facilities or to make staff available.

(3) Should the parties subsequently agree upon different or additional performances which affect the periods agreed, these periods shall be extended by a reasonable period of time.

(4) Formal warnings and the setting of time limits by the customer shall only be effective if made in writing. Any extension of the time for performance must be reasonable. A period of less than two weeks shall only be deemed to be reasonable in cases of special urgency.

(5) The place of performance for training sessions shall be the location where the training sessions are to take place. In all other cases, the place of performance for all performances under and in connection with this contract shall be the location of the head office of JANITZA.

### **§ 6 Contractual commitment and termination of the contract**

(1) Any termination of the further exchange of performances (e.g. rescission of the contract, claim to a reduction in price, termination for compelling reasons, claim for damages in lieu of performance) must always be threatened specifying the grounds and setting a reasonable period for rectification (as a rule, at least two weeks) and may only be declared within two weeks of the notice having elapsed. In the cases stipulated by law (see § 323 (2) BGB) the setting of a deadline may be dispensed with. The party who is entirely or predominantly responsible for the disturbance shall not be entitled to demand rescission of the contract.

(2) All declarations in this connection must be made in writing in order to be effective.

### **§ 7 Remuneration; Payment**

(1) The agreed remuneration shall become due and payable without any deduction within 14 days of delivery of the software (in the case of training sessions, after completion of the training course) and receipt of the invoice by the customer.

(2) Unless otherwise agreed, the respective price list of JANITZA, which can be requested from JANITZA, applies.

(3) Travel costs, expenses, accessories, shipping costs and telecommunication costs are to be reimbursed in addition according to time and material expended. Any additional performances or services demanded by the customer (e.g. advice and support in the programme installation) will be invoiced in accordance with the respective current price list of JANITZA. Any increase in the list price shall be limited to 3 % per year.

(4) Value added tax will be added to all prices.

(5) The customer may only set off claims of his own against claims of JANITZA if such claims are undisputed or have been judicially decided and are final and legally binding. Except as provided in § 354 a German Commercial Code [Handelsgesetzbuch] (HGB), the customer may only assign claims under this contract to third parties with the previous written consent of JANITZA. The customer shall only be entitled to exercise a right of withholding or to raise the defence of non-performance of the contract within the scope of this contractual relationship.

#### **§ 8 Duties of the customer**

(1) The customer shall, in accordance with the commercial law provisions (§ 377 German Commercial Code (HGB)), be obliged to have a competent employee inspect all items delivered by JANITZA immediately following delivery or upon their becoming accessible and to notify JANITZA in writing of any flaws discovered, giving a precise description of the defect. The customer shall thoroughly test each module as to its usability in the specific situation before commencing productive use. This also applies to programmes which the customer receives within the scope of the warranty or a service contract.

(2) The customer shall take reasonable precautions (e.g. through data backups, fault diagnosis, regular examination of the results, emergency planning) in order to deal with a situation in which the programme, either in whole or in part, does not work properly. It is the responsibility of the customer to ensure the functionality of the working environment of the programme.

#### **§ 9 Material defects**

(1) The software has the agreed features and is suitable for the contractually specified use or, in the absence of any such agreement, for normal use. It satisfies the criterion of practical fitness for its purpose and has the quality typical of software of this type; however, it is not free from faults. Any impairment in the functioning of the programme which results from hardware defects, environmental conditions, faulty operation or such like does not constitute a defect. A negligible reduction in quality is to be disregarded.

(2) In the case of material defects, JANITZA may in the first instance provide subsequent performance. Subsequent performance shall, at the option of JANITZA, be effected through rectification of the defect, through delivery of software which is free from defects, or through JANITZA demonstrating possibilities of avoiding the effects of the defect. The customer shall acquiesce in at least three attempts to remedy the defect. The customer shall accept an



equivalent new programme version or the equivalent previous programme version which did not contain the fault where this is conscionable for him.

(3) The customer shall support JANITZA in the analysis of faults and the rectification of defects, in particular through providing a detailed description of the problems arising. He shall provide JANITZA with comprehensive information and grant JANITZA the time and opportunity necessary to rectify the defect. JANITZA may, at its option, rectify the defect on site or at the business premises of JANITZA. JANITZA may also provide services by means of remote maintenance. The customer shall at his own expense ensure that the necessary technical pre-requisites are available and, following corresponding notice, grant JANITZA access to his EDP system.

(4) The parties agree the following error classes and reaction times:

a) Error class 1: Operation-impeding defects: the error prevents the business operations of the customer; no work-around solution is available: JANITZA shall start with the rectification of the error immediately, no later than within six hours following the error notification, and shall continue with appropriate commitment until the error is rectified, in so far as can reasonably be expected also outside normal working hours (workdays from 8:00 am to 5:00 pm).

b) Error class 2: Operation-hindering defects: the error considerably hinders the business operations of the customer; however, the use of the software is possible with work-around solutions or with temporarily acceptable limitations or difficulties: Where the error notification is received before 10:00 am, JANITZA shall start with the rectification of the error on the same day; where the error notification is received later, JANITZA shall start with the rectification of the error at the beginning of the following working day and shall continue within normal working hours until the error has been rectified. JANITZA may in the first instance demonstrate a work-around solution and rectify the error later if this is conscionable for the customer.

c) Error class 3: Other defects: JANITZA shall start with the rectification of the error within one week or shall rectify the error with the next programme version if this is conscionable for the customer.

(5) The time periods under para. (4) begin with an error notification in accordance with § 8 (1). § 5 (2) and (3) apply for the purpose of calculation of the time periods. In the case of a difference of opinion on the assignment of an error into the classes in accordance with para. (4), the customer may demand classification into a higher error class. Should the customer fail to prove that his classification was correct, he shall reimburse JANITZA the additional expenditure.

(6) JANITZA may make additional charges which arise from the software having been modified, used outside the prescribed environment or improperly operated. JANITZA may demand reimbursement of its expense if no defect is found. The burden of proof lies with the customer. § 254 German Civil Code (BGB) applies correspondingly.

(7) If JANITZA ultimately refuses to rectify the defect or such rectification is ultimately unsuccessful or is unconscionable for the customer, the customer may, within the scope of § 6, either cancel the contract or curtail the remuneration

by a reasonable amount and additionally demand damages or reimbursement of his expenses in accordance with § 11. The claims shall lapse by limitation in accordance with the terms of § 12.

#### **§ 10 Flaws in legal title**

(1) JANITZA warrants that no rights of third parties preclude the use of the software by the customer in accordance with the terms of the contract. In the case of flaws in legal title, JANITZA warrants that it will, at the option of JANITZA, procure for the customer a legally unchallengeable possibility of use of the software or of equivalent software.

(2) The customer shall inform JANITZA in writing without delay if any third party asserts industrial property rights (e.g. copyright or patent rights) against him in respect of the software. The customer authorises JANITZA to conduct the dispute with the third party alone. So long as JANITZA avails itself of this authorisation, the customer may not of his own initiative acknowledge the claims of the third party without the consent of JANITZA; JANITZA shall then at its own expense avert the claims of the third party and shall indemnify the customer from all costs associated with averting such claims except in so far as these result from conduct on the part of the customer in breach of duty (e.g. use of the programmes in breach of the terms of the contract).

(3) § 9 (2), (6) and (7) apply correspondingly. § 6 shall apply for the discontinuance of the exchange of performances. § 11 shall apply in relation to liability; § 12 in relation to the limitation period.

#### **§ 11 Liability**

(1) JANITZA shall be liable in accordance with the statutory provisions in so far as the customer asserts claims for damages based on deliberate intent or gross negligence, including the deliberate intent or gross negligence of representatives or vicarious agents of JANITZA.

(2) In the case of ordinary (that is to say, not grossly) negligent breaches of such contractual duties, the fulfilment of which actually enables the contract to be properly performed at all and upon compliance with which a client regularly relies and is entitled to rely (cardinal duties, fundamental contractual duties) JANITZA shall be liable in accordance with the statutory provisions. In such case, however, the liability of JANITZA shall be limited to the damage foreseeable and typically arising according to the nature of the performance; the reimbursement of consequential damage such as e.g. loss of profit is excluded. The same shall apply to grossly negligent breaches of non-fundamental contractual duties committed by the simple vicarious agents of JANITZA.

(3) JANITZA shall not be liable for ordinary (that is to say, not grossly) negligent breaches of non-fundamental contractual duties.

(4) The limitations and exclusions of liability in accordance with paras. (1), (2) and (3) shall also apply for claims arising for liability in connection with the conclusion of the contract (culpa in contrahendo), other breaches of duty or in tort. They shall not apply to injury to life, limb or health attributable to JANITZA or to claims under the Product Liability Act [Produkthaftungsgesetz].

(5) JANITZA shall be free to raise the defence of contributory negligence. The customer is, in particular, under an obligation to prepare data back-ups and to protect his system from malicious software in accordance with the latest state of technology.

### **§ 12 Limitation period**

(1) The period of limitation shall be:

a) one year starting with the delivery of the software for claims to repayment of the purchase price arising from cancellation of the contract or curtailment of the purchase price, however not less than three months as from the issue of the legally effective declaration of cancellation or curtailment of the price in the case of properly lodged complaints;

b) one year for other claims arising from material defects;

c) two years in the case of claims arising from flaws in legal title if the flaw lies in a right in rem of a third party by reason of which it may demand the surrender of the items specified in § 3 (5) or demand that the customer desists from using the same;

d) two years in the case of claims for damages not based on material defects or flaws in legal title or for reimbursement of expenditure incurred in vain, commencing at the point in time at which the customer obtained knowledge of the circumstances substantiating the claim or must have attained knowledge of the same without gross negligence on his part.

The claims shall be barred by limitation no later than upon the expiration of the maximum periods specified in § 199 German Civil Code (BGB).

(2) However, the statutory periods of limitation shall always apply in the case of claims for damages and reimbursement of expenditure incurred in vain arising from deliberate intent, gross negligence, guarantee, fraudulent intent and in the cases mentioned in § 11 (3).

### **§ 13 Commencement and end of the rights of the customer**

(1) Ownership of items delivered and the rights pursuant to § 4 hereof shall only pass to the customer upon payment in full of the remuneration in accordance with the terms of the contract. Prior to this, the customer shall only have a temporary, contractual right of use which is revocable in accordance with para. (2).

(2) JANITZA may revoke the rights under § 4 for compelling reasons in accordance with the conditions of § 6. A compelling reason exists in particular if JANITZA cannot reasonably be expected to continue to maintain the contract in force, in particular where the customer fails to pay the remuneration or commits a significant breach of § 4.

(3) Should the rights under § 4 not come into existence or should they end, JANITZA may demand of the customer that he return the items provided or submit a written declaration that they have been destroyed, as well as the deletion or destruction of all copies of the items provided and a written assurance that this has taken place.

#### **§ 14 Confidentiality**

(1) Each party to the contract undertakes, also beyond the end of the contract, to treat as confidential all items provided to it by the respective other party or which have otherwise become known to it before or during the performance of the contract (e.g. software, documents, information) and which are legally protected or contain business or company secrets or are otherwise designated as being confidential unless such items are already in the public domain without any breach of the duty of confidentiality. The parties shall store and secure these items in such a way as to ensure that no third party has access to them.

(2) The customer shall only make the objects of the contract accessible to those employees and other third parties who require access to the same for the performance of their contractual duties. The customer shall instruct these persons regarding the necessity of maintaining confidentiality in relation to the items in question.

(3) JANITZA shall process the necessary customer data relevant for handling the business transaction in due compliance with the data protection provisions. JANITZA may name the customer as a reference customer following the successful conclusion of its services.

#### **§ 15 Training**

(1) In so far as training courses are contractually agreed, these shall, at the option of JANITZA, be held at the premises of the customer or at another location designated in agreement with the customer. Where the training courses are held at the premises of the customer, the latter shall, following consultation with JANITZA, provide the necessary rooms and technical equipment. Where training courses are held elsewhere, the customer shall rent the premises and make the necessary hardware and software available on site.

(2) JANITZA may cancel a training session for compelling reasons. JANITZA shall notify the customer of any cancellation in due time and offer substitute dates.

(3) In the case of justified dissatisfaction of the customer, JANITZA shall be given the opportunity to remedy the matter. In further respects, § 6 shall apply.

#### **§ 16 Final provisions**

(1) Any amendments and supplements to the contract need to be made in writing in order to be effective. The requirement of the written form may only be revoked in writing. Transmission in text form, in particular by fax or e-mail, shall suffice to satisfy the requirement of the written form.

(2) The customer may only set off claims of his own against claims of JANITZA if such claims are undisputed or have been judicially decided and are final and legally binding. Except as provided in § 354 a German Commercial Code [Handelsgesetzbuch] (HGB), the customer may only assign claims under this contract to third parties with the previous written consent of JANITZA. The customer shall only be entitled to exercise a right of withholding or to raise the

defence of non-performance of the contract within the scope of this contractual relationship.

(3) These Terms and Conditions of Contract shall be governed by the law of the Federal Republic of Germany to the exclusion of the UN Convention on Contracts for the International Sale of Goods.

(4) In the case of contracts with business persons, public legal entities or bodies of public assets the place of performance and court venue for all disputes arising under and in connection with this contract shall be the location of the head office of JANITZA.

(5) In the case of any inconsistencies between the German version of these Terms and Conditions of Contract and any translations, the German version of these Terms and Conditions of Contract is binding.

## Standard Terms and Conditions of Janitza electronics GmbH for the Provision of Software Free of Charge

### **§ 1 Applicability of the Terms and Conditions of Contract**

(1) Unless otherwise agreed, exclusively these Standard Terms and Conditions of Contract apply for the provision of software free of charge to the user by Janitza electronics GmbH, business domicile Vor dem Polstück 1, 35663 Lahnau, Germany (hereinafter called "JANITZA"). Deviating terms and conditions of contract of the user shall not form an integral part of the contract, even if JANITZA does not expressly contradict the same.

(2) Even if no reference is made to them once more upon the conclusion of similar contracts, exclusively the Standard Terms and Conditions of Contract of Janitza electronics GmbH for the Provision of Software Free of Charge shall apply in the version applicable when the user made his declaration (retrievable under [www.janitza.com](http://www.janitza.com)) unless the parties expressly agree otherwise in writing.

(3) Supplemental hereto, the statutory provisions apply; for this provision of software free of charge, in particular § 516 et seq. German Civil Code [Bürgerliches Gesetzbuch] BGB (gift).

### **§ 2 Conclusion of the contract**

(1) The contract is concluded in such manner that JANITZA, at the request of the user for the provision of the software free of charge, sends him an e-mail in confirmation and subsequently does actually provide the user with the free software (including the pertinent data carrier, in so far as available).

(2) Both parties are in agreement that the provision / gratuitous transfer of the software (and of the pertinent data carrier, in so far as relevant) is made free of charge.

(3) A binding contract is not formed until the software is actually provided (in accordance with § 518 (1) German Civil Code (BGB), a promise of a gift needs to be recorded before a notary; this deficiency in form is only cured through the actual transfer, § 518 (2) BGB).

(4) For other types of deliveries and services (e.g. delivery of hardware, software support, set-up and installation of software, training sessions) separate contracts are to be concluded.

### **§ 3 Object of the contract; Scope of performance**

(1) The object of these Terms and Conditions of Contract is the provision of software free of charge (including the pertinent data carrier, in so far as available) to the user and the grant of the rights of use in accordance with § 4.

(2) The free software (including the pertinent data carrier, in so far as available) is transferred in the status in which it is available to JANITZA at the point in time of the transfer ("as is").

(3) Prior to the conclusion of the contract, the user shall verify that the specifications of the software conform with his wishes and requirements. He is familiar with the essential functional features and conditions of the software corresponding to the product description of JANITZA.

(4) According to the current state of technology, it is not possible to prepare software programmes which work without faults in all cases of application. Product descriptions, illustrations, test programmes etc. are therefore general performance specifications, but do not constitute any guarantees. A guarantee requires a written declaration by the management of JANITZA.

(5) The user will receive the software consisting of the machine programme and, in so far as available for the relevant software, a user manual in the form of a file. The method of the delivery of the software shall be determined by the agreements; in the absence of any other agreement, the programme and user manual will be delivered on a USB stick by post. The user has no claim to be provided with the source programme.

### **§ 4 Rights of the user to the software**

(1) The software provided free of charge (programme and user manual) is legally protected. The copyright, patent rights, trademark rights and all other ancillary copyrights in the software, as well as all other items which JANITZA provides or makes available to the user within the framework of the contractual negotiations and performance of the contract shall, in the relationship of the parties inter se, remain the sole property of JANITZA. Where such rights are held by third parties, JANITZA has the corresponding rights of use and exploitation.

(2) The user shall only be entitled to process his own data himself and in his own operations and for his own purposes using the programme. All data processing equipment (e.g. hard disks and central processing units) on which the programmes are copied or transferred, either in whole or in part, either temporarily or permanently, must be located in the premises of the user and be in his direct possession. Further contractual provisions governing use (e.g. the limitation to a number of workplaces or persons) are to be implemented in

technical terms and complied with in practice. JANITZA hereby grants the user the powers necessary for this use as a simple right of use, including the right to rectify faults. § 10 applies in respect of the period of the right of use.

(3) The user may prepare such backup copies of the programmes, as are necessary for his safe operations. The backup copies must be safely stored and, in so far as technically feasible, labelled with the copyright notice of the original data carrier. Copyright notices may not be deleted, altered or suppressed. Copies which are no longer required must be deleted or destroyed. The user manual and other documents provided by JANITZA may only be copied for internal business purposes.

(4) The user shall only be entitled to pass on the software or parts thereof free of charge to third parties in accordance with the following provisions and after carrying out the following procedures:

a) Only one original data carrier may be passed on. Other software or software in another version may not be passed on.

b) The user must delete all other copies of the software (irrespective of the version), in particular on data carriers and on solid state memories or random access memories (RAM). He shall relinquish the use of the same. He undertakes to carry out these procedures prior to passing on the original data carrier to third parties and to confirm this to JANITZA in writing without delay.

c) The transfer to third parties is permanent, that is to say without any claim for return or any option of repurchase.

d) The third party must give a written declaration to JANITZA that it will comply with § 4, § 10 (2) and (3), § 11 and § 12 of these Standard Terms and Conditions of Contract directly vis-à-vis JANITZA.

e) The written consent of JANITZA has been received. JANITZA shall be obliged to grant consent unless compelling reasons preclude the same (e.g. protection from competition).

In the event of any breach of these provisions by the user, JANITZA reserves the right to claim damages.

(5) The provisions under paras. (2), (3) and (4 d), (e) also apply where the user eliminates the fault or (in so far as admissible) carries out any other modification of the programmes or uses the software for training purposes.

(6) The user may only decompile the interface information of the programmes within the limits defined by § 69 e German Copyright Act [Urheberrechtsgesetz] (UrhG), and then only after informing JANITZA in writing of his intent together with a request for the necessary information to be provided within a period of at least two weeks. § 11 shall apply to all knowledge and information which the user may obtain in relation to the software during the decompiling process. Each time before involving third parties, the user shall provide JANITZA with a written declaration from the third party that the latter undertakes directly vis-à-vis JANITZA to comply with the provisions laid down in §§ 4 and 11.

(7) No other forms of exploitation, in particular the sale, leasing, rental or distribution in tangible or intangible form, the use of the software by and for third parties (e.g. outsourcing, computer centre operations, application service providing) are permitted without the prior written consent of JANITZA.

(8) Objects of the contract, documents, suggestions, test programmes etc. from JANITZA which become available to the user either before or following the conclusion of the contract are deemed to be intellectual property and business and company secrets of JANITZA. They may not be used in any manner without the written permission of JANITZA and must be kept confidential in accordance with § 11.

#### **§ 5 Place of performance**

The place of performance for all performances under and in connection with this contract shall be the location of the head office of JANITZA.

#### **§ 6 Duties of the user**

(1) The user shall be obliged to test the programme thoroughly as to its usability in the specific situation before commencing any productive use.

(2) The user shall be obliged to take reasonable precautions (e.g. through data back-ups, fault diagnosis, regular examination of the results, emergency planning) in order to deal with a situation in which the programme, either in whole or in part, does not work properly. It is the responsibility of the user to ensure the functionality of the working environment of the programme.

#### **§ 7 Material defects**

(1) The liability of JANITZA as towards the user for material defects in the software provided (including the pertinent data carrier, in so far as available) shall be restricted to the case of JANITZA fraudulently concealing from the user any material defect in the software. In such case, JANITZA shall reimburse the user the damage arising therefrom in accordance with § 524 (1) German Civil Code (BGB).

(2) The user shall have no claim to have defects rectified by JANITZA in the case of software provided free of charge.

#### **§ 8 Flaws in legal title**

(1) The liability of JANITZA as towards the user for flaws in the rights to the software provided (including the pertinent data carrier, in so far as available) shall be restricted to the case of JANITZA fraudulently concealing from the user any flaw in the rights to the software. In such case, JANITZA shall reimburse the user the damage arising therefrom in accordance with § 523 (1) German Civil Code (BGB).

(2) The user shall inform JANITZA in writing without delay if any third party asserts industrial property rights (e.g. copyright or patent rights) against him in respect of the software. The user authorises JANITZA to conduct the dispute with the third party alone. So long as JANITZA avails itself of this authorisation, the user may not of his own initiative acknowledge the claims of the third



party without the consent of JANITZA; JANITZA shall then at its own expense avert the claims of the third party and shall indemnify the user from all costs associated with averting such claims except in so far as these result from conduct on the part of the user in breach of duty (e.g. use of the programmes in breach of the terms of the contract).

### **§ 9 Liability**

(1) With the exception of liability for material defects and flaws in legal title (see above §§ 7, 8), JANITZA shall only be liable in accordance with § 521 BGB in so far as the user asserts claims for damages based on deliberate intent or gross negligence, including the deliberate intent or gross negligence of representatives or vicarious agents of JANITZA.

(2) JANITZA shall be free in each case to raise the defence of contributory negligence. The user is, in particular, under an obligation to prepare data backups and to protect his system from malicious software in accordance with the latest state of technology.

### **§ 10 Commencement and end of the rights of the user**

(1) Ownership of the items provided and the rights pursuant to § 4 hereof shall pass to the user upon the transfer of the same.

(2) JANITZA may revoke the rights under § 4 for compelling reasons. A compelling reason exists in particular if JANITZA cannot be reasonably expected to continue to maintain the contract in force, in particular where the user commits a significant breach of § 4.

(3) Should the rights under § 4 not come into existence or should they end, JANITZA may demand of the user that he return the software provided or submit a written declaration that it has been destroyed, as well as the deletion or destruction of all copies of the software and a written assurance that this has taken place.

### **§ 11 Confidentiality**

(1) Each party to the contract undertakes, also beyond the end of the contract, to treat as confidential all items provided to it by the respective other party or which have otherwise become known to it before or during the performance of the contract (e.g. software, documents, information) and which are legally protected or contain business or company secrets or are otherwise designated as being confidential, unless such items are already in the public domain without any breach of the duty of confidentiality. The parties shall store and secure these items in such a way as to ensure that no third party has access to them.

(2) The user shall only make the objects of the contract accessible to those employees and other third parties who require access to the same for the performance of their contractual duties. The user shall instruct these persons regarding the necessity of maintaining confidentiality in relation to the items in question.

(3) JANITZA shall process the necessary user data relevant for handling the business transaction in due compliance with the data protection provisions. JANITZA may name the user as a reference user following the successful conclusion of its services.

#### **§ 12 Final provisions**

(1) Any amendments and supplements to the contract need to be made in writing in order to be effective. The requirement of the written form may only be revoked in writing. Transmission in text form, in particular by fax or e-mail, shall suffice to satisfy the requirement of the written form.

(2) These Terms and Conditions of Contract shall be governed by the law of the Federal Republic of Germany to the exclusion of the UN Convention on Contracts for the International Sale of Goods.

(3) The user may only set off claims of his own against claims of JANITZA if such claims are undisputed or have been judicially decided and are final and legally binding. Except as provided in § 354 a German Commercial Code [Handelsgesetzbuch] (HGB), the user may only assign claims under this contract to third parties with the previous written consent of JANITZA. The user shall only be entitled to exercise a right of withholding or to raise the defence of non-performance of the contract within the scope of this contractual relationship.

(4) In the case of contracts with business persons, public legal entities or bodies of public assets the place of performance and court venue for all disputes arising under and in connection with this contract shall be the location of the head office of JANITZA.

(5) In the case of any inconsistencies between the German version of these Terms and Conditions of Contract and any translations, the German version of these Terms and Conditions of Contract is binding.

## Green delivery conditions of the ZVEI

The "Green delivery conditions" published by ZVEI constitute an industry standard due to their broad distribution and are recognised well beyond the boundaries of the electrical industry.

The "Green delivery conditions" are comprised as follows:

1. General conditions for the Supply of Products and Services of the Electrical and Electronics Industry
2. Supplementary Clause: Extended Retention of Title

Janitza electronics GmbH makes documents available to download under the link <http://www.janitza.com>

The contents, performance features and diagrams provided in this catalogue are not always reflective of the actual case in their described form and may also be subject to change due to ongoing product developments. The text and images contained herein have been generated with due care and diligence. However, it is not possible to fully exclude errors from arising. The desired performance features are only binding if these are expressly agreed upon conclusion of the contract. Subject to technical change and delivery amendments.

The trade names, brand names and trade descriptions etc. provided in this catalogue are subject to the guidelines of the respective manufacturer.

Janitza electronics GmbH does not guarantee to keep this catalogue up-to-date.

Further up-to-date information can be found at [www.janitza.com](http://www.janitza.com)

Janitza electronics GmbH  
Vor dem Polstück 6 | 35633 Lahnau  
Germany

Tel.: +49 6441 9642-0  
info@janitza.com | www.janitza.com

Sales partner

Item no.: 33.03.753 • Dok-Nr.: 2.500.082.9f • Stand 07/2021 • Subject to technical alterations.  
The current brochure is always available for you under [www.janitza.com](http://www.janitza.com)