

Control unit SG-RS 309-2



EN | Operating instructions

Version 1

1006747

SG-RS 309-2

DC 24 to 36 V / 8k2, 10k

Mayser GmbH & Co. KG

Örlinger Straße 1-3

89073 Ulm

GERMANY

Phone: +49 731 2061-0

Fax: +49 731 2061-222

E-mail: info.ulm@mayser.com

Internet: www.mayser.com

Safety first!



- Read the manual carefully before use.
- Warning signs in the manual warn of unexpected dangers. Always observe warning signs.
- Retain the manual throughout the service life of the product.
- Pass the manual on to every subsequent owner or user of the product.
- Insert every supplement received from the manufacturer into the manual.
- **Observe chapter on Safety starting on page 5.**

Conformity



The design type of the product complies with the basic requirements of the following directives:

- 2006/42/EC (Safety of Machinery)
- 2011/65/EU (RoHS)
- 2014/30/EU (EMC)

The Declaration of Conformity is available in the download section of the website: www.mayser.com.

EC design test

The product was tested by an independent institute.
An EC design type test certificate confirms conformity.

The EC design type test certificate is available in the download section of the website: www.mayser.com.

Copyright

The reproduction, distribution and utilization of this document as well as the communication of its contents without express authorization are prohibited. Offenders will be held liable for the payment of damages. All rights reserved in the event of the grant of a patent, utility model or design.

© Mayser Ulm 2021

Contents

About this manual	4
Safety.....	5
Intended use	5
Safety instructions.....	5
Residual dangers	6
Parts supplied	7
Storage	7
Product overview.....	7
Connections.....	7
LED indicators.....	8
Operation.....	8
Reset.....	9
Automatic reset.....	9
Controlled reset.....	9
Manual reset	10
Installation.....	11
Reset.....	12
Automatic reset.....	12
Controlled reset.....	12
Manual reset	13
Signal outputs.....	13
Connection examples	13
Commissioning.....	15
Testing.....	15
Automatic reset.....	15
Controlled reset and manual reset.....	16
Pressure-sensitive protection device actuated.....	17
Correlations	18
Decommissioning	18
Recommissioning.....	18
Maintenance and cleaning.....	19
Maintenance	19
Cleaning	19
Troubleshooting and remedies	19
Replacement parts	21
Disposal	21
Technical data.....	22

About this manual

This manual is an integral part of the product.
 Mayser will assume no liability and provide no guarantee whatsoever for damages and consequential damages resulting from failure to comply with the manual.

Validity

This manual is valid only for the product specified on the title page.

Target group

This manual is intended for the owner and electricians. The electrician must be familiar with the installation and commissioning.



Other applicable documents

- ➔ Also observe the following documents:
 - Drawing of the sensor system (optional)
 - Wiring diagram (optional)
 - Installation instructions of the sensors used

Symbols used

Symbol	Meaning
➔ ...	Action with one or more steps whose order is not relevant.
1. ...	Action with several steps whose order is relevant.
• ... - ...	Bullets first level Bullets second level
(see Section <i>Installation</i>)	Cross-reference

Danger symbols and information

Symbol	Meaning
 DANGER	Immediate danger leading to death or serious injury.
 WARNING	Imminent danger which may lead to death or serious injury.
 CAUTION	Possible danger which may lead to minor or moderate injuries.
NOTE	Potential danger of property damage or environmental degradation. Information on easier and safer working practices.

Dimensions in drawings

Unless otherwise indicated, all dimensions are stated in millimetres (mm).

Safety

Intended use

The control unit is designed for signal processing of a pressure-sensitive protective device (PSPD). It evaluates the output signals of sensors with monitoring resistor 8k Ω or 10k Ω . The integrated output signal switching devices (OSSD) transmit the evaluated safety signals directly to the downstream control.

The product complies with ISO 13849-1:2015 Category 3 PL d. So that the safety classification is retained, the downstream control must be of the same or a higher category.

The product has been developed taking EN 50155 into consideration and is suitable for rail applications.

Safety instructions

For your **own safety** the following safety instructions apply.

➔ **Prevent electric shock**

When working on electrical systems, always disconnect them from the power supply and secure them against being switched on again, to prevent injuries from electric shock.

➔ **Ensure careful configuration of interface**

The quality and reliability of the interface between the safety device and the machine affects the overall safety. Take special care when setting up this interface.

➔ **Prevent restarting of the machine**

As long as a hazard continues to exist, take measures to prevent the machine from restarting, for example by means of a startup lockout.

➔ **Disable in case of error**

Disable the safety device in case of malfunctions or visible damage.

➔ **Do not use in ATEX zones**

Do not use the control unit in potentially explosive environments (ATEX). The control unit is not authorised for use in these zones.

To prevent irreparable damage to the **product**, the following safety instructions apply.

➔ **Do not open the control unit**

Never open, tamper with or alter the control unit.

→ Observe degree of protection

Only use the control unit in rooms with a minimum degree of protection of IP54 (e.g. switch cabinet).

→ Maintain distance

When installing in the switch cabinet, ensure sufficient distance from heat sources (at least 2 cm).

→ Check supply voltage

Check supply voltage. It must correspond with the connecting voltage U_s on the type plate.

→ Observe pin assignment

Observe pin assignment when connecting the supply voltage.

→ Do not exceed the maximum number of sensors

Do not connect more sensors on the control unit, than the number specified in the installation instructions of the sensors.

→ Do not overload control unit

Ensure that the specified switching current is not exceeded.

→ Fit spark absorbers

When connecting inductive loads, fit spark absorbers (RC modules) to the consumer.

→ Do not cross link control unit

Do not cross link the control unit with other control units.
Die Klemmen Y1, Y2 und Y3, Y4 sind nicht potenzialfrei.

→ Continue redundancy

Make sure you wire the unit directly in the control circuit or that the downstream control is also in dual channel mode.

→ Protect against strong electromagnetic signals

Protect the control unit against excessive EMC radiation. A strong electromagnetic signal can cause the control unit to switch to a safe OFF state.

Residual dangers

There are no known residual dangers associated with this product.

Parts supplied

1× Control unit

Enclosure with electronics module and plug-in connectors.

1× Operating instructions

1× Declaration of Conformity

- ➔ Upon receipt of the parts supplied, check immediately for completeness and good condition.

Storage

- ➔ Store the control units in the original package, in a dry place.
- ➔ Comply with the storage temperature specified in the technical data.

Product overview

Connections

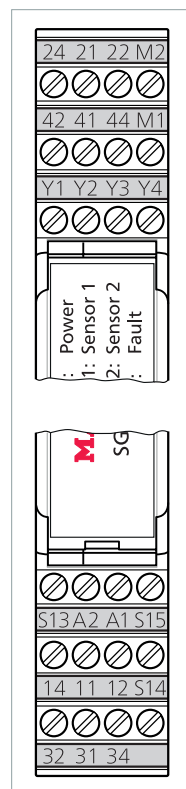

Terminals:

- A1, A2
- Input Sensor:
 - Y1, Y2
 - Y3, Y4
- Reset

- S13, S15
- S14, S15
- S13, S14
- S14

Monitoring circuit 1 (Sensor 1)

- 12 Semiconductor output OSSD 1.1
- 32 Semiconductor output OSSD 1.2
- M1 Signal output

Monitoring circuit 2 (Sensor 2)

- 22 Semiconductor output OSSD 2.1
- 42 Semiconductor output OSSD 2.2
- M2 Signal output

- 11, 14; 31, 34
- 21, 24; 41, 44

Connections:

Supply voltage

- Sensor 1
- Sensor 2

- Bridge automatic reset
- Bridge automatic reset
- Button for manual reset
- Input controlled reset

- without function
- without function

LED indicators

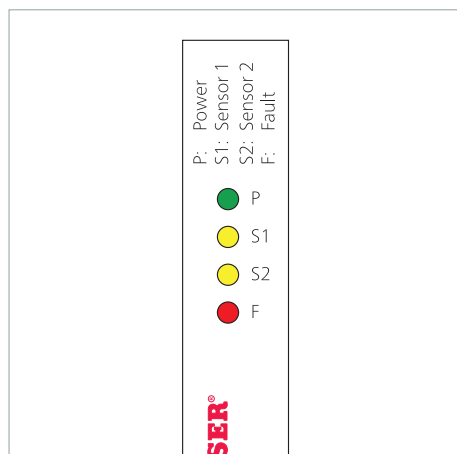

- green LED „P“ (Power):
Supply voltage connected
- yellow LED „S1“ (Sensor 1):
Sensor 1 activated
- yellow LED „S2“ (Sensor 2):
Sensor 2 activated
- red LED „F“ (Fault):
Fault / Error

Operation

The single-fault-safe electronics module has dual channels (redundant). Two monitoring circuits each control two semiconductor outputs (OSSD 1.1, 1.2 and 2.1, 2.2) and regularly monitor them to make sure they are working. The electronics monitor the electrical resistance of the connected sensors which have a defined closed-circuit current.

Ready for operation

The control unit is powered with DC 24 to 36 V. When the supply voltage is connected, the green LED “P” is lit.

When the sensors are not activated, the OSSDs from monitoring circuit 1 (OSSD 1.1, OSSD 1.2) and monitoring circuit 2 (OSSD 2.1, OSSD 2.2) are in the ON state. The signal outputs from monitoring circuit 1 (M1) and monitoring circuit 2 (M2) are LOW. If sensor 2 is not connected, then all specifications for monitoring circuit 2 can be ignored.

If the control unit is being operated with only one sensor (monitoring circuit 2 inactive), then it needs to be connected to terminals Y1 and Y2. Terminals Y3 and Y4 for sensor 2 remain unconfigured.

Sensor activated

If sensor 1 is activated, then the OSSDs from monitoring circuit 1 are in OFF state, signal output M1 is HIGH. The yellow LED “S1” is lit up. If sensor 2 is activated, then the OSSDs from monitoring circuit 2 are in OFF state, signal output M2 is HIGH. The yellow LED “S2” is lit up. If sensor 1 and sensor 2 are activated, then the OSSDs from monitoring circuit 1 and monitoring circuit 2 are in OFF state, signal outputs M1 and M2 are HIGH. The yellow LEDs “S1” and “S2” are lit up.

Sensor cable break

If there is a cable break between sensor 1 and the control unit, all OSSDs from monitoring circuit 1 and 2 are in OFF state, signal outputs M1 and M2 are HIGH. The yellow LED “S1” and the red LED “F” are flashing.

If there is a cable break between sensor 2 and the control unit, all OSSDs from monitoring circuit 1 and 2 are in OFF state, signal outputs M1 and M2 are HIGH. The yellow LED “S1” and the red LED “F” are flashing.

**Terminology: ON state,
OFF state according to
ISO 13856**

If a functioning sensor is connected again after a cable break, the device remains in fault mode. The respective yellow LED "S1" or "S2" and the red LED "F" continue flashing, the OSSDs of both monitoring circuits remain in OFF state and the signal outputs at HIGH. An interruption of at least 500 ms to the supply voltage will reset the fault mode. A detected cable break which is not fixed on monitoring circuit 2 is no longer registered after restarting the control unit (supply voltage interruption of < 500 ms). Monitoring circuit 2 becomes inactive and its OSSDs remain in OFF state. The control unit is now in the mode: Monitoring circuit 2 inactive.

Reset

Automatic reset

The control unit operates without a reset function. If the pressure-sensitive protection device is no longer actuated, the output signal switching device of the control unit automatically changes from the OFF state to the ON state. Without additional start interlock, the machine would start up again immediately.

Controlled reset

The control unit operates with a reset function. If the pressure-sensitive protection device is no longer actuated, the output signal switching device of the control unit is in OFF state. This prevents restart of the machine. Only the manual reset command effectuates the change from the OFF state to the ON state.

If the defined signal pulse of the higher-level control is applied to terminal S14, the output signal switching device changes from the OFF to the ON state again with a delay t_w .

A HIGH signal at terminal S15 triggers a reset.

Conditions for the signal pulse of the higher-ranking control system:

- Signal duration min. / max. 60 ms / 13 s
- Signal voltage min. / max. 10 V / 24 V

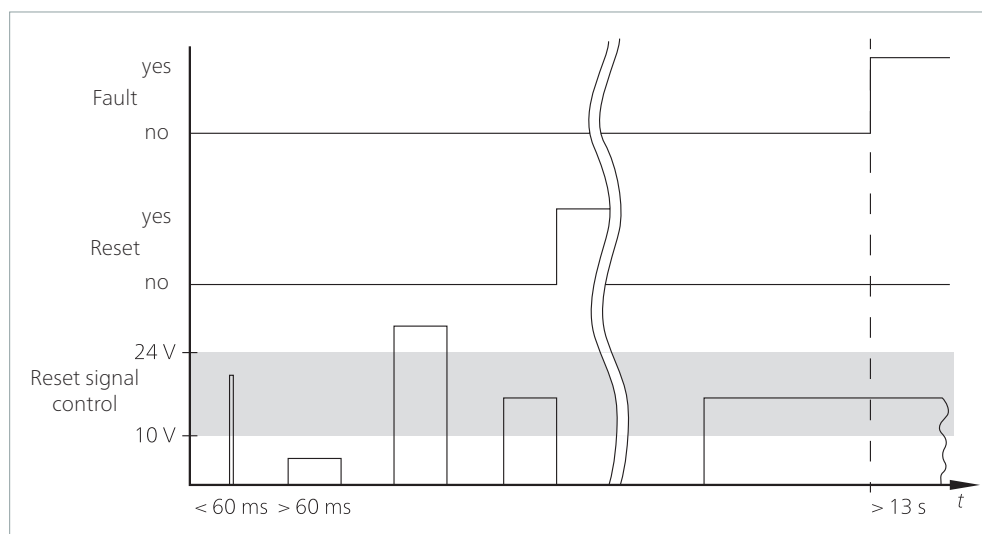

No reset will take place if the signal pulse min. is not reached or the pulse voltage is not maintained.

If the signal pulse max. is exceeded, the control unit changes to the mode: "Fault / System error" (see Chapter *Troubleshooting and remedies*).

Manual reset

The control unit operates with a reset function. If the pressure-sensitive protection device is no longer actuated, the output signal switching device of the control unit is in OFF state. This prevents restart of the machine. Only the manual reset command effectuates the change from the OFF state to the ON state.

If the reset button is pressed, the OSSDs return to the ON state again with a delay t_w . The control unit monitors the reset button and detects a malfunction via the actuation period. The conditions for this are:

- Signal duration min. / max. 60 ms / 13 s

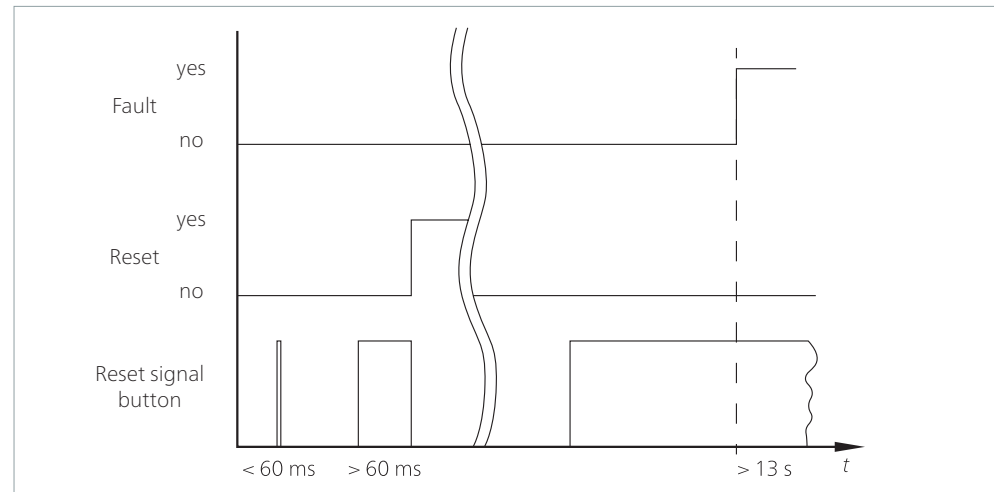

If the actuation period is not reached, then reset will not take place.

If the actuation period max. is exceeded, the control unit changes to the mode: "Fault / System error" (see Chapter *Troubleshooting and remedies*).

Installation

For your safety, the well-known safety rules also apply for assembly:

- Disconnect all devices and live parts in the immediate vicinity from the power supply.
- Ensure that all devices and live parts cannot be switched back on.
- Test to ensure that all devices and live parts are disconnected from the power supply.

1. Mount the control unit in any position on a 35 mm mounting rail type IEC 60715.

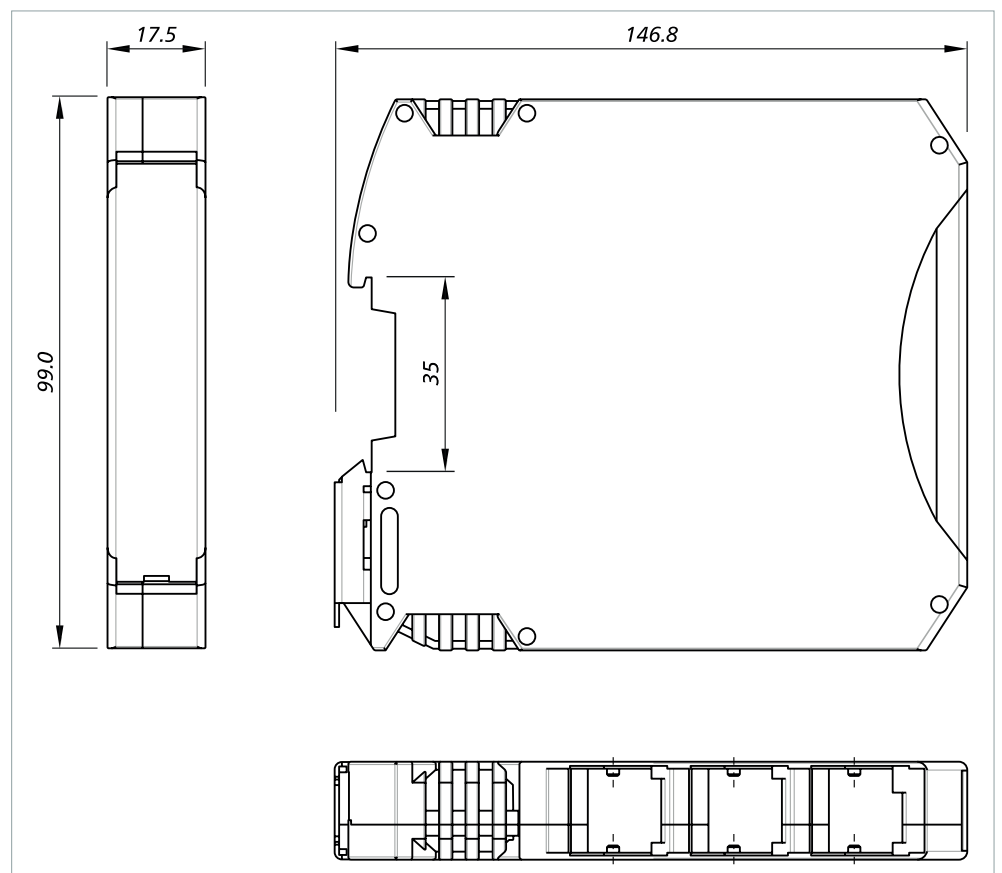

⚠ Caution: Functional impairment due to overheating

If the control unit is overheated due to the effects of external heat, this can result in functional impairment or failure of the pressure-sensitive protection device.

➔ Always ensure sufficient distance from heat sources (at least 2 cm).

2. Wire the sensors, semiconductor outputs and supply voltage to the cable terminals

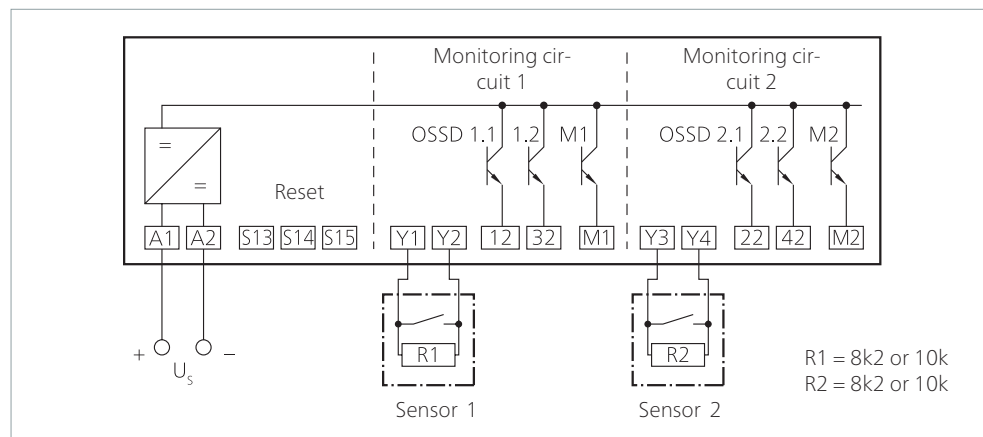

The OSSDs 1.1, 1.2, 2.1 and 2.2 are semiconductor outputs (PNP) and short-circuit-proof. In the HIGH state (ON state) the voltage $U_s - 3\%$ tolerance is applied, depending on the voltage load and supply voltage.

This applies for the outputs:

- ➔ Wire the load between the output terminal and A2.

Reset

Automatic reset

Bridges must be set for an automatic reset (without reset function).

- ➔ Place the bridges between cable terminals S13 and S15 and also between S14 and S15.

The reset (with reset function) can be set up using a higher-level control (or a push-button):

Controlled reset

- ➔ Wire the control output to cable terminal S14.

Terminals S13 and S15 remain unconfigured.

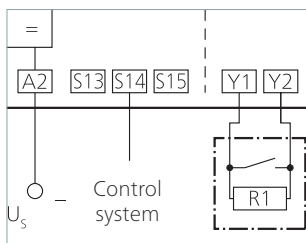
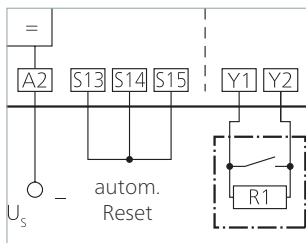

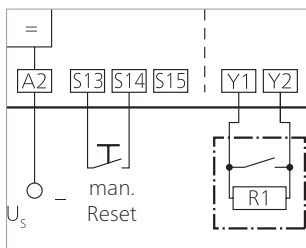

Manual reset

➔ Wire up a button between cable terminals S13 and S14.

Terminal S15 remains unconfigured.

Signal outputs

The signal outputs M1 (sensor 1) and M2 (sensor 2) are semiconductor outputs (PNP) and short-circuit-proof. In the HIGH state, the voltage $U_s - 3\%$ tolerance is applied, depending on the voltage load and supply voltage.

This applies for signal outputs:

➔ Wire the load between the output terminal and A2.

NOTE

In an electromagnetic extreme case (surge pulse) the signal outputs may flicker. This does not affect the safety function.

➔ Protect the control unit from excessive EMC radiation.

Connection examples

Connection examples 1

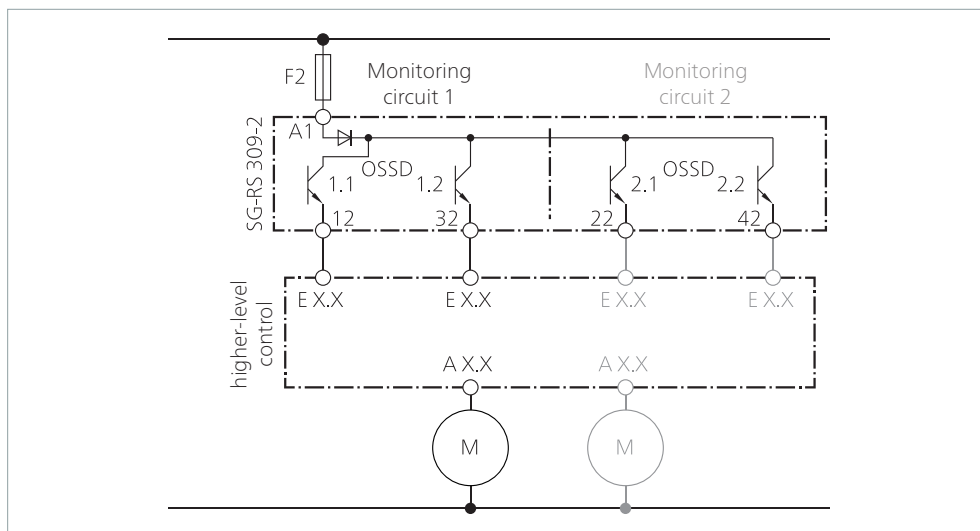

Connection examples 2

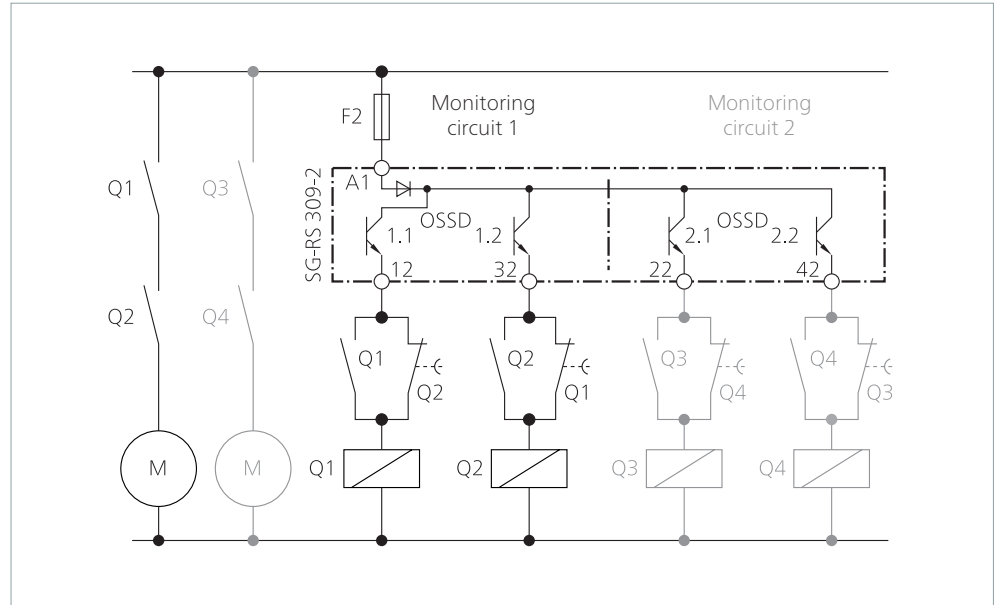

Manual reset

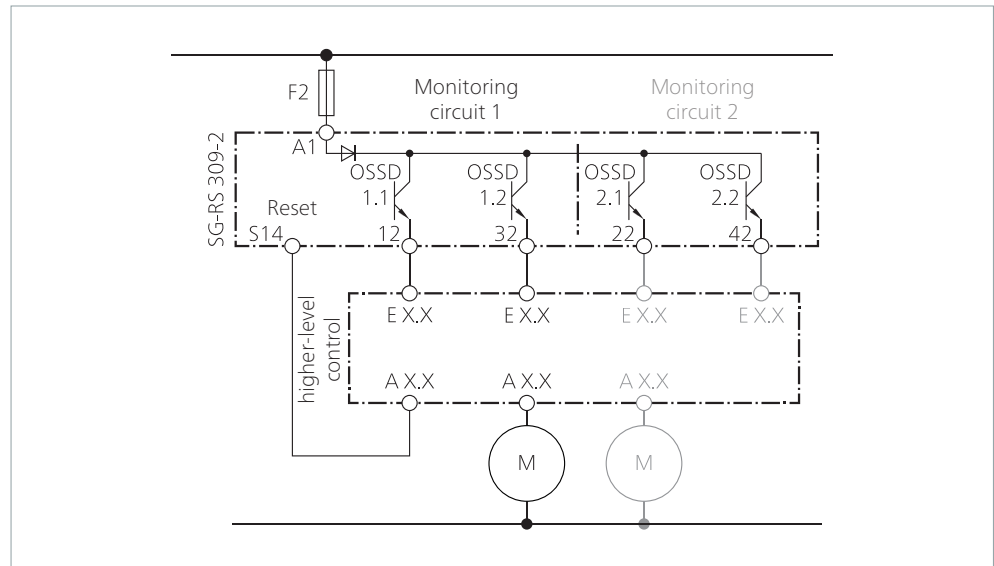

Contact duplication

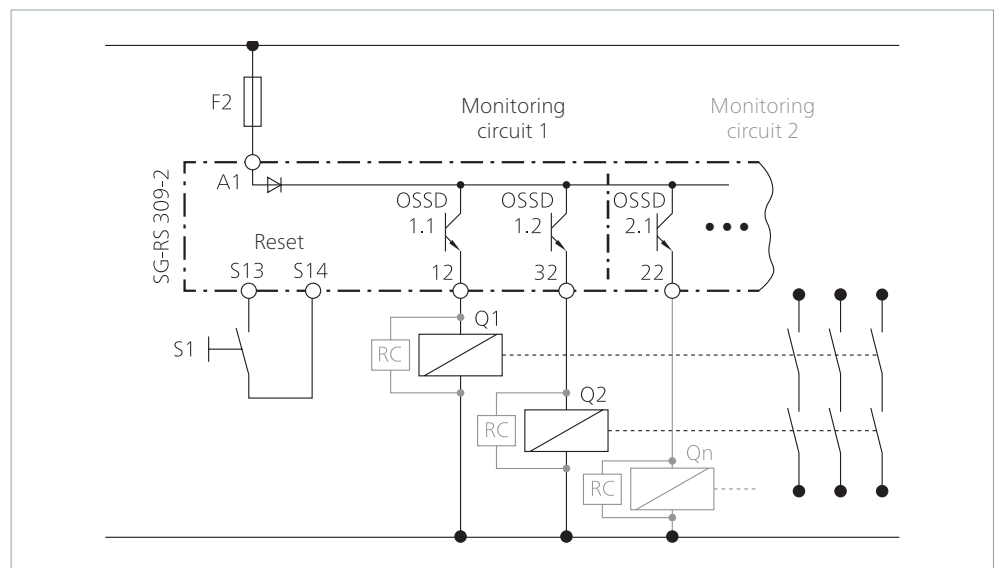

Commissioning

1. Make sure the plug connections are firmly attached.
2. Connect the supply voltage.

⚠ WARNING: Danger of injury due to electrocution
➔ Never unplug plug connections with the power on.

Testing

Automatic reset

1. Make sure that everything is connected and no sensor is activated.
 - green LED "P" is lit
 - OSSDs from monitoring circuit 1 and monitoring circuit 2 in ON state
 - signal outputs M1 and M2 at LOW
2. Actuate sensor 1.
 - yellow LED "S1" is lit
 - OSSDs from monitoring circuit 1 in OFF state
 - signal output M1 at HIGH
3. Repeat step 1.
4. If connected, activate sensor 2.
 - yellow LED "S2" is lit
 - OSSDs from monitoring circuit 2 in OFF state
 - signal output M2 at HIGH
5. Repeat step 1.
6. Disconnect sensor 1.
 - yellow LED "S1" and red LED "F" are flashing
 - OSSDs from monitoring circuit 1 and 2 in OFF state
 - signal outputs M1 and M2 at HIGH
7. Repeat step 1.
8. Disconnect the power supply for at least 500 ms.
 - the control unit will restart

9. If connected, disconnect sensor 2.
 - yellow LED "S2" and red LED "F" are flashing
 - OSSDs from monitoring circuit 1 and 2 in OFF state
 - signal outputs M1 and M2 at HIGH
10. Repeat step 1.
11. Disconnect the power supply for at least 500 ms.
 - the control unit will restart

When the functional test has been successfully completed the pressure-sensitive protection device is ready for operation.

If the functional test was faulty, see chapter *Troubleshooting and remedies*.

Controlled reset and manual reset

1. Make sure that everything is connected and no sensor is activated.
 - green LED "P" and the LEDs "S1" and "S2" are lit
 - OSSDs from monitoring circuit 1 and 2 in OFF state
 - signal outputs M1 and M2 at HIGH
2. Initiate a reset signal by the higher-level control or press the reset button.
 - green LED "P" is lit
 - OSSDs from monitoring circuit 1 and monitoring circuit 2 in ON state
 - signal outputs M1 and M2 at LOW
3. Actuate sensor 1.
 - yellow LED „S1" is lit
 - OSSDs from monitoring circuit 1 in OFF state
 - signal output M1 at HIGH
4. Repeat steps 1 and 2.
5. If connected, activate sensor 2.
 - yellow LED "S2" is lit
 - OSSDs from monitoring circuit 2 in OFF state
 - signal output M2 at HIGH
6. Repeat steps 1 and 2.
7. Disconnect sensor 1.
 - yellow LED "S1" and red LED "F" are flashing
 - OSSDs from monitoring circuit 1 and 2 in OFF state
 - signal outputs M1 and M2 at HIGH
8. Repeat step 1.

9. Disconnect the power supply for at least 500 ms.
 - the control unit will restart
10. Repeat step 2.
11. If connected, disconnect sensor 2.
 - yellow LED "S2" and red LED "F" are flashing
 - OSSDs from monitoring circuit 1 and 2 in OFF state
 - signal outputs M1 and M2 at HIGH
12. Repeat step 1.
13. Disconnect the power supply for at least 500 ms.
 - the control unit will restart
14. Repeat step 2.

When the functional test has been successfully completed the pressure-sensitive protection device is ready for operation.

If the functional test was faulty, see chapter *Troubleshooting and remedies*.

Pressure-sensitive protection device actuated

As long as the pressure-sensitive protection device remains actuated, the output signal switching devices of the control unit remain in the safe OFF state.

If actuation of the pressure-sensitive protection device ends, different states are possible on the output signal switching devices of the control unit. This depends on the selected reset type (see chapter *Operation*, subchapter *Reset*).

Correlations

LEDs				Outputs				Meaning
"P" green	"S1" yellow	"S2" yellow ¹⁾	"F" red	1.1, 1.2	2.1, 2.2 ¹⁾	M1	M2 ¹⁾	LED off: ○ LED on: ● LED flashing: ⊙
○	○	○	○	OFF state	OFF state	LOW	LOW	Supply voltage off
●	○	○	○	ON state	ON state	LOW	LOW	Control unit ready
●	●	○	○	OFF state	ON state	HIGH	LOW	Sensor 1 actuated
●	○	●	○	ON state	OFF state	LOW	HIGH	Sensor 2 actuated
●	⊙	○	⊙	OFF state	OFF state	HIGH	HIGH	Fault at sensor 1 (cable break)
●	○	⊙	⊙	OFF state	OFF state	HIGH	HIGH	Fault at sensor 2 (cable break)
●	●	●	⊙	OFF state	OFF state	HIGH	HIGH	Fault / Systemerror
●	●	●	⊙	OFF-/ON-state	OFF state	HIGH	HIGH	Fault monitoring circuit 1; OSSD 1.1: OFF state and 1.2: ON state or OSSD 1.1: ON state and 1.2: OFF state
●	●	●	⊙	OFF state	OFF-/ON-state	HIGH	HIGH	Fault monitoring circuit 2; OSSD 2.1: OFF state and 2.2: ON state or OSSD 2.1: ON state and 2.2: OFF state

¹⁾ Only applies if sensor 2 is connected.

Decommissioning

- ➔ Switch off the pressure-sensitive protection device and safeguard it from being switched back on unintentionally.
- ➔ Affix a clear warning on the pressure-sensitive protection device warning that states it is temporarily or definitively decommissioned.

Recommissioning

- ➔ Carry out commissioning (see chapter *Commissioning*).

Maintenance and cleaning

Maintenance

The control unit is maintenance-free.

- ➔ Repeat the operational test monthly.

Cleaning

- ➔ Clean the outside of the enclosure with a dry cloth.

Troubleshooting and remedies

Prerequisite: the control unit is connected to the supply voltage and sensor. No sensor is activated.

Fault display	Possible cause	Elimination
green LED "P" not lit up	No or incorrect supply voltage	<ol style="list-style-type: none"> 1. Check supply voltage, compare with type plate 2. Check terminal connections
	If supply voltage is correctly connected: control unit is faulty	➔ Replace control unit
yellow LED "S1" is lit	Sensor 1 is faulty	<ol style="list-style-type: none"> 1. Measure resistance at sensor 1: Set value = $8k2 \pm 5 \%$ or $10k \pm 5 \%$ 2. Actual value \neq set value: Sensor faulty 3. Replace sensor
	Control unit is faulty	<ol style="list-style-type: none"> 1. Connect 8k2 or 10k resistor to terminals Y1, Y2 2. Fault not remedied: Replace control unit
yellow LED "S2" is lit	Sensor 2 is faulty	<ol style="list-style-type: none"> 1. Measure resistance at sensor 2: Set value = $8k2 \pm 5 \%$ or $10k \pm 5 \%$ 2. Actual value \neq set value: Sensor faulty 3. Replace sensor
	Control unit is faulty	<ol style="list-style-type: none"> 1. Connect 8k2 or 10k resistor to terminals Y3, Y4 2. Fault not remedied: Replace control unit

Fault display	Possible cause	Elimination
yellow LED "S1" and red LED "F" are flashing	Sensor not connected or incorrectly connected to terminal Y1 and Y2	➔ Connect sensor
	Cable break at sensor 1	<ol style="list-style-type: none"> 1. Measure resistance at sensor 1: Set value = $8k2 \pm 5 \%$ or $10k \pm 5 \%$ 2. Actual value > 1M: Sensor faulty 3. Replace sensor 4. Disconnect power supply for at least 500 ms
yellow LED "S2" and red LED "F" are flashing	Sensor not connected or incorrectly connected to terminal Y3 and Y4	➔ Connect sensor
	Cable break at sensor 2	<ol style="list-style-type: none"> 1. Measure resistance at sensor 2: Set value = $8k2 \pm 1 \%$ or $10k \pm 1 \%$ 2. Actual value > 1M: Sensor faulty 3. Replace sensor 4. Disconnect power supply for at least 500 ms
green LED "P", yellow LEDs "S1" and/or "S2" are lit	manual reset: <ul style="list-style-type: none"> - no reset signal from higher-level control or reset button not pressed - signal duration / activation period too short 	➔ Initiate transmission signal from controller or press reset button (≥ 60 ms)
	manual reset: connection to control or to button interrupted	➔ Check connection
	automatic reset: bridges missing	➔ Place bridges between S13 and S15 as well as between S14 and S15
	Control unit is faulty	➔ Replace control unit
green LED "P", yellow LEDs "S1" and "S2" are lit, red LED "F" is flashing	manual reset: duration of transmission signal from higher-level control too long or button jammed	➔ Check the duration of the transmission signal (≤ 13 s) of the higher-level control or replace reset button on S13 and S14
	Control unit is faulty	➔ Replace control unit

The fault can still not be removed?

- ➔ Contact Mayser support: Phone +49 731 2061-0.
- ➔ In case of queries, have the information on the type plate at hand.

Type plate

A type plate for identification of the control unit is affixed on the side.

Replacement parts

⚠ CAUTION Overall safety endangered

If the sensor is not replaced with original Mayser parts, operation of the protective device may be impaired.

➔ Only use original parts from Mayser.

Disposal

Control unit

The devices produced by Mayser are professional electronic tools exclusively intended for commercial use (so-called B2B devices). Unlike devices mainly used in private households (B2C), they may not be disposed of at the collection centres of public sector disposal organisations (e.g. municipal recycling depots). At the end of their useful life, the devices may be returned to us for disposal.

WEEE reg. no. DE 39141253

Packaging

- Wood, cardboard, plastics

➔ Observe the following with respect to disposal:

- Comply with the relevant national disposal regulations and legal stipulations for these materials.
- If you engage a disposal firm, make sure that a list of the above materials is included.
- Materials should be recycled or disposed of in an eco-friendly manner.

Technical data

SG-RS 309-2	DC 24 V to 36 V
Testing basis	EN 45545, EN 50155, ISO 13849-1, ISO 13856-1, ISO 13856-2, ISO 13856-3
Connecting voltage U_s	
Nominal voltage	DC 24 V to 36 V
Voltage tolerance	-30 % to +25 %
Nominal current (outputs unloaded)	18 mA
Current max.	30 mA
EN 50155: Switching class power supply	C2
EN 50155: Interruption class power supply	S2
Power consumption (outputs unloaded)	< 1.5 W
Melting integral (I^2t)	4.5 A ² s
Line length (max.)	10 m
Internal protection	2.5 A slow-acting
Times	
Reaction time t_a	< 15 ms
Start time (max.)	2 s
Re-start time t_w	< 150 ms
Safety classifications	
ISO 13856: Reset function	with/without
ISO 13849-1:2015	Category 3 PL d
MTTF _D	937 a
DC _{avg}	92 %
B _{10D}	–
n _{op} (Estimate)	52560/a
CCF	Requirements fulfilled
Inputs	
Sensor 1 and 2	Y1, Y2 and Y3, Y4
Monitoring resistor	8k2 or 10 kOhm
Tolerance range (max.)	-5 % to +10 %
Switching thresholds	
Sensor activated	< 6 kOhm
Cable break	> 14.6 kOhm
Line resistance	< 10 Ohm
Line length (max.)	30 m
Reset	
Line length (max.)	10 m
Outputs	
Monitoring circuit 1 and 2	12, 32 and 22, 42
EN 60947-5-1: Utilization category	DC-12: 100 mA
Switching voltage (max.)	U_s min. - 0.7 V
Switching voltage (min.)	0 V
Switching current (max.)	100 mA
Switching current (min.)	> 0 mA
Nominal output (max.)	3.6 W
Switching operations, mechanical	–
Line length (max.)	10 m

SG-RS 309-2	DC 24 V to 36 V
Signal output M1 / M2 EN 60947-5-1: Utilization category Switching voltage (max.) Switching voltage (min.) Switching current (max.) Switching current (min.) Switching capacity (max.) Line length (max.)	DC-12: 100 mA U_s min. - 0.7 V 0 V 100 mA > 0 mA 3.6 W 10 m
Mechanical operating conditions	
Cable terminals solid wire strand without sheath strand with sheath without plastic sleeve with plastic sleeve IEC 60529: Degree of protection EN 50124: Soiling degree max. humidity (23 °C) EN 50125: Altitude range class Operating temperature Storage temperature EN 50155: Operating temperature class EN 50155: Temperature change class 2006/42/EG: Emission sound pressure level EN 61373: Shock and vibration Vibration fatigue limit Frequency range Amplitude Cycles per axis Protective coating Dimensions (W × H × D) Weight	6× 4-pin 1× 1.5 mm ² or 2× 0.5 mm ² 1× 1.5 mm ² or 2× 0.75 mm ² 1× 1.5 mm ² or 2× 0.34 mm ² 1× 0.5 mm ² or TWIN 0.5 mm ² IP20 PD 2 95 % A1 -25 to +70 °C -25 to +70 °C OT3 H1 < 70 dB(A) Category 1 Class B 10 to 55 Hz 0.15 mm 10 yes 17.5 × 99 × 114.5 mm 115 g